



LIFTING & SAFETY  
**PRICE LIST**





## Welcome

Starke delivers innovation, quality, and efficiency to manufacturers across North America. With trusted manufacturing partners in Japan, Taiwan, China, and the USA, we offer high-performance hoists and rigging equipment at fair prices.

Starke products are precision-engineered, rigorously tested, and built to exceed industry standards. Our focus on innovation means advanced controls, ergonomic designs, and reliable performance that minimizes downtime and maximizes productivity.

We're built for the crane builder, safety provider, and end-user — understanding that you can't afford to wait months for equipment. That's why we partner with distributors who stock our products, ready for quick delivery.

When you choose Starke, you're investing in equipment that keeps your operations moving. Contact your distributor today — chances are, what you need is already on the shelf.

*Starke America Team*

# Table of Contents

## Hoists



### Electric Chain Hoists

STK Series	p. 6-7
Corrosion Resistant	p. 10
STK-VS Series	p. 12-13
SSP Series	p. 16
Blitz Series (3 Phase)	p. 18
Blitz VS Series	p. 20
Blitz Smart Series	p. 22
Work Shop Series	p. 24
Blitz (Single Phase)	p. 26



### Trolleys

Manual Trolleys	p. 28-29
Motorized Trolleys	p. 30
Corrosion Resistant	p. 32
SST Series	p. 34
Tractor Drives	p. 36



### Chain Hoist Upgrades

Load Chain	p. 37
Pendants & Cable	p. 37
Chain Containers	p. 38
Weather Covers	p. 38



### Wire Rope Hoists

Amp Draw Chart	p. 39
SMW Series	p. 40-42
STW Series	p. 44-48

## Crane Components



### End Trucks

Top-Running	p. 53
Top Runner	p. 58
Under-Running	p. 60
Crane Bumpers	p. 63
Manual End Trucks	p. 64



### Enclosed Track

Track	p. 66
Components	p. 67

## Electrification & Controls



### Electrification

ElectroTrack	p. 68-69
FlexTrack	p. 70
Festoon System	p. 71

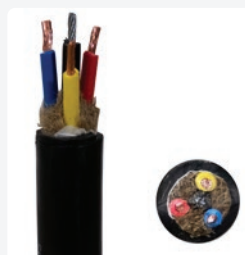

### Controls

Power, Control, Pendant Cable, & Plugs	p. 72-73
VFD Control Panels	p. 74-75
Radio Control Kits	p. 76-79
Collision Avoidance Kits	p. 80-81

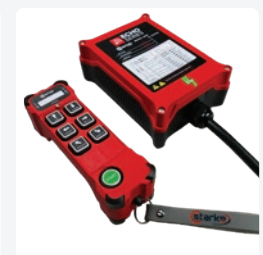

## Crane Kits



**Top-Running**  
p. 82

This block shows the components for a top-running crane kit. It includes a 3-ton motorized hoist, a control panel, a crane beam, and a yellow top runner assembly.



**Top Runner**  
p. 102

This block shows the components for a top runner crane kit. It includes a motorized hoist with a hook, a control panel, and a yellow top runner assembly.



**Under-Running**  
p. 110

This block shows the components for an under-running crane kit. It includes a 5-ton motorized hoist, a control panel, a crane beam, and a yellow under-running assembly.

## Slings



**Chain Slings**  
Grade 80 p. 122  
Grade 100 p. 123

This block features two blue chain slings with hooks at both ends, one in a V-shape and one in a U-shape.



**Web Slings** p. 125

This block shows a yellow web sling with a blue hook at one end and a loop at the other.

## Safety



**Safety Harnesses**  
Basic & Deluxe p. 126

This block shows a person wearing a safety harness and a separate orange and black safety harness.



**SRLs & Lanyards**  
p. 128

This block shows a Self-Retracting Lanyard (SRL) and a yellow lanyard with a hook.



**Fall Arrest Trolleys**  
p. 129

This block shows a red fall arrest trolley with a hook and a label.



**Secondary Brake Devices**  
p. 130-131

This block shows a blue secondary brake device with a handle and a label.

# HOISTS ELECTRIC CHAIN HOISTS

## STK Series

Single Speed Electric Chain Hoist  
(½ Ton – 2 Ton)



### How to Order

Please designate letter for trolley options at the end of the SKU.

#### Examples:

STK0526-10-460V-3PH-**A** (Rigid Top Hook)

STK1026-10-460V-3PH-**B** (SPT Lug Trolley)

STK5011-20-230V-3PH-**C** (Motorized VS Trolley)

CRANE COMPONENTS

ELECTRIFICATION & CONTROLS

CRANE KITS

SLINGS

SAFETY

SKU	Cap	Speed	Lift	Reeving	Voltage	HP	Amp	Headroom	Net Weight	List Price Options		
										A	B	C
										Rigid Top Hook	SPT Lug Trolley	Motorized VS Trolley
STK0526-10-460V-3PH	½ Ton	26 FPM	10'	Single	460/3	1	1.9	20"	95 lbs	\$2,469	\$2,718	\$5,478
STK0526-10-230V-3PH	½ Ton	26 FPM	10'	Single	208-230/3	1	3.8	20"	95 lbs	\$2,569	\$2,818	\$5,778
STK0526-15-460V-3PH	½ Ton	26 FPM	15'	Single	460/3	1	1.9	20"	98 lbs	\$2,578	\$2,827	\$5,587
STK0526-15-230V-3PH	½ Ton	26 FPM	15'	Single	208-230/3	1	3.8	20"	98 lbs	\$2,678	\$2,927	\$5,887
STK0526-20-460V-3PH	½ Ton	26 FPM	20'	Single	460/3	1	1.9	20"	101 lbs	\$2,688	\$2,937	\$5,697
STK0526-20-230V-3PH	½ Ton	26 FPM	20'	Single	208-230/3	1	3.8	20"	101 lbs	\$2,788	\$3,037	\$5,997
STK1026-10-460V-3PH	1 Ton	26 FPM	10'	Single	460/3	2	3.9	23"	130 lbs	\$3,397	\$3,699	\$6,406
STK1026-10-230V-3PH	1 Ton	26 FPM	10'	Single	208-230/3	2	7.8	23"	130 lbs	\$3,497	\$3,799	\$6,706
STK1026-15-460V-3PH	1 Ton	26 FPM	15'	Single	460/3	2	3.9	23"	134 lbs	\$3,522	\$3,824	\$6,531
STK1026-15-230V-3PH	1 Ton	26 FPM	15'	Single	208-230/3	2	7.8	23"	134 lbs	\$3,622	\$3,924	\$6,831
STK1026-20-460V-3PH	1 Ton	26 FPM	20'	Single	460/3	2	3.9	23"	138 lbs	\$3,655	\$3,957	\$6,664
STK1026-20-230V-3PH	1 Ton	26 FPM	20'	Single	208-230/3	2	7.8	23"	138 lbs	\$3,755	\$4,057	\$6,964
STK2026-10-460V-3PH	2 Ton	26 FPM	10'	Single	460/3	4	7.8	28"	241 lbs	\$4,325	\$4,826	\$7,851
STK2026-10-230V-3PH	2 Ton	26 FPM	10'	Single	208-230/3	4	15.6	28"	241 lbs	\$4,425	\$4,926	\$8,151
STK2026-15-460V-3PH	2 Ton	26 FPM	15'	Single	460/3	4	7.8	28"	248 lbs	\$4,510	\$5,011	\$8,036
STK2026-15-230V-3PH	2 Ton	26 FPM	15'	Single	208-230/3	4	15.6	28"	248 lbs	\$4,610	\$5,111	\$8,336
STK2026-20-460V-3PH	2 Ton	26 FPM	20'	Single	460/3	4	7.8	28"	255 lbs	\$4,697	\$5,198	\$8,223
STK2026-20-230V-3PH	2 Ton	26 FPM	20'	Single	208-230/3	4	15.6	28"	255 lbs	\$4,797	\$5,298	\$8,523

\* For Starke SPT Lug Trolley information, go to page 29.

\*\* For Starke Motorized VS Trolleys information, go to page 30.

# STK Series

## Single Speed Electric Chain Hoist

(3 Ton – 5 Ton)



### How to Order

Please designate letter for trolley options at the end of the SKU.

#### Examples:

STK0526-10-460V-3PH-**A** (Rigid Top Hook)

STK1026-10-460V-3PH-**B** (SPT Lug Trolley)

STK5011-20-230V-3PH-**C** (Motorized VS Trolley)

SKU	Cap	Speed	Lift	Reeving	Voltage	HP	Amp	Headroom	Net Weight	List Price Options		
										A	B	C
										Rigid Top Hook	SPT Lug Trolley	Motorized VS Trolley
STK3021-10-460V-3PH	3 Ton	21 FPM	10'	Single	460/3	4	7.8	32"	244 lbs	\$6,002	N/A	\$9,712
STK3021-10-230V-3PH	3 Ton	21 FPM	10'	Single	208-230/3	4	15.6	32"	244 lbs	\$6,102	N/A	\$10,012
STK3021-15-460V-3PH	3 Ton	21 FPM	15'	Single	460/3	4	7.8	32"	253 lbs	\$6,227	N/A	\$9,937
STK3021-15-230V-3PH	3 Ton	21 FPM	15'	Single	208-230/3	4	15.6	32"	253 lbs	\$6,327	N/A	\$10,237
STK3021-20-460V-3PH	3 Ton	21 FPM	20'	Single	460/3	4	7.8	32"	262 lbs	\$6,452	N/A	\$10,162
STK3021-20-230V-3PH	3 Ton	21 FPM	20'	Single	208-230/3	4	15.6	32"	262 lbs	\$6,552	N/A	\$10,462
STK5011-10-460V-3PH	5 Ton	11 FPM	10'	Double	460/3	4	7.8	37"	306 lbs	\$6,502	N/A	\$10,675
STK5011-10-230V-3PH	5 Ton	11 FPM	10'	Double	208-230/3	4	15.6	37"	306 lbs	\$6,602	N/A	\$10,975
STK5011-15-460V-3PH	5 Ton	11 FPM	15'	Double	460/3	4	7.8	37"	315 lbs	\$6,889	N/A	\$11,062
STK5011-15-230V-3PH	5 Ton	11 FPM	15'	Double	208-230/3	4	15.6	37"	315 lbs	\$6,989	N/A	\$11,362
STK5011-20-460V-3PH	5 Ton	11 FPM	20'	Double	460/3	4	7.8	37"	324 lbs	\$7,277	N/A	\$11,450
STK5011-20-230V-3PH	5 Ton	11 FPM	20'	Double	208-230/3	4	15.6	37"	324 lbs	\$7,377	N/A	\$11,750

\* For Starke SPT Lug Trolley information, go to page 29.

\*\* For Starke Motorized VS Trolleys information, go to page 30.

## Features of STK Series

- 460V, 230V, 208V - 3 Phase capable
- Fast lifting and lower speed at 26 FPM
- Canvas Chain Container
- Includes quick plug in pendant cable
- Remove pendant and quick plug in radio receiver for (optional) radio control
- Efficient and reliable lifting motor & brake assembly



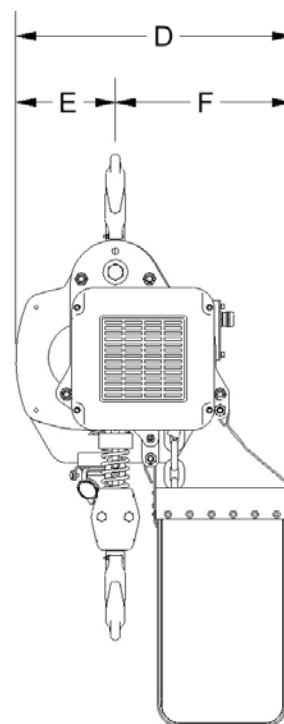
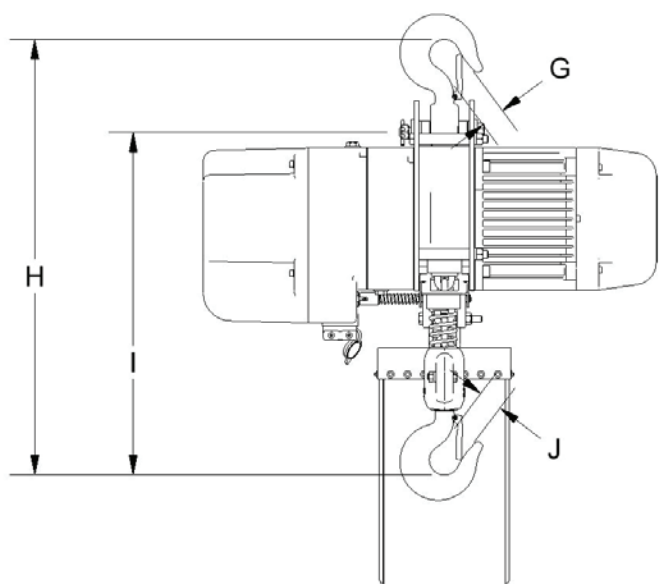
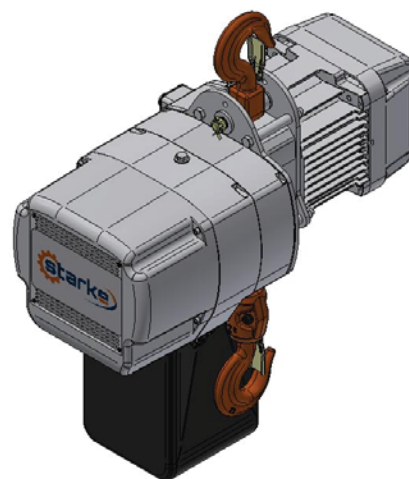
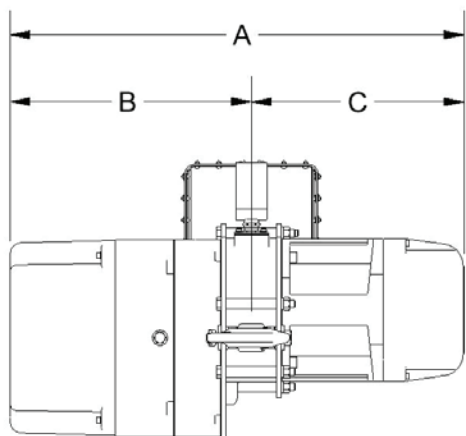

	STK Series Dimensions								Headroom Dimensions	
	A	B	C	D	E	F	G	J	(I) Lug Pin	(H) Standard
STK0526	22 3/8"	11 7/8"	10 1/2"	12 1/2"	4 3/8"	8 1/8"	1 1/16"	1 1/16"	12 3/8"	19"
STK1026	24 5/8"	12 13/16"	11 13/16"	12 1/8"	4 15/16"	7 3/16"	1 1/4"	1 1/4"	18 5/8"	22 3/8"
STK2026	28 13/16"	15 5/16"	13 1/2"	17 9/16"	6 5/16"	11 1/4"	1 1/2"	1 1/2"	20 1/8"	26 1/8"
STK3021	28 15/16"	15 7/16"	13 1/2"	16 5/16"	6 3/8"	9 15/16"	1 3/4"	1 3/4"	21 13/16"	28 7/8"
STK5011	28 15/16"	15 9/16"	13 3/8"	16 5/16"	4 1/16"	12 1/4"	1 7/8"	1 7/8"	27"	35 7/8"

# STK - CR Series

## Corrosion Resistant Electric Chain Hoist



 **Special Anti-Rust & Anti-Corrosion Epoxy Paint**

 **Corrosion-Resistant Plated Load Chain**

 **304 Stainless Steel Chain Container**

 **Corrosion-Resistant Upper and Lower Hook**

 To ensure longevity, we recommend also purchasing a Canvas Hoist Weather Cover on page 38



SKU	Cap	Speed	Lift	Reeving	Voltage	HP	Amp	Headroom	Net Weight	Rigid Top Hook
STK0526-20-460V-CR	½ Ton	26 FPM	20'	Single	460/3	1	1.9	20"	101 lbs	\$3,528
STK1026-20-460V-CR	1 Ton	26 FPM	20'	Single	460/3	2	3.9	23"	138 lbs	\$4,262
STK2026-20-460V-CR	2 Ton	26 FPM	20'	Single	460/3	4	7.8	28"	255 lbs	\$6,657
STK3021-20-460V-CR	3 Ton	21 FPM	20'	Single	460/3	4	7.8	32"	262 lbs	\$7,904
STK5011-20-460V-CR	5 Ton	11 FPM	20'	Single	460/3	4	7.8	37"	324 lbs	\$10,665
STK0526-20-230V-CR	½ Ton	26 FPM	20'	Single	230/3	1	3.8	20"	101 lbs	\$3,528
STK1026-20-230V-CR	1 Ton	26 FPM	20'	Single	230/3	2	7.8	23"	138 lbs	\$4,262
STK2026-20-230V-CR	2 Ton	26 FPM	20'	Single	230/3	4	15.6	28"	255 lbs	\$6,657
STK3021-20-230V-CR	3 Ton	21 FPM	20'	Single	230/3	4	15.6	32"	262 lbs	\$7,904
STK5011-20-230V-CR	5 Ton	11 FPM	20'	Single	230/3	4	15.6	37"	324 lbs	\$10,665

- **For Food Grade Applications:** our corrosion-resistant units **do not** come with food grade oil and grease
- NEMA 3X Rated

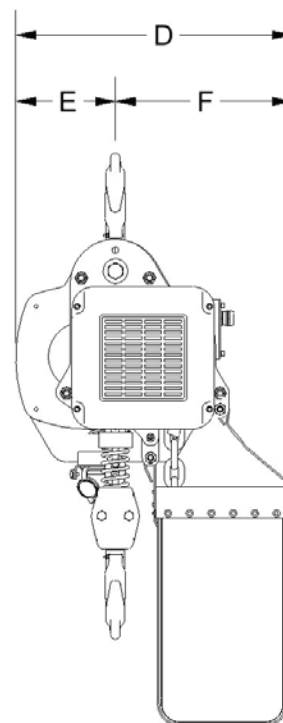
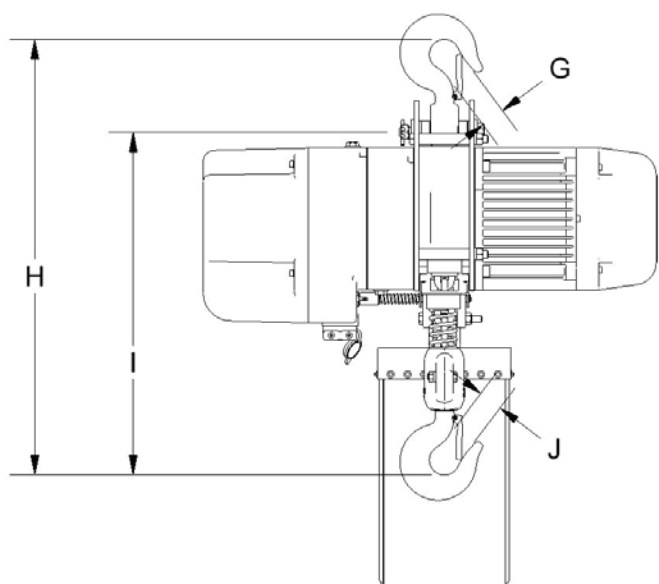
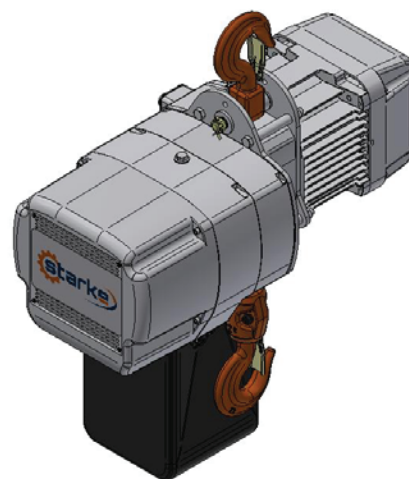
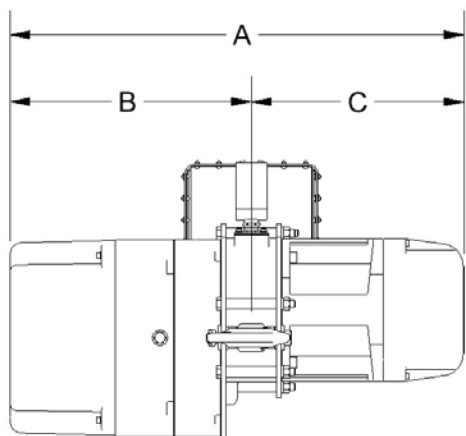

	STK Series Dimensions								Headroom Dimensions	
	A	B	C	D	E	F	G	J	(I) Lug Pin	(H) Standard
STK0526	22 3/8"	11 7/8"	10 1/2"	12 1/2"	4 3/8"	8 1/8"	1 1/16"	1 1/16"	12 3/8"	19"
STK1026	24 5/8"	12 13/16"	11 13/16"	12 1/8"	4 15/16"	7 3/16"	1 1/4"	1 1/4"	18 5/8"	22 3/8"
STK2026	28 13/16"	15 5/16"	13 1/2"	17 9/16"	6 5/16"	11 1/4"	1 1/2"	1 1/2"	20 1/8"	26 1/8"
STK3021	28 15/16"	15 7/16"	13 1/2"	16 5/16"	6 3/8"	9 15/16"	1 3/4"	1 3/4"	21 13/16"	28 7/8"
STK5011	28 15/16"	15 9/16"	13 3/8"	16 5/16"	4 1/16"	12 1/4"	1 7/8"	1 7/8"	27"	35 7/8"



## STK-VS Series

### Variable Speed Electric Chain Hoist

(½ Ton – 1 Ton)

#### How to Order

Please designate letter for trolley options at the end of the SKU.

#### Examples:

STK05VS-10-460V-**A** (Rigid Top Hook)

STK10VS-10-230V-3PH-**B** (SPT Lug Trolley)

STK30VS-20-230V-3PH-**C** (Motorized VS Trolley)



SKU	Cap	Adjustable Speed	Lift	Reeving	Voltage	HP	Amp	Headroom	Net Weight	List Price Options		
										A Rigid Top Hook	B SPT Lug Trolley	C Motorized VS Trolley
STK05VS-10-460V-3PH	½ Ton	2 - 26 FPM	10'	Single	460/3	1	1.9	20"	102 lbs	\$3,187	\$3,436	\$6,196
STK05VS-10-230V-3PH	½ Ton	2 - 26 FPM	10'	Single	208-230/3	1	3.8	20"	102 lbs	\$3,387	\$3,636	\$6,596
STK05VS-10-230V-1PH	½ Ton	2 - 26 FPM	10'	Single	230/1	1	7.6	20"	102 lbs	\$3,687	\$3,936	\$6,996
STK05VS-15-460V-3PH	½ Ton	2 - 26 FPM	15'	Single	460/3	1	1.9	20"	105 lbs	\$3,279	\$3,528	\$6,288
STK05VS-15-230V-3PH	½ Ton	2 - 26 FPM	15'	Single	208-230/3	1	3.8	20"	105 lbs	\$3,479	\$3,728	\$6,688
STK05VS-15-230V-1PH	½ Ton	2 - 26 FPM	15'	Single	230/1	1	7.6	20"	105 lbs	\$3,779	\$4,028	\$7,088
STK05VS-20-460V-3PH	½ Ton	2 - 26 FPM	20'	Single	460/3	1	1.9	20"	108 lbs	\$3,371	\$3,620	\$6,380
STK05VS-20-230V-3PH	½ Ton	2 - 26 FPM	20'	Single	208-230/3	1	3.8	20"	108 lbs	\$3,571	\$3,820	\$6,780
STK05VS-20-230V-1PH	½ Ton	2 - 26 FPM	20'	Single	230/1	1	7.6	20"	108 lbs	\$3,871	\$4,120	\$7,180
STK10VS-10-460V-3PH	1 Ton	2 - 26 FPM	10'	Single	460/3	2	3.9	23"	138 lbs	\$4,107	\$4,327	\$7,116
STK10VS-10-230V-3PH	1 Ton	2 - 26 FPM	10'	Single	208-230/3	2	7.8	23"	138 lbs	\$4,307	\$4,527	\$7,516
STK10VS-10-230V-1PH	1 Ton	2 - 26 FPM	10'	Single	230/1	2	15.6	23"	138 lbs	\$4,607	\$4,827	\$7,916
STK10VS-15-460V-3PH	1 Ton	2 - 26 FPM	15'	Single	460/3	2	3.9	23"	142 lbs	\$4,203	\$4,423	\$7,212
STK10VS-15-230V-3PH	1 Ton	2 - 26 FPM	15'	Single	208-230/3	2	7.8	23"	142 lbs	\$4,403	\$4,623	\$7,612
STK10VS-15-230V-1PH	1 Ton	2 - 26 FPM	15'	Single	230/1	2	15.6	23"	142 lbs	\$4,703	\$4,923	\$8,012
STK10VS-20-460V-3PH	1 Ton	2 - 26 FPM	20'	Single	460/3	2	3.9	23"	146 lbs	\$4,301	\$4,521	\$7,310
STK10VS-20-230V-3PH	1 Ton	2 - 26 FPM	20'	Single	208-230/3	2	7.8	23"	146 lbs	\$4,501	\$4,721	\$7,710
STK10VS-20-230V-1PH	1 Ton	2 - 26 FPM	20'	Single	230/1	2	15.6	23"	146 lbs	\$4,801	\$5,021	\$8,110

\* For Starke SPT Lug Trolley information, go to page 29.

\*\* For Starke Motorized VS Trolleys information, go to page 30.



## STK-VS Series Variable Speed Electric Chain Hoist (2 Ton – 3 Ton)

### How to Order

Please designate letter for trolley options at the end of the SKU.

#### Examples:

STK05VS-10-460V-**A** (Rigid Top Hook)

STK10VS-10-230V-3PH-**B** (SPT Lug Trolley)

STK30VS-20-230V-3PH-**C** (Motorized VS Trolley)



SKU	Cap	Adjustable Speed	Lift	Reeving	Voltage	HP	Amp	Headroom	Net Weight	List Price Options		
										A	B	C
										Rigid Top Hook	SPT Lug Trolley	Motorized VS Trolley
STK20VS-10-460V-3PH	<b>2 Ton</b>	2 - 26 FPM	10'	Single	460/3	4	7.8	28"	252 lbs	\$4,956	\$5,236	\$8,482
STK20VS-10-230V-3PH	<b>2 Ton</b>	2 - 26 FPM	10'	Single	208-230/3	4	15.6	28"	252 lbs	\$5,156	\$5,436	\$8,882
STK20VS-15-460V-3PH	<b>2 Ton</b>	2 - 26 FPM	15'	Single	460/3	4	7.8	28"	259 lbs	\$5,843	\$6,123	\$9,369
STK20VS-15-230V-3PH	<b>2 Ton</b>	2 - 26 FPM	15'	Single	208-230/3	4	15.6	28"	259 lbs	\$6,043	\$6,323	\$9,769
STK20VS-20-460V-3PH	<b>2 Ton</b>	2 - 26 FPM	20'	Single	460/3	4	7.8	28"	266 lbs	\$6,100	\$6,380	\$9,626
STK20VS-20-230V-3PH	<b>2 Ton</b>	2 - 26 FPM	20'	Single	208-230/3	4	15.6	28"	266 lbs	\$6,300	\$6,580	\$10,026
STK30VS-10-460V-3PH	<b>3 Ton</b>	2 - 21 FPM	10'	Single	460/3	4	7.8	28"	258 lbs	\$5,617	N/A	\$9,327
STK30VS-10-230V-3PH	<b>3 Ton</b>	2 - 21 FPM	10'	Single	208-230/3	4	15.6	28"	258 lbs	\$5,817	N/A	\$9,727
STK30VS-15-460V-3PH	<b>3 Ton</b>	2 - 21 FPM	15'	Single	460/3	4	7.8	28"	267 lbs	\$6,558	N/A	\$10,268
STK30VS-15-230V-3PH	<b>3 Ton</b>	2 - 21 FPM	15'	Single	208-230/3	4	15.6	28"	267 lbs	\$6,758	N/A	\$10,668
STK30VS-20-460V-3PH	<b>3 Ton</b>	2 - 21 FPM	20'	Single	460/3	4	7.8	28"	276 lbs	\$7,100	N/A	\$10,810
STK30VS-20-230V-3PH	<b>3 Ton</b>	2 - 21 FPM	20'	Single	208-230/3	4	15.6	28"	276 lbs	\$7,300	N/A	\$11,210
Replace Controls from VS Pendant to 2- Speed Pendant (customer may specify desired low & high speed)										\$200	\$200	\$200

\* For Starke SPT Lug Trolley information, go to page 29.

\*\* For Starke Motorized VS Trolleys information, go to page 30.

# VFD TECHNOLOGY

FEATURING

## DANFOSS DRIVES



### VLT Micro Drive



- Infinite Speed Adjustment
- Improves Load Control
- Soft Start & Stop
- Adjustable Ramp Up & Down
- Adjustable High & Low Speeds

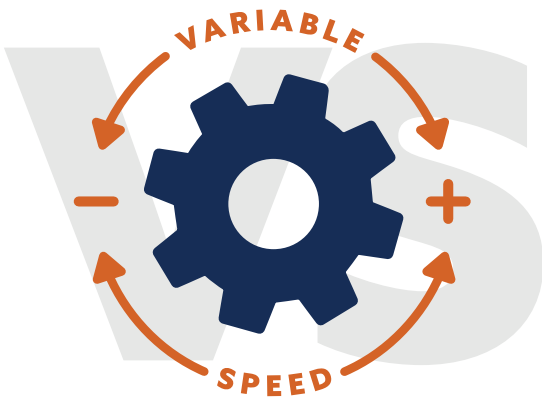

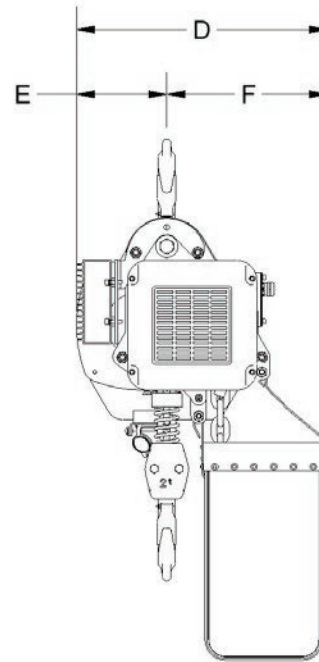
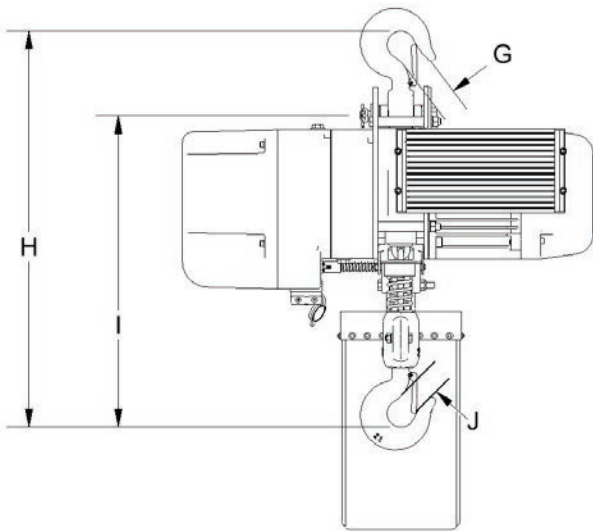
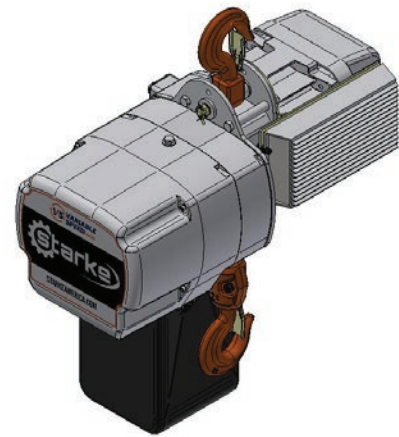
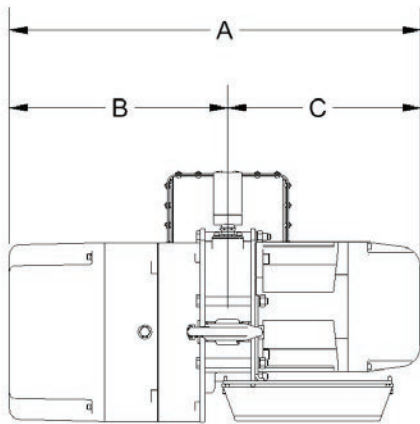

STK VS Series Dimensions									Headroom Dimensions	
	A	B	C	D	E	F	G	J	(I) Lug Pin	(H) Standard
STK05VS	23 <sup>9</sup> / <sub>16</sub> "	13 <sup>1</sup> / <sub>16</sub> "	10 <sup>1</sup> / <sub>2</sub> "	13 <sup>5</sup> / <sub>16</sub> "	4 <sup>7</sup> / <sub>8</sub> "	7 <sup>1</sup> / <sub>4</sub> "	1 <sup>1</sup> / <sub>8</sub> "	1 <sup>1</sup> / <sub>8</sub> "	17 <sup>15</sup> / <sub>16</sub> "	21 <sup>15</sup> / <sub>16</sub> "
STK10VS	24 <sup>5</sup> / <sub>8</sub> "	12 <sup>13</sup> / <sub>16</sub> "	11 <sup>13</sup> / <sub>16</sub> "	12 <sup>1</sup> / <sub>8</sub> "	4 <sup>15</sup> / <sub>16</sub> "	7 <sup>3</sup> / <sub>16</sub> "	1 <sup>1</sup> / <sub>4</sub> "	1 <sup>1</sup> / <sub>4</sub> "	18 <sup>5</sup> / <sub>8</sub> "	23 <sup>1</sup> / <sub>4</sub> "
STK20VS	28 <sup>13</sup> / <sub>16</sub> "	15 <sup>5</sup> / <sub>16</sub> "	13 <sup>1</sup> / <sub>2</sub> "	17 <sup>9</sup> / <sub>16</sub> "	6 <sup>5</sup> / <sub>16</sub> "	11 <sup>1</sup> / <sub>4</sub> "	1 <sup>1</sup> / <sub>2</sub> "	1 <sup>1</sup> / <sub>2</sub> "	21 <sup>13</sup> / <sub>16</sub> "	27 <sup>11</sup> / <sub>16</sub> "
STK30VS	28 <sup>15</sup> / <sub>16</sub> "	15 <sup>7</sup> / <sub>16</sub> "	13 <sup>1</sup> / <sub>2</sub> "	17 <sup>1</sup> / <sub>2</sub> "	6 <sup>3</sup> / <sub>8</sub> "	9 <sup>15</sup> / <sub>16</sub> "	1 <sup>3</sup> / <sub>4</sub> "	1 <sup>3</sup> / <sub>4</sub> "	27 <sup>5</sup> / <sub>8</sub> "	31 <sup>13</sup> / <sub>16</sub> "

**SSP Series**

## Single Phase Electric Chain Hoist



SKU	Cap	Speed	Lift	Voltage	HP	Amp	Headroom	Net Weight	List
SSP1026-10	<b>1000 lb</b>	26 FPM	10'	115/1	1.25	18	18"	89 lbs	\$2,144
SSP1026-15	<b>1000 lb</b>	26 FPM	15'	115/1	1.25	18	18"	95 lbs	\$2,242
SSP1026-20	<b>1000 lb</b>	26 FPM	20'	115/1	1.25	18	18"	101 lbs	\$2,337
SSP2022-10	<b>2000 lb</b>	22 FPM	10'	115/1	1.75	22	21"	127 lbs	\$3,405
SSP2022-15	<b>2000 lb</b>	22 FPM	15'	115/1	1.75	22	21"	133 lbs	\$3,499
SSP2022-20	<b>2000 lb</b>	22 FPM	20'	115/1	1.75	22	21"	139 lbs	\$3,597
SSP4011-10	<b>4000 lb</b>	11 FPM	10'	115/1	1.75	22	26"	152 lbs	\$3,907
SSP4011-15	<b>4000 lb</b>	11 FPM	15'	115/1	1.75	22	26"	165 lbs	\$4,006
SSP4011-20	<b>4000 lb</b>	11 FPM	20'	115/1	1.75	22	26"	178 lbs	\$4,100

- Compact design
- 115V Single Phase
- Fast Speeds
- Quick connect pendant cable
- Canvas chain container
- Use with SST Series Single Phase Trolleys - Page 34
- Twist Lock 115V power cord
- 2,000 lb & 4,000 lb capacity hoists require 30 amp circuit

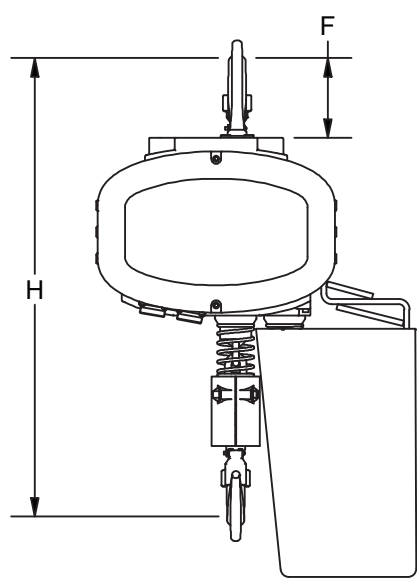
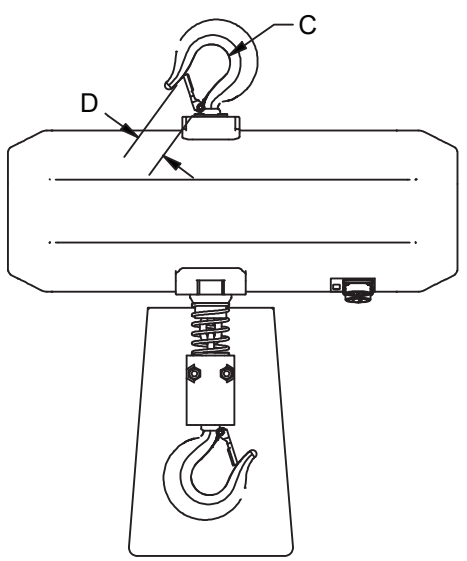
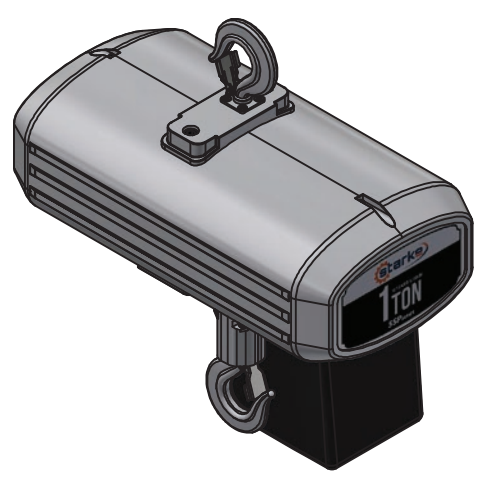
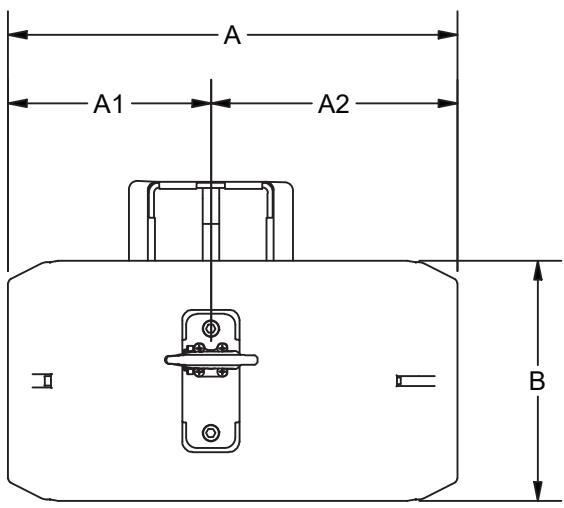

SSP Series Dimensions								
	A	A1	A2	B	C	D	F	H
SSP2022	21 3/8"	9 1/16"	11 1/16"	11"	1 3/4"	1 7/16"	3 13/16"	21 13/16"



### Three Phase / 2-Speed

SKU	Cap	Speed	Lift	Voltage	HP	Amp	Headroom	Net Weight	List
SBH2550-10	<b>250 lb</b>	50/25 FPM	10'	460/3	1	2.1	17"	65 lbs	\$2,587
SBH2550-15	<b>250 lb</b>	50/25 FPM	15'	460/3	1	2.1	17"	67 lbs	\$2,587
SBH2550-20	<b>250 lb</b>	50/25 FPM	20'	460/3	1	2.1	17"	69 lbs	\$2,587
SBH2585-10	<b>250 lb</b>	85/25 FPM	10'	460/3	1	3.7	17"	65 lbs	\$2,513
SBH2585-15	<b>250 lb</b>	85/25 FPM	15'	460/3	1	3.7	17"	67 lbs	\$2,513
SBH2585-20	<b>250 lb</b>	85/25 FPM	20'	460/3	1	3.7	17"	69 lbs	\$2,513
SBH5050-10	<b>500 lb</b>	50/25 FPM	10'	460/3	1	4.9	17"	65 lbs	\$2,587
SBH5050-15	<b>500 lb</b>	50/25 FPM	15'	460/3	1	4.9	17"	67 lbs	\$2,587
SBH5050-20	<b>500 lb</b>	50/25 FPM	20'	460/3	1	4.9	17"	69 lbs	\$2,587

- Compact Design
- 460/3 Phase
- 2 Speed Control Pendant
- 10', 15', 20' chain lengths
- Ideal For Tight Spaces

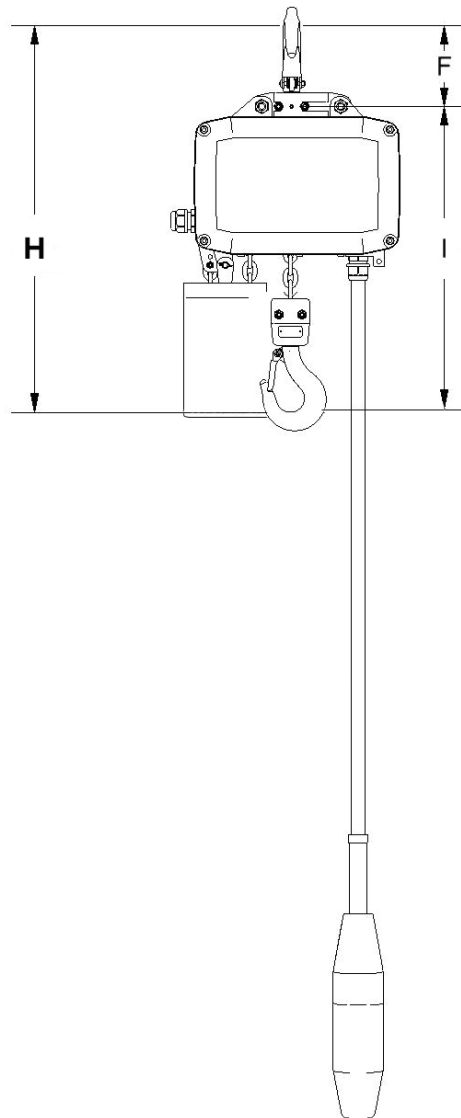
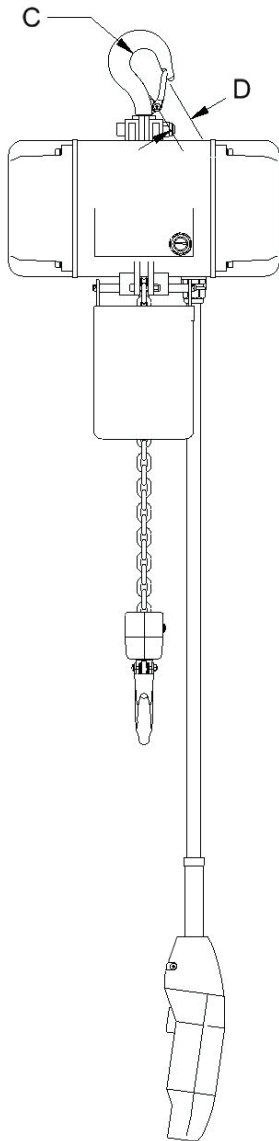
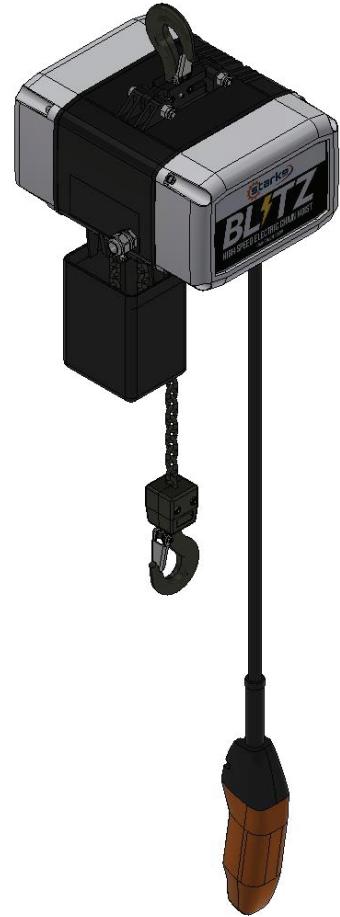
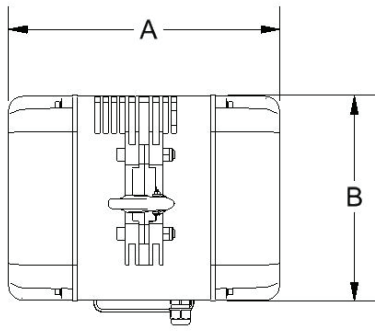

Starke Blitz Dimensions (All Models)					Headroom Dimensions	
A	B	C	D	F	I (Lug Pin)	H (Standard Headroom)
12 7/8"	9 3/4"	1 1/16"	1 1/16"	3 13/16"	13 3/16"	17"



SKU	Cap	Speed	Lift	Voltage	HP	Amp	Headroom	Net Weight	List
SBV0536-10	<b>500 lb</b>	VS 36 FPM	10'	115/1	1.75	18	19"	71 lbs	\$2,884
SBV0536-15	<b>500 lb</b>	VS 36 FPM	15'	115/1	1.75	18	19"	74 lbs	\$2,950
SBV0536-20	<b>500 lb</b>	VS 36 FPM	20'	115/1	1.75	18	19"	77 lbs	\$3,015
SBV1036-10	<b>1000 lb</b>	VS 36 FPM	10'	115/1	1.75	18	19"	76 lbs	\$3,212
SBV1036-15	<b>1000 lb</b>	VS 36 FPM	15'	115/1	1.75	18	19"	82 lbs	\$3,278
SBV1036-20	<b>1000 lb</b>	VS 36 FPM	20'	115/1	1.75	18	19"	88 lbs	\$3,343

- Compact Design
- 115V Single Phase
- VS Speed Control
- 10', 15', 20' chain lengths
- Ideal For Tight Spaces

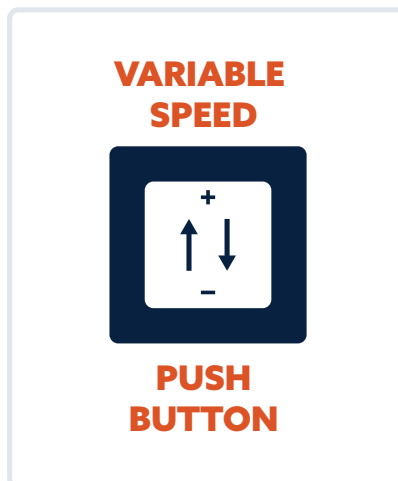

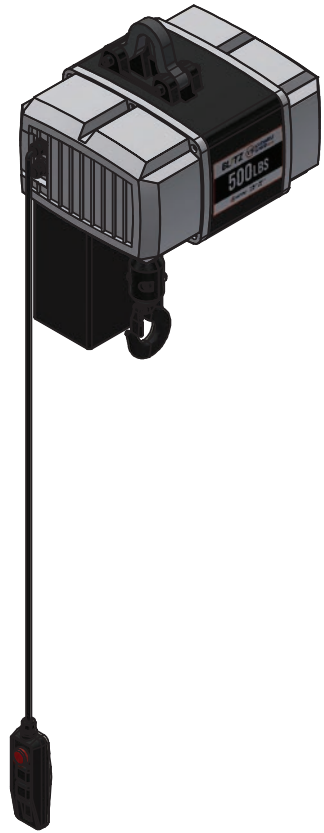
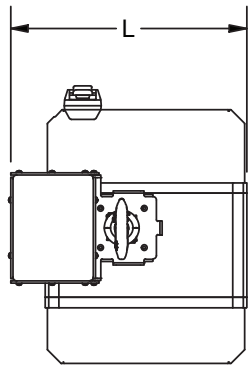
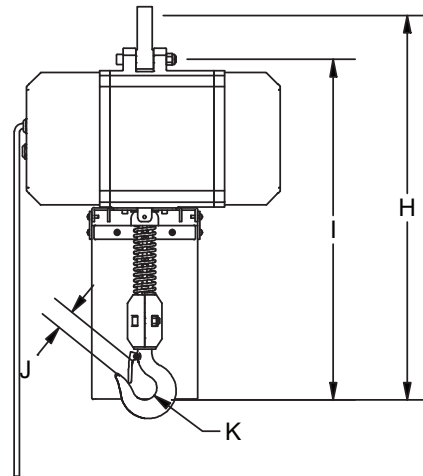
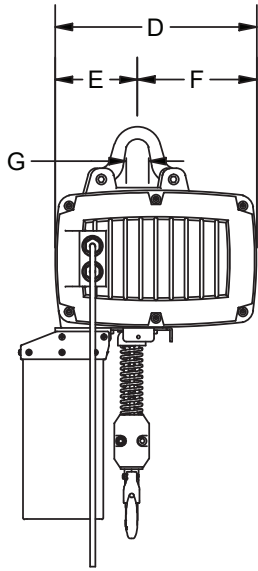
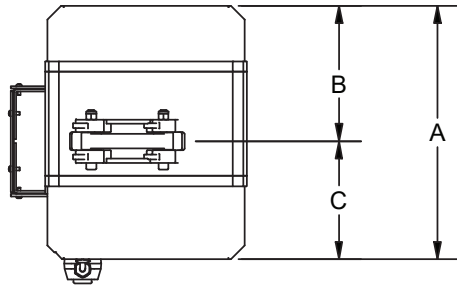

SBV Series Dimensions

	A	B	C	D	E	G	F	H	I	J	K	L
SBV1036	14 3/8"	7 1/16"	6 1/16"	11 7/16"	4 5/8"	1 1/4"	6 3/4"	21 13/16"	19 5/16"	1"	1 9/16"	13 1/4"

# Blitz Smart Lift

## Single Phase Electric Chain Hoist



SKU	Cap	Speed	Lift	Voltage	HP	Amp	Headroom	Net Weight	List
SBVi1036-15	1000 lb	VS 36 FPM	15'	115/1	1.8	18	26"	71 lbs	\$5,965

### Product Features

- Power indicator light at handle control
- Variable speed control
- Contactless magnetic slide handle switch
- Hand presence photo-electric eye for added safety
- Aluminum body for light weight
- Adjustable overload protection provides longer service life
- Sensitivity settings from 1-10
- Lift Speed settings from 1-10
- Height limit settings per operator input
- Load float capable

### Applications

- Automotive parts assembly
- Tool & Die change out
- Product Packaging
- Work shop part positioning
- Warehouse loading
- Parts assembly

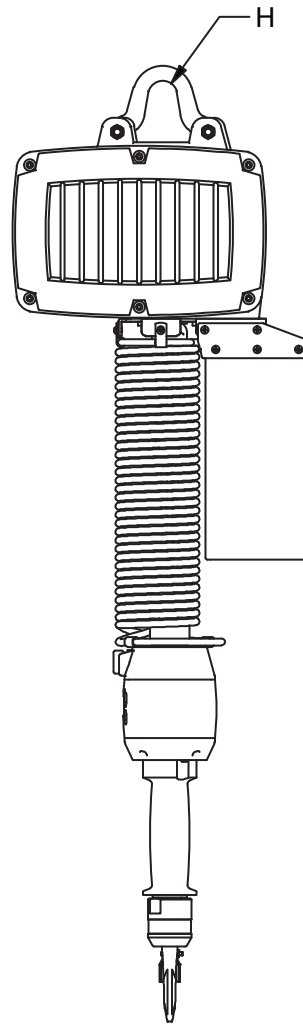
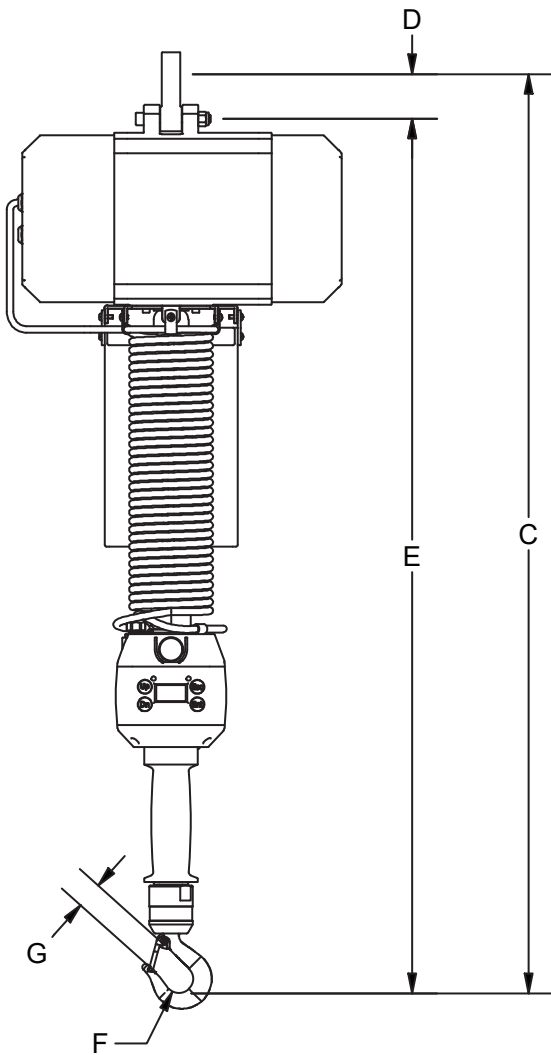
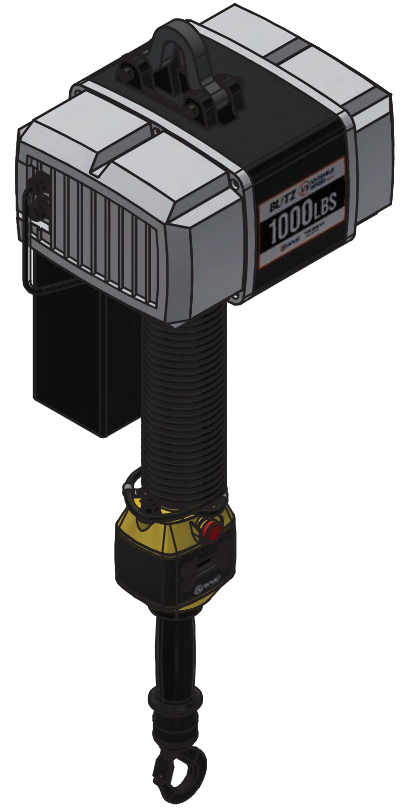
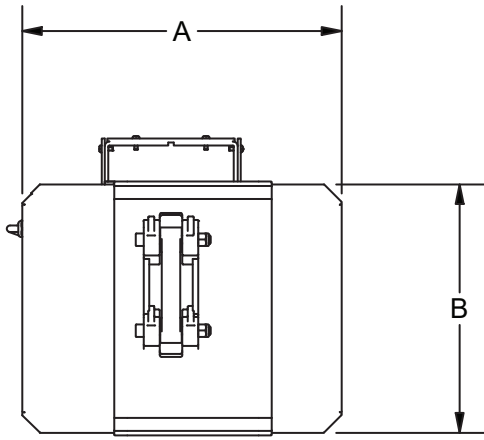

Blitz Smart Lift Dimensions								
	A	B	C	D	E	G	F	H
SBVi1036	14 3/8"	11 3/16"	41 3/8"	2"	39 3/8"	1 3/16"	R 5/8"	R 5/8"

## Work Shop Series

### Single Phase Electric Chain Hoist



SKU	Cap	Speed	Lift	Voltage	HP	Amp	Headroom	Net Weight	List
SSH0513-10	500 lb	13 FPM	10'	115/1	0.5	3.5	15"	31.5 lbs	\$714

- Cost-effective performance
- Lightweight and portable
- User-friendly simplicity
- Smooth and quiet operation
- Plug-and-Play – comes with power cord
- Made for occasional light use applications where headroom and dependability are required

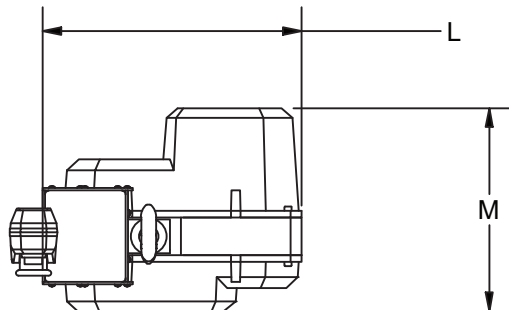
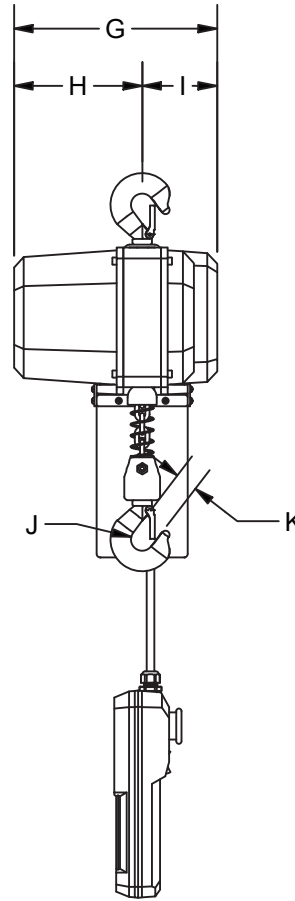
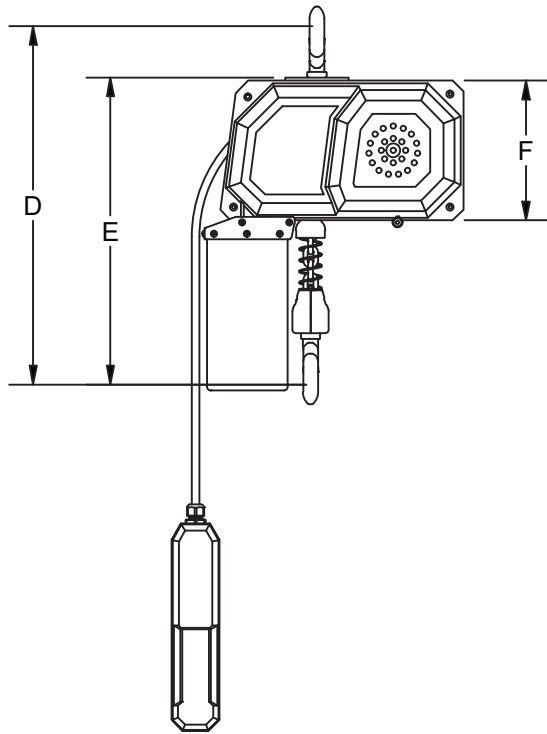
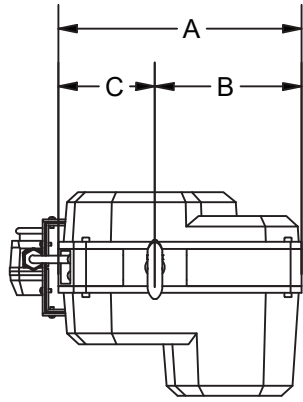
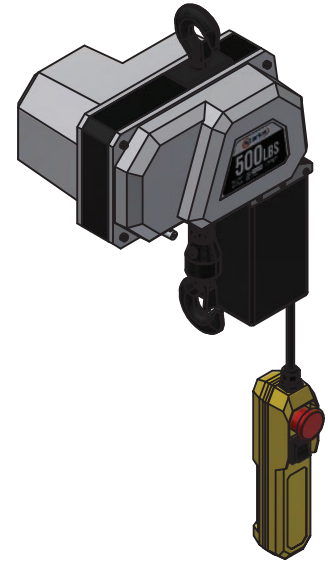

SSH Series Dimensions

	A	B	C	D	E	G	H	I	J	K	L	M
SSH0513	10 5/8"	6 3/8"	4 1/4"	16 5/16"	13 3/4"	8 7/8"	5 5/8"	3 1/4"	R 1/2"	1"	11 5/16"	8 7/8"



### 230V Single Phase / 1-Speed

SKU	Cap	Speed	Lift	Voltage	HP	Amp	Headroom	Net Weight	List
SBS2543-10	250 lb	43 FPM	10'	230/1	0.6	6	17"	65 lbs	\$2,519
SBS2543-15	250 lb	43 FPM	15'	230/1	0.6	6	17"	67 lbs	\$2,666
SBS2543-20	250 lb	43 FPM	20'	230/1	0.6	6	17"	69 lbs	\$2,812
SBS5025-10	500 lb	25 FPM	10'	230/1	0.6	6	17"	65 lbs	\$2,543
SBS5025-15	500 lb	25 FPM	15'	230/1	0.6	6	17"	67 lbs	\$2,689
SBS5025-20	500 lb	25 FPM	20'	230/1	0.6	6	17"	69 lbs	\$2,836
SBS1018-10	1000 lb	18 FPM	10'	230/1	0.6	6	17"	65 lbs	\$2,549
SBS1018-15	1000 lb	18 FPM	15'	230/1	0.6	6	17"	67 lbs	\$2,754
SBS1018-20	1000 lb	18 FPM	20'	230/1	0.6	6	17"	69 lbs	\$2,900

- Compact Design
- 230V Single Phase
- Single Speed Control
- 10', 15', 20' chain lengths
- Ideal For Tight Spaces

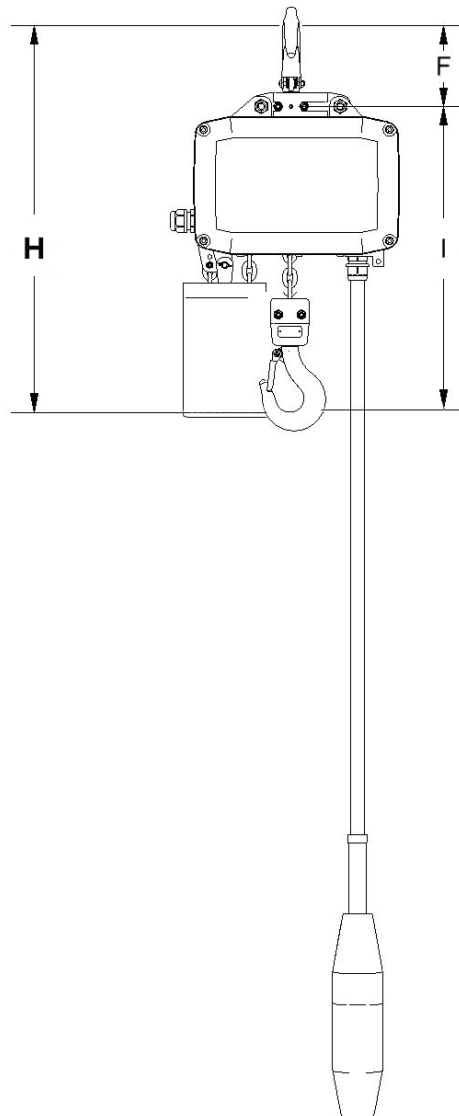
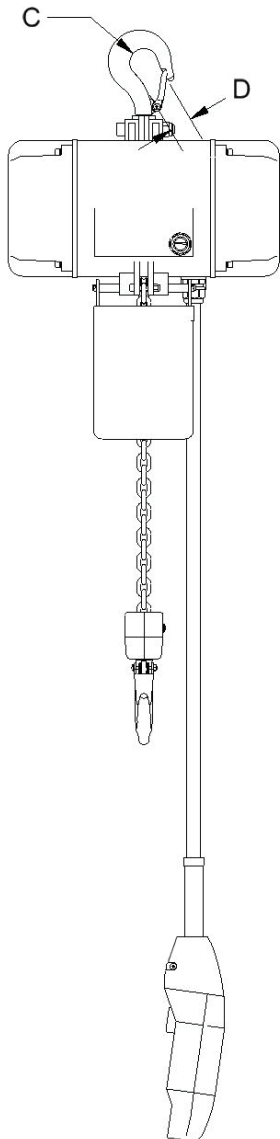
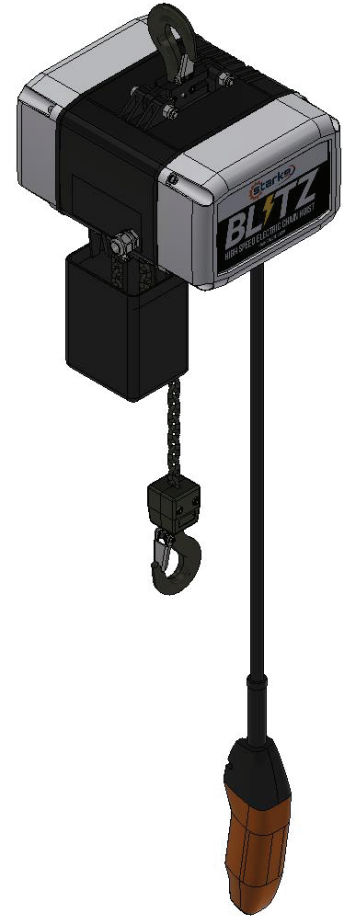
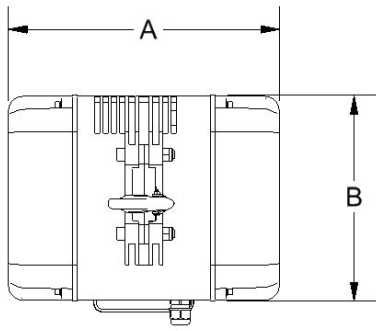

Starke Blitz Dimensions (All Models)					Headroom Dimensions	
A	B	C	D	F	I (Lug Pin)	H (Standard Headroom)
12 7/8"	9 3/4"	1 1/16"	1 1/16"	3 13/16"	13 3/16"	17"

# MANUAL HOIST TROLLEYS

## SHT Series

### Standard Hook-Type Trolley

SKU	Cap	Flange	Min. Beam Height	Min. Radius Curve	Net Weight	List
SHT050	½ Ton	2 ¾" - 8 ¼"	4"	18"	12 lbs	\$165
SHT100	1 Ton	3 ⅞" - 8 ⅝"	5.5"	39"	21 lbs	\$199
SHT200	2 Ton	3 ⅞" - 8 ⅝"	5.5"	42"	30 lbs	\$291
SHT300	3 Ton	3 ⅞" - 8 ⅝"	5.5"	45"	55 lbs	\$476
SHT500	5 Ton	3 ⅞" - 8 ⅝"	7.9"	79"	79 lbs	\$598

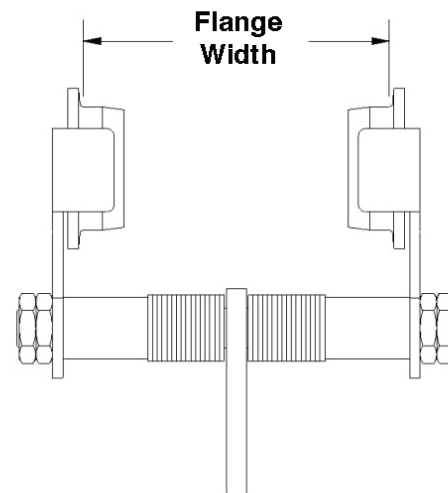
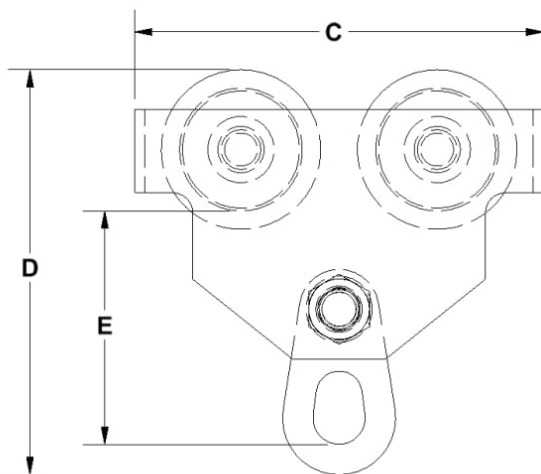
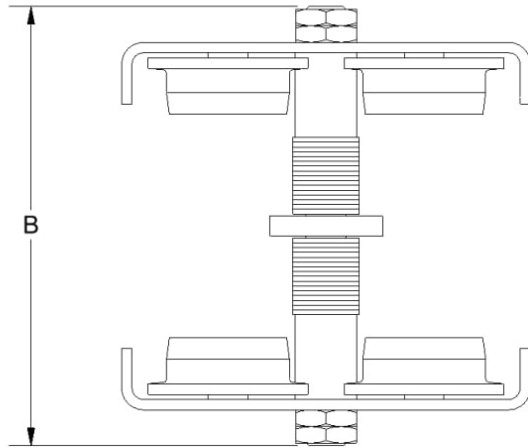

Starke SHT Series Trolley Dimensions

SKU	B	C	D	E
SHT050	8 ¼"	7 ¾"	7 ½"	4 ⅞"
SHT100	9 ½"	9 ⅜"	8 ¼"	4 ⅝"
SHT200	13"	10 ¾"	9 ¼"	5 ⅜"
SHT300	11 ⅝"	12 ⅞"	11 ½"	6 ⅞"
SHT500	13 ⅝"	14 ½"	13 ⅞"	7 ¼"

# SPT Series

## Low Headroom Plain Trolley

Lug Style (Starke Electric Chain Hoists Only)							Clevis Style			Hook-Type Style		
SKU	Cap	Flange Width	Min. Beam Height	Min. Radius Curve	Net Weight	List	SKU	Net Weight	List	SKU	Net Weight	List
SPT025L	¼ Ton	2" - 8 13/16"	4"	27"	21 lbs	\$180	SPT025C	20 lbs	\$229	SPT025H	19 lbs	\$197
SPT050L	½ Ton	2" - 8 13/16"	4"	27"	24 lbs	\$249	SPT050C	23 lbs	\$295	SPT050H	22 lbs	\$262
SPT100L	1 Ton	3" - 8 13/16"	5"	36"	29 lbs	\$221	SPT100C	28 lbs	\$254	SPT100H	27 lbs	\$230
SPT200L	2 Ton	3" - 8 13/16"	6"	45"	49 lbs	\$280	SPT200C	48 lbs	\$307	SPT200H	47 lbs	\$289

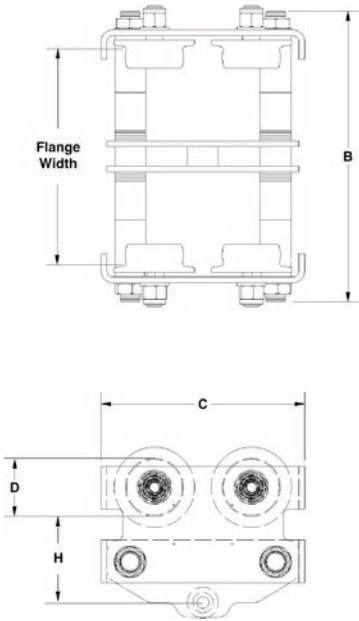

SPT Series Dimensions				
SKU	B	C	D	H
SPT025L	11 3/8"	7 1/2"	2 3/8"	2 1/16"
SPT025C	11 3/8"	7 1/2"	2 3/8"	2 1/4"
SPT025H	11 3/8"	7 1/2"	2 3/8"	2 13/16"
SPT050L	11 3/4"	8 5/16"	2 3/8"	3 1/2"
SPT050C	11 3/4"	8 5/16"	2 3/8"	2 7/16"
SPT050H	11 3/4"	8 5/16"	2 3/8"	3 5/16"
SPT100L	12 3/16"	9 7/8"	2 3/8"	3 7/16"
SPT100C	12 3/16"	9 7/8"	2 3/8"	2 7/16"
SPT100H	12 3/16"	9 7/8"	2 3/8"	3 1/2"
SPT200L	12 7/8"	11 1/16"	3 1/8"	3 7/16"
SPT200C	12 7/8"	11 1/16"	3 1/8"	3"
SPT200H	12 7/8"	11 1/16"	3 1/8"	4 7/16"

Flange Width Adder (For All Styles)			
SKU	Cap	Flange Width Range	List
SPT025FW12	¼ Ton	8 3/4" - 12"	\$166
SPT050FW12	½ Ton	8 3/4" - 12"	\$199
SPT100FW12	1 Ton	8 3/4" - 12"	\$230
SPT200FW12	2 Ton	8 3/4" - 12"	\$358

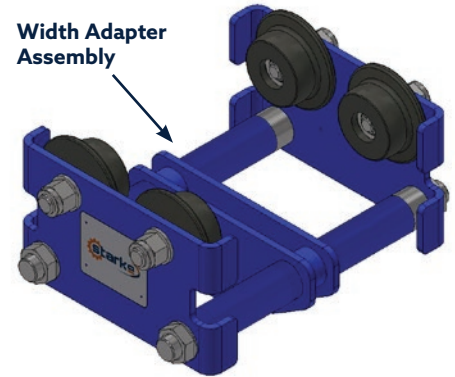

### Lug Mount ("L" - SKU)

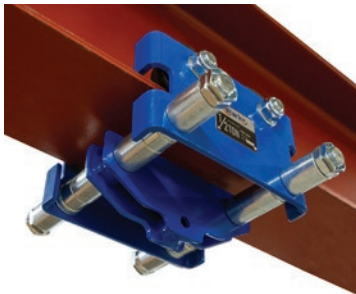

\*Lug mount adapts directly to Starke STK and Blitz Series Hoists only

### Clevis Mount ("C" - SKU)

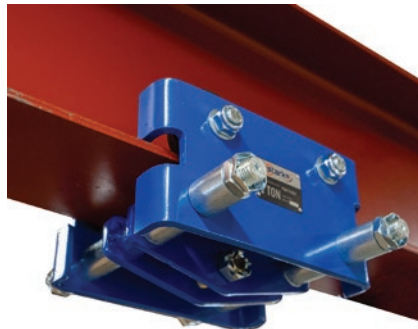

\*Clevis mounts to typical hoist hook on most brands and models to maximize headroom

### Hook-Type ("H" - SKU)



\*Hook-Type mount allows users to utilize this model for all brands with standard headroom

# MOTORIZED HOIST TROLLEYS

## SMT Series - VFD Controlled 2-Speed Motorized Trolley

Wide Flange and Standard Beams

Lug Style										Clevis Style		
SKU	Cap	2 - Speed	Voltage	Min. Radius Curve	Flange Width Range	HP	Amp	Net Weight	List	Clevis Style SKU	List	Head-room
SMT10VSL-460V-3PH	1 Ton	82/14 FPM	460/3	32"	3"- 7 3/4"	1/2	1.1	92 lbs	\$3,009	SMT10VSC-460V-3PH	\$3,148	24"
SMT10VSL-230V-3PH	1 Ton	82/14 FPM	208-230/3	32"	3"- 7 3/4"	1/2	2.2	92 lbs	\$3,209	SMT10VSC-230V-3PH	\$3,348	24"
SMT10VSL-230V-1PH	1 Ton	82/14 FPM	230/1	32"	3"- 7 3/4"	1/2	4.4	92 lbs	\$3,309	SMT10VSC-230V-1PH	\$3,448	24"
SMT20VSL-460V-3PH	2 Ton	82/14 FPM	460/3	32"	4"- 9 1/4"	1/2	1.1	114 lbs	\$3,526	SMT20VSC-460V-3PH	\$3,665	28"
SMT20VSL-230V-3PH	2 Ton	82/14 FPM	208-230/3	32"	4"- 9 1/4"	1/2	2.2	114 lbs	\$3,726	SMT20VSC-230V-3PH	\$3,865	28"
SMT20VSL-230V-1PH	2 Ton	82/14 FPM	230/1	32"	4"- 9 1/4"	1/2	4.4	114 lbs	\$3,826	SMT20VSC-230V-1PH	\$3,965	28"
SMT30VSL-460V-3PH	3 Ton	82/14 FPM	460/3	40"	4"- 9 1/2"	1	2.2	123 lbs	\$3,710	SMT30VSC-460V-3PH	\$3,849	29"
SMT30VSL-230V-3PH	3 Ton	82/14 FPM	208-230/3	40"	4"- 9 1/2"	1	4.4	123 lbs	\$3,910	SMT30VSC-230V-3PH	\$4,049	29"
SMT30VSL-230V-1PH	3 Ton	82/14 FPM	230/1	40"	4"- 9 1/2"	1	8.8	123 lbs	\$4,010	SMT30VSC-230V-1PH	\$4,149	29"
SMT50VSL-460V-3PH	5 Ton	82/14 FPM	460/3	72"	4"- 10 9/16"	1	2.2	183 lbs	\$4,173	SMT50VSC-460V-3PH	\$4,300	37"
SMT50VSL-230V-3PH	5 Ton	82/14 FPM	208-230/3	72"	4"- 10 9/16"	1	4.4	183 lbs	\$4,373	SMT50VSC-230V-3PH	\$4,500	37"
SMT50VSL-230V-1PH	5 Ton	82/14 FPM	230/1	72"	4"- 10 9/16"	1	8.8	183 lbs	\$4,473	SMT50VSC-230V-1PH	\$4,600	37"

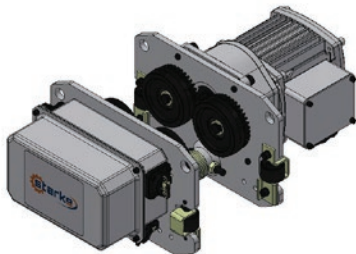

Flange Width Adder (up to 12")				Flange Width Adder (up to 12" - 16")		
SKU	Cap	Flange Range	List	SKU	Flange Range	List
SMT10FW12	1 Ton	7 3/4"-12"	\$222	SMT10FW16	12"-16"	\$278
SMT20FW12	2 Ton	9 1/4"-12"	\$258	SMT20FW16	12"-16"	\$319
SMT30FW12	3 Ton	9 1/2"-12"	\$294	SMT30FW16	12"-16"	\$366
SMT50FW12	5 Ton	10 9/16"-12"	\$348	SMT50FW16	12"-16"	\$427

**VFD TECHNOLOGY**  
FEATURING  
**DANFOSS DRIVES**



**Danfoss**

### VLT Micro Drive

- Infinite Speed Adjustment
- Improves Load Control
- Soft Start & Stop
- Adjustable Ramp Up & Down
- Adjustable High & Low Speeds

## LUG STYLE

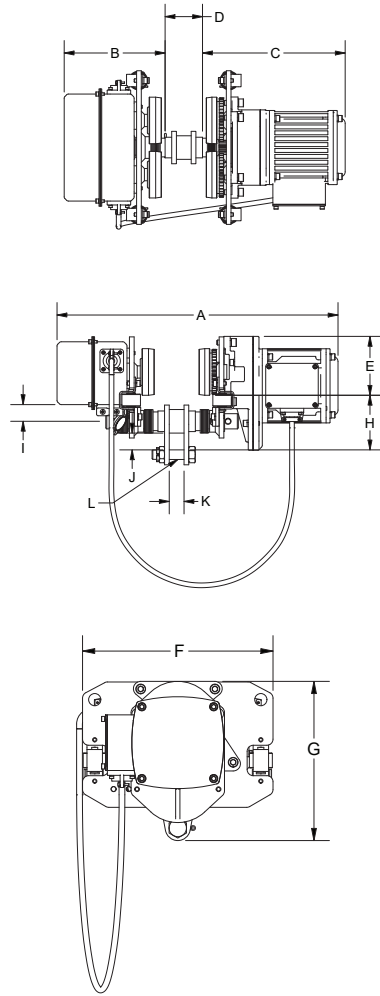

## CLEVIS STYLE

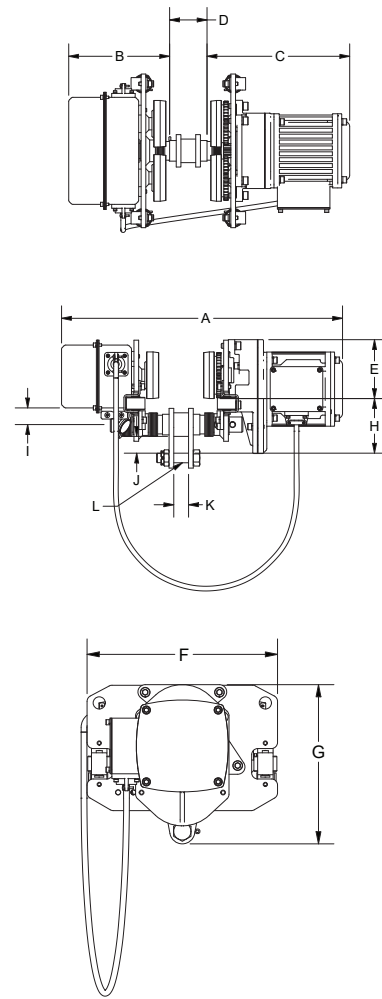

Starke SMT Trolley (Lug Series) Dimensions

SKU	A	B	C	D	E	F	G	H	I	J	K
SMT10VSL	18 15/16" – 24 11/16"	7 3/16" – 11 7/8"	10 9/16" – 13 7/16"	1 1/4"	4 3/4"	12 5/16"	10 9/16"	5 1/8"	1 5/16"	2 5/16"	1/2"
SMT20VSL	20 5/16" – 25 1/2"	7 1/8" – 8 11/16"	12 1/16" – 13 5/8"	1 1/16"	4 11/16"	12 13/16"	11 1/2"	5 3/8"	1 3/4"	2 1/4"	13/16"
SMT30VSL	20 5/8" – 25 5/8"	7 3/8" – 8 3/4"	12 1/8" – 13 1/2"	1 1/16"	5 1/8"	13 7/16"	12 13/16"	6 1/2"	2 3/16"	2 13/16"	13/16"
SMT50VSL	21 9/16" – 30 9/16"	8 1/16" – 12 1/2"	11 3/4" – 16 1/4"	1 13/16"	5 3/4"	15 13/16"	14 5/16"	7 5/16"	3 5/16"	3 1/16"	13/16"

Starke SMT Trolley (Clevis Series) Dimensions

SKU	A	B	C	D	E	F	G	H	I	J	K	L
SMT10VSC	20 1/4" – 24 11/16"	5 15/16" – 8 1/8"	8 13/16" – 11 1/16"	3"	4 3/4"	12 5/16"	10 5/16"	4 1/2"	1 3/8"	1 3/8"	1 3/16"	3/4" BOLT
SMT20VSC	21 5/8" – 25 1/2"	7 5/8" – 9"	10 5/8" – 13 1/4"	3"	4 11/16"	12 13/16"	11 7/16"	5 1/16"	1 3/4"	1 9/16"	1 3/8"	7/8" BOLT
SMT30VSC	22 7/16" – 25 5/8"	7 5/8" – 10 15/16"	11 1/8" – 13 5/16"	3 1/2"	5 1/8"	13 7/16"	12 5/8"	5 7/8"	2 3/16"	1 11/16"	1 1/16"	1" BOLT
SMT50VSC	24" – 29 9/16"	8 1/16" – 10 13/16"	11 3/4" – 14 1/2"	4 1/4"	5 3/4"	15 13/16"	15 3/4"	7"	3 5/16"	2 7/8"	2"	1 1/4" BOLT

# Corrosion Resistant SMT Series - VFD Controlled 2-Speed Motorized Trolley

## Wide Flange and Standard Beams



Lug Style										Clevis Style		
SKU	Cap	2 - Speed	Voltage	Min. Radius Curve	Flange Width Range	HP	Amp	Net Weight	List	SKU	List	Headroom
SMT10VSL-CR	1 Ton	82/14 FPM	460/3	32"	3" - 7 ¾"	½	1.1	92 lbs	\$3,574	SMT10VSC-CR	\$3,703	24"
SMT20VSL-CR	2 Ton	82/14 FPM	460/3	32"	3" - 7 ¾"	½	1.1	114 lbs	\$4,044	SMT20VSC-CR	\$4,173	28"
SMT30VSL-CR	3 Ton	82/14 FPM	460/3	40"	4" - 9 ½"	1	2.2	123 lbs	\$4,212	SMT30VSC-CR	\$4,341	29"
SMT50VSL-CR	5 Ton	82/14 FPM	460/3	72"	4" - 10 ⅝"	1	2.2	183 lbs	\$5,461	SMT50VSC-CR	\$5,590	37"

- Primer Paint: Anti-Rust & Anti-Corrosion Epoxy Paint
- Stainless steel wheels
- Stainless steel main support pin
- The corrosion-resistant units **do not** come with food grade oil and grease. **Food Grade** must include: Food Grade Oil and Grease.

## LUG STYLE

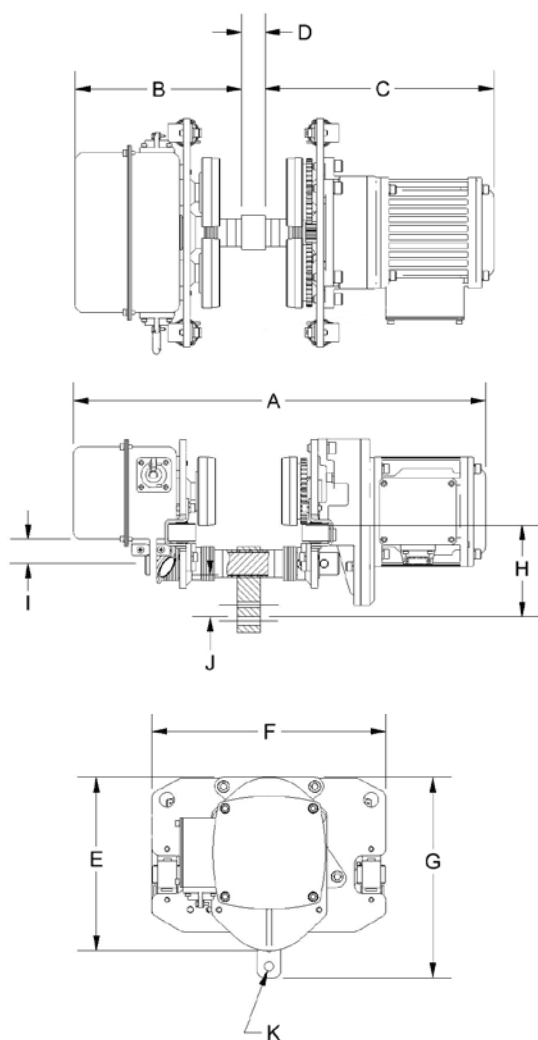

## CLEVIS STYLE

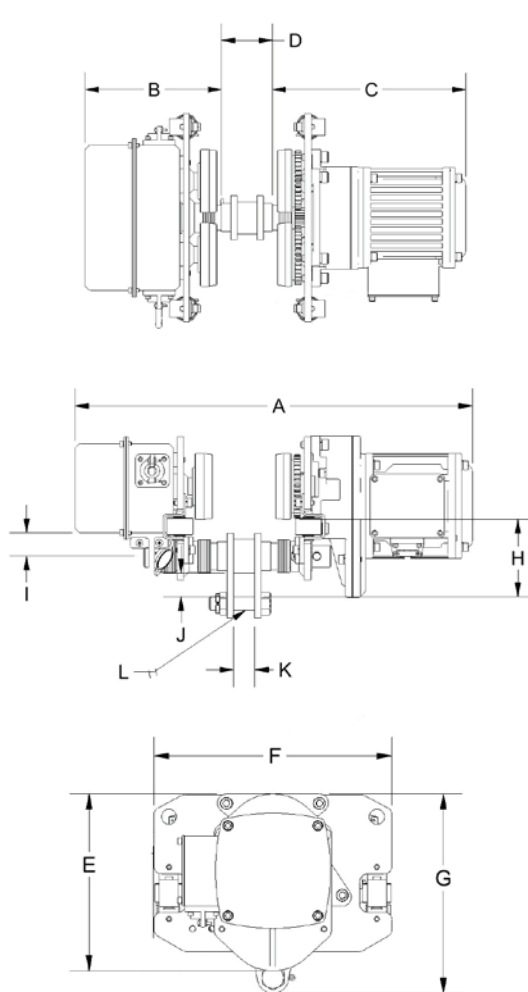

**Starke SMT Trolley (Lug Series) Dimensions**

SKU	A	B	C	D	E	F	G	H	I	J	K
SMT10VSL-CR	18 15/16" – 24 1/16"	7 3/16" – 11 7/8"	10 9/16" – 13 7/16"	1 1/4"	9 1/8"	12 5/16"	10 9/16"	5 1/8"	1 5/16"	2 5/16"	1/2"
SMT20VSL-CR	20 5/16" – 25 1/2"	7 1/8" – 8 1/16"	12 1/16" – 13 5/8"	1 1/16"	9 5/8"	12 13/16"	11 1/2"	5 3/8"	1 3/4"	2 1/4"	13/16"
SMT30VSL-CR	20 5/8" – 25 5/8"	7 3/8" – 8 3/4"	12 1/8" – 13 1/2"	1 1/16"	9 13/16"	13 7/16"	12 13/16"	6 1/2"	2 3/16"	2 13/16"	13/16"
SMT50VSL-CR	21 9/16" – 30 9/16"	8 1/16" – 12 1/2"	11 3/4" – 16 1/4"	1 13/16"	9"	15 13/16"	14 5/16"	7 5/16"	3 5/16"	3 1/16"	13/16"

**Starke SMT Trolley (Clevis Series) Dimensions**

SKU	A	B	C	D	E	F	G	H	I	J	K	L
SMT10VSC-CR	20 1/4" – 24 1/16"	5 15/16" – 8 1/8"	8 13/16" – 11 1/16"	3"	9 1/8"	12 5/16"	10 5/16"	4 1/2"	1 3/8"	1 3/8"	1 3/16"	3/4" BOLT
SMT20VSC-CR	21 5/8" – 25 1/2"	7 5/8" – 9"	10 5/8" – 13 1/4"	3"	9 5/8"	12 13/16"	11 7/16"	5 1/16"	1 3/4"	1 9/16"	1 3/8"	7/8" BOLT
SMT30VSC-CR	22 7/16" – 25 5/8"	7 5/8" – 10 15/16"	11 1/8" – 13 5/16"	3 1/2"	9 13/16"	13 7/16"	12 5/8"	5 7/8"	2 3/16"	1 11/16"	1 9/16"	1" BOLT
SMT50VSC-CR	24" – 29 9/16"	8 1/16" – 10 13/16"	11 3/4" – 14 1/2"	4 1/4"	9"	15 13/16"	15 3/4"	7"	3 5/16"	2 7/8"	2"	1 1/4" BOLT

# SST Series - 115V Single Phase Motorized Trolley

Wide Flange and Standard Beams



Lug Style										Clevis Style		
SKU	Cap	Speed	Voltage	Min. Radius Curve	Flange Width Range	HP	Amp	Net Weight	List Price	Clevis Style SKU	List Price	Headroom
SST1034TRL	1,000 lb	34 FPM	115/1	30"	5 1/8" - 8 3/4"	0.35	2.17	83 lbs	\$1,506	SST1034TRC	\$1,506	5 1/8"
SST2034TRL	2,000 lb	34 FPM	115/1	30"	5 1/8" - 8 3/4"	0.35	2.17	83 lbs	\$1,652	SST2034TRC	\$1,652	5 1/8"
SST4034TRL	4,000 lb	34 FPM	115/1	120"	5 1/2" - 8 1/2"	0.35	2.17	93 lbs	\$1,904	SST4034TRC	\$1,904	5 1/8"

- Single speed motorized trolley
- Lug attachment to SSP Hoist included
- Low headroom clearance
- 34 FPM single speed travel
- Clevis style available for other brands of hoists
- Rubber bumpers and safety bracket included

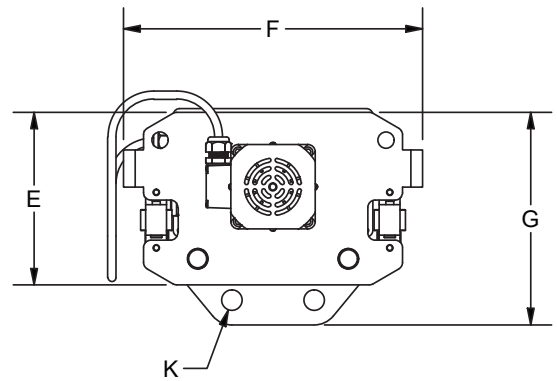
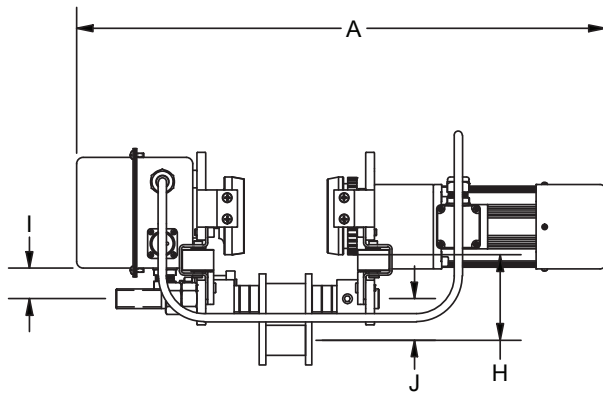
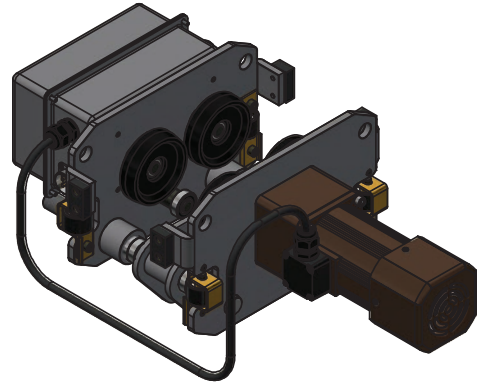
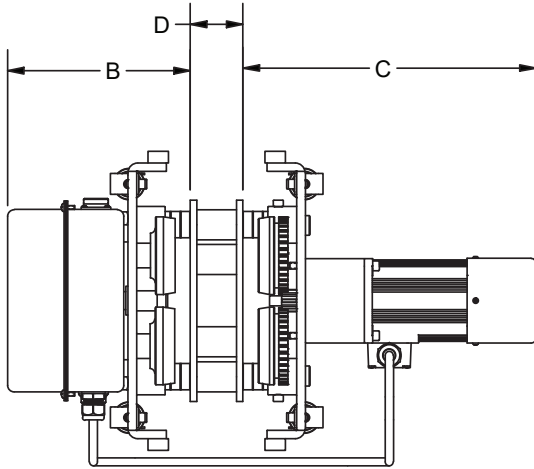

SST Series Dimensions									
	A	B	C	D	E	G	H	J	K
SST2024	25 5/16"	8 3/4"	14 1/16"	2 1/2"	8 1/4"	10 3/16"	4 1/16"	2"	1"

# DRIVE BEAM TRACTOR

Wide Flange Beams Only



**VFD TECHNOLOGY** FEATURING  
**DANFOSS DRIVES**

## VLT Micro Drive

- Infinite Speed Adjustment
- Improves Load Control
- Soft Start & Stop
- Adjustable Ramp Up & Down
- Adjustable High & Low Speeds



SKU	Cap	2 - Speed	Flange Range	HP	Amp	Voltage	Net Weight	List
SBT30VS-460V-3PH	3 Ton	82/14 FPM	4" - 8"	1	2.2	460/3	143 lbs	\$3,820
SBT30VS-230V-3PH	3 Ton	82/14 FPM	4" - 8"	1	4.4	208-230/3	143 lbs	\$4,020
SBT30VS-230V-1PH	3 Ton	82/14 FPM	4" - 8"	1	8.8	230/1	143 lbs	\$4,120

## Flange Width Adder

SKU	Cap	Flange Range	List
SBT30FW12	3 Ton	8"-12"	\$345

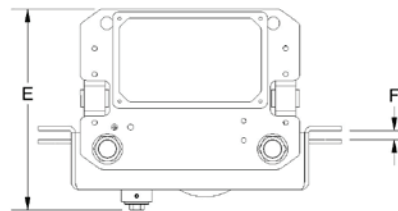
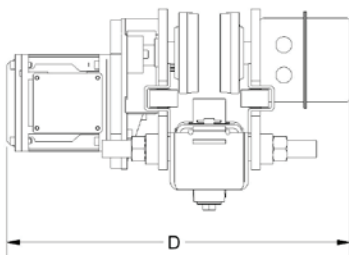
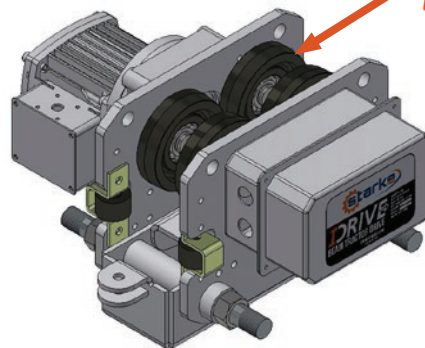
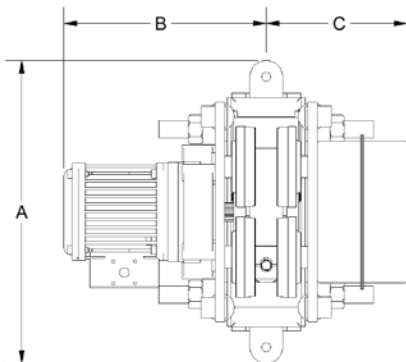
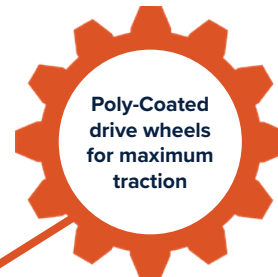

I-Drive Beam Tractor Dimensions

	A	B	C	D	E	F
SBT30VS	18 1/2"	12 3/8" MIN 14 1/8" MAX	8 5/8" MIN 10 3/8" MAX	21" MIN 24 1/2" MAX	12 5/16"	9/16"

# UPGRADES & CONTROLS

## Hoist Chain

SKU	Diameter	Grade	Working Load Limit	Compatible Hoist Models	Net Weight/ft	List
SLC80-05	5.0 mm	#80	1,100 lbs	Starke 250, 500, 1000 Blitz Hoists	0.37 lbs	\$23.66 / ft
SLC80-06	6.3 mm	#80	1,525 lbs	Starke ½ Ton STK & VS Hoists	0.57 lbs	\$25.21 / ft
SLC80-07	7.1 mm	#80	2,200 lbs	Starke 1 Ton STK & VS Hoists	0.77 lbs	\$31.40 / ft
SLC80-10	10.0 mm	#80	4,400 lbs	Starke 2 Ton STK & VS Hoists	1.43lbs	\$34.79 / ft
SLC80-11	11.2 mm	#80	6,600 lbs	Starke 3 - 5 Ton STK & VS Hoists	1.8 lbs	\$37.74 / ft



## External Strain Relief Pendant Cable

SKU	Length	# of wires	Net Weight	Price per ft	List
SPCE06-1	per foot	6	0.15 lbs	\$4.26	\$4.26
SPCE06-50	50'	6	7.5 lbs	\$3.67	\$183.00
SPCE06-100	100'	6	15 lbs	\$3.40	\$340.00
SPCE06-250	250'	6	37.5 lbs	\$3.13	\$782.00
SPCE10-1	per foot	10	0.24 lbs	\$7.25	\$7.25
SPCE10-50	50'	10	12 lbs	\$6.23	\$311.00
SPCE10-100	100'	10	24 lbs	\$5.74	\$574.00
SPCE10-250	250'	10	60 lbs	\$5.27	\$1,317.00



6 Wire



10 Wire

## Hoist Pendants (Pendant Only)

SKU	Motion	Speed	Type	Net Weight	List
S2B1SP	1 Motion	1 Speed	w/ E Stop	.73 lbs	\$97
S2B2SP	1 Motion	2 Speed	w/ E Stop	.94 lbs	\$122
S2BVSPD	1 Motion	Variable	w/ E Stop	1.35 lbs	\$159
S4B1SP	2 Motion	1 Speed	w/ E Stop	1.82 lbs	\$146
S4BVSPD	2 Motion	Variable	w/ E Stop	1.96 lbs	\$188
S6B2SP	3 Motion	2 Speed	w/ E Stop	2.34 lbs	\$305
600-60061	10-Pin Pendant Aviation Plug		Female	.13 lbs	\$34
600-60060	10-Pin Pendant Aviation Plug		Male	.155 lbs	\$34



S2B1SP



S2BVSPD



S4BVSPD



S4B1SP



S6B2SP



Male  
(10-Pin)



Female  
(10-Pin)

## Standard Lift – Canvas Chain Containers

SKU	Tag Number	Frame Size	Bucket Length	Material	Compatible Hoist Models	Net Weight	List
SCC-412B	N/A	4" x 4.5"	12"	Canvas	SBH25 @ 20' Max Lift SBH50 @ 20' Max Lift SBS10 @ 20' Max Lift	1.3 lbs	\$62
SCC-0811	8	6" x 6"	11"	Canvas	STK10 @ 26' Max Lift STK20 @ 13' Max Lift	1.5 lbs	\$77
SCC-1213	12	8.5" x 8.5"	13"	Canvas	STK10 @ 39' Max Lift STK20 @ 20' Max Lift STK30 @ 13' Max Lift	3.5 lbs	\$99
SCC-1416	14	8.5" x 8.5"	16"	Canvas	STK10 @ 46' Max Lift STK20 @ 26' Max Lift STK 30 @ 20' Max Lift	3.8 lbs	\$118
SCC-1622	16	8.5" x 8.5"	22"	Canvas	STK20 @ 52' Max Lift STK30 @ 39' Max Lift STK50 @ 26' Max Lift	4.1 lbs	\$148
SCC-1836	18	8.5" x 8.5"	36"	Canvas	STK20 @ 69' Max Lift STK30 @ 46' Max Lift STK50 @ 32' Max Lift	5.4 lbs	\$191



## Extended Lift – Metal Chain Containers

SKU	Frame Size	Bucket Length	Material	Compatible Hoist Models	Net Weight	List
SCC-21M	8" x 16"	21"	Mild Steel	STK20 @ 175' Max Lift STK30 @ 100' Max Lift	30 lbs	\$455
SCC-23M	8" x 16"	23"	Mild Steel	STK20 @ 200' Max Lift STK30 @ 125' Max Lift STK50 @ 60' Max Lift	32 lbs	\$468
SCC-25M	8" x 16"	25"	Painted Steel	STK20 @ 225' Max Lift STK30 @ 150' Max Lift STK50 @ 70' Max Lift	34 lbs	\$486
SCC-27M	8" x 16"	27"	Painted Steel	STK20 @ 250' Max Lift STK30 @ 175' Max Lift STK50 @ 80' Max Lift	36 lbs	\$504
SCC-29M	8" x 16"	29"	Mild Steel	STK30 @ 200' Max Lift STK50 @ 100' Max Lift	38 lbs	\$488



## Canvas Hoist Weather Covers

SKU	Material	Compatible Hoist Models	Net Weight/ft	List
SHWC-02S	Canvas	All Blitz Hoists	1 lbs	\$303
SHWC-05M	Canvas	STK05 Series	1.5 lbs	\$352
SHWC-10L	Canvas	STK10 Series	1.75 lbs	\$366
SHWC-20L	Canvas	STK20, 30, 50 Series	2 lbs	\$404





## Amp Draw Chart

Horsepower (hp)	60 HZ AC Induction Motor				
	Single Phase		Three Phase		
	115 Volt	230 Volt	208 Volt	230 Volt	460 Volt
1/6	4.4	2.2	~	~	~
1/4	5.8	2.9	~	~	~
1/3	7.2	3.6	~	~	~
1/2	9.8	4.9	2.5	2.2	1.1
3/4	13.8	6.9	3.7	3.2	1.6
1	16	8	4.8	4.2	2.1
1 1/2	20	10	6.9	6	3
2	24	12	7.8	6.8	3.4
3	34	17	11	9.6	4.8
4	44	22	14	12.6	6.3
5	56	28	17.5	15.2	7.6
7 1/2	80	40	25	22	11
10	100	50	32	28	14
15	135	68	48	42	21
20	~	88	62	54	27
25	~	110	78	68	34
30	~	136	92	80	40
40	~	176	120	104	52
50	~	225	144	130	65

# SMW SERIES

## MONORAIL WIRE ROPE HOIST



Model	Cap	Lift (ft)	HMI Duty Rating	Flange Range	Lifting Speed	Lifting Motor (HP)	Travel Speed	Trolley Motor (HP)	Weight	List
SMW0322-20-460V-3PH	3 Ton	20'	H4	8" - 20"	22/4 FPM	4	75/20 FPM	0.5	765 lbs	\$9,405
SMW0322-30-460V-3PH	3 Ton	30'	H4	8" - 20"	22/4 FPM	4	75/20 FPM	0.5	801 lbs	\$9,790
SMW0322-40-460V-3PH	3 Ton	40'	H4	8" - 20"	22/4 FPM	4	75/20 FPM	0.5	849 lbs	\$10,176
SMW0524-20-460V-3PH	5 Ton	20'	H4	8" - 25"	24/4 FPM	8	75/20 FPM	0.85	911 lbs	\$10,005
SMW0524-30-460V-3PH	5 Ton	30'	H4	8" - 25"	24/4 FPM	8	75/20 FPM	0.85	959 lbs	\$10,533
SMW0524-40-460V-3PH	5 Ton	40'	H4	8" - 25"	24/4 FPM	8	75/20 FPM	0.85	1,019 lbs	\$11,061
SMW0721-20-460V-3PH	7.5 Ton	20'	H4	8" - 25"	21/4 FPM	15	75/20 FPM	1.3	1,795 lbs	\$18,915
SMW0721-30-460V-3PH	7.5 Ton	30'	H4	8" - 25"	21/4 FPM	15	75/20 FPM	1.3	1,867 lbs	\$19,556
SMW0721-40-460V-3PH	7.5 Ton	40'	H4	8" - 25"	21/4 FPM	15	75/20 FPM	1.3	1,964 lbs	\$20,198
SMW1021-20-460V-3PH	10 Ton	20'	H4	8" - 25"	21/4 FPM	15	75/20 FPM	1.3	1,795 lbs	\$15,690
SMW1021-30-460V-3PH	10 Ton	30'	H4	8" - 25"	21/4 FPM	15	75/20 FPM	1.3	1,867 lbs	\$16,222
SMW1021-40-460V-3PH	10 Ton	40'	H4	8" - 25"	21/4 FPM	15	75/20 FPM	1.3	1,964 lbs	\$16,754
SMW1521-20-460V-3PH	15 Ton	20'	H4	8" - 25"	21/4 FPM	16.7	75/20 FPM	2	1,850 lbs	\$27,239
SMW1521-30-460V-3PH	15 Ton	30'	H4	8" - 25"	21/4 FPM	16.7	75/20 FPM	2	1,923 lbs	\$27,862
SMW1521-40-460V-3PH	15 Ton	40'	H4	8" - 25"	21/4 FPM	16.7	75/20 FPM	2	1,996 lbs	\$28,485



48 Hour Quick Ship | Models Highlighted Above

- Estimated lead time for non-stock models: 12 Weeks
- Standard voltage for all models listed above is 460V-3 phase.
- All models include Load Cell with 3" LED Display showing Live Load Lbs.
- For additional or custom capacity and lift heights (50', 60', 70', 80'), please contact your distributor.
- Wire rope hoists (7.5 Ton and larger) have VFD controlled lifting and VFD trolley

## Flange Width Adder

SKU	Cap	Flange Range	List
SMW03FW27	3 Ton	20" - 27"	\$2,056
SMW05FW27	5 Ton	25" - 31"	\$2,271
SMW07FW27	7.5 Ton	25" - 31"	\$2,383
SMW10FW27	10 Ton	25" - 31"	\$2,383
SMW15FW27	15 Ton	25" - 31"	\$2,498

## VFD Lift Adder

SKU	Cap	List
SMW0322	3 Ton	\$1,500
SMW0524	5 Ton	\$2,100



**Standard VFD  
Lift & Trolley Motion**  
(7.5 Ton and Greater Capacities)

**VFD TECHNOLOGY**  
FEATURING  
**DANFOSS DRIVES**

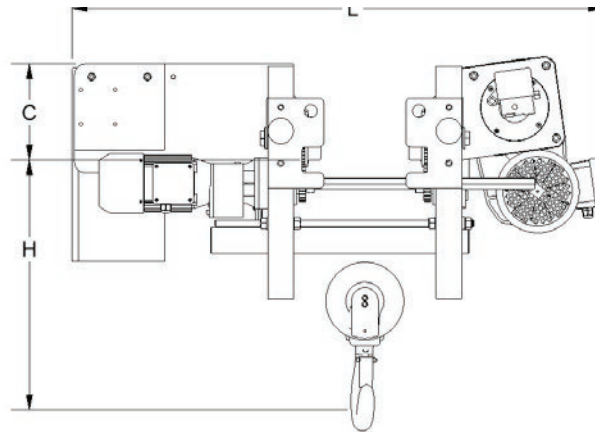
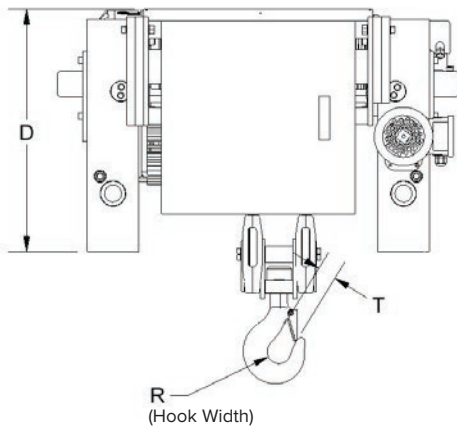
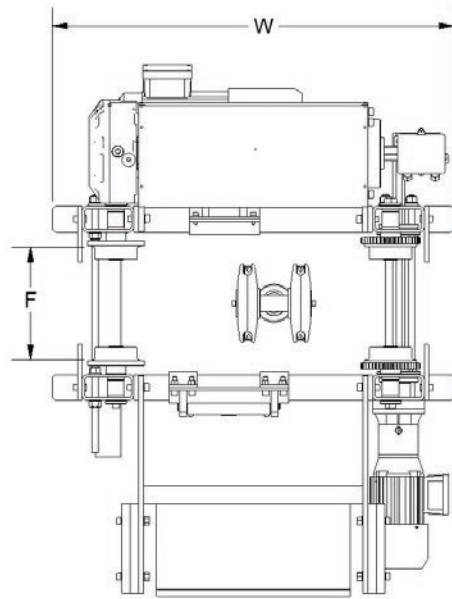

SMW Series Wire Rope Hoist Dimensions

SKU	C	D	F	H	L	R	T	W
SMW0322-30	8 5/8"	21 5/8"	8" Min 25" Max	23" Min	41 1/4" Min 52 7/8" Max	1 1/8"	1 3/4"	42 3/4"
SMW0524-30	9 5/8"	21 5/8"	8" Min 25" Max	24" Min	41 1/2" Min 53 1/4" Max	1 1/4"	2 1/8"	42 3/8"
SMW1021-30	12 1/4"	25 3/8"	8" Min 25" Max	30" Min	48 3/8" Min 67" Max	1 5/8"	2 5/8"	48 1/2"
SMW1521-30	11 3/4"	28 5/16"	8" Min 25" Max	41 7/8" Min	57 1/16" Min 69 7/16" Max	2"	3 3/16"	49 1/8"

# SMW SERIES

## MONORAIL WIRE ROPE HOIST 230V 3-PHASE MODELS



Model	Cap	Lift (ft)	HMI Duty Rating	Flange Range	Lifting Speed	Lifting Motor (HP)	Travel Speed	Trolley Motor (HP)	Weight	List
SMW0322-20-230V-3PH	3 Ton	20'	H4	8" - 20"	22/4 FPM	4	75/20FPM	0.5	765 lbs	\$9,405
SMW0322-30-230V-3PH	3 Ton	30'	H4	8" - 20"	22/4 FPM	4	75/20FPM	0.5	801 lbs	\$9,790
SMW0322-40-230V-3PH	3 Ton	40'	H4	8" - 20"	22/4 FPM	4	75/20FPM	0.5	849 lbs	\$10,176
SMW0524-20-230V-3PH	5 Ton	20'	H4	8" - 25"	24/4 FPM	8	75/20FPM	0.85	911 lbs	\$10,005
SMW0524-30-230V-3PH	5 Ton	30'	H4	8" - 25"	24/4 FPM	8	75/20FPM	0.85	959 lbs	\$10,533
SMW0524-40-230V-3PH	5 Ton	40'	H4	8" - 25"	24/4 FPM	8	75/20FPM	0.85	1,019 lbs	\$11,061
SMW0721-20-230V-3PH	7.5 Ton	20'	H4	8" - 25"	21/4 FPM	15	75/20 FPM	1.3	1,795 lbs	\$20,976
SMW0721-30-230V-3PH	7.5 Ton	30'	H4	8" - 25"	21/4 FPM	15	75/20 FPM	1.3	1,867 lbs	\$21,508
SMW0721-40-230V-3PH	7.5 Ton	40'	H4	8" - 25"	21/4 FPM	15	75/20 FPM	1.3	1,964 lbs	\$22,040
SMW1021-20-230V-3PH	10 Ton	20'	H4	8" - 25"	21/4 FPM	15	75/20 FPM	1.3	1,795 lbs	\$20,976
SMW1021-30-230V-3PH	10 Ton	30'	H4	8" - 25"	21/4 FPM	15	75/20 FPM	1.3	1,867 lbs	\$21,508
SMW1021-40-230V-3PH	10 Ton	40'	H4	8" - 25"	21/4 FPM	15	75/20 FPM	1.3	1,964 lbs	\$22,040



48 Hour Quick Ship | Models Highlighted Above

- Standard voltage for all models listed above is 230V-3 phase.
- All models include Load Cell with 3" LED Display showing Live Load Lbs.
- For additional or custom capacity and lift heights (50', 60', 70', 80'), please contact your distributor.
- Wire rope hoists (7.5 Ton and larger) have VFD controlled lifting and VFD trolley

## Flange Width Adder

SKU	Cap	Flange Range	List
SMW03FW27	3 Ton	20" - 27"	\$2,056
SMW05FW27	5 Ton	25" - 31"	\$2,271
SMW07FW27	7.5 Ton	25" - 31"	\$2,383
SMW10FW27	10 Ton	25" - 31"	\$2,383
SMW15FW27	15 Ton	25" - 31"	\$2,498



**Standard VFD  
Lift & Trolley Motion**  
(7.5 Ton and Greater Capacities)

**VFD TECHNOLOGY**  
FEATURING  
**DANFOSS DRIVES**

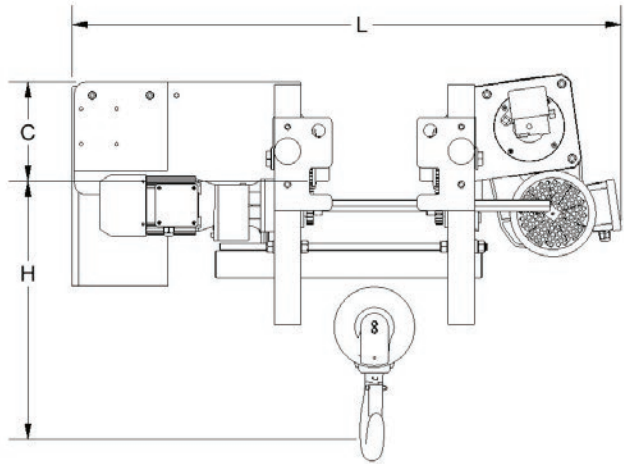
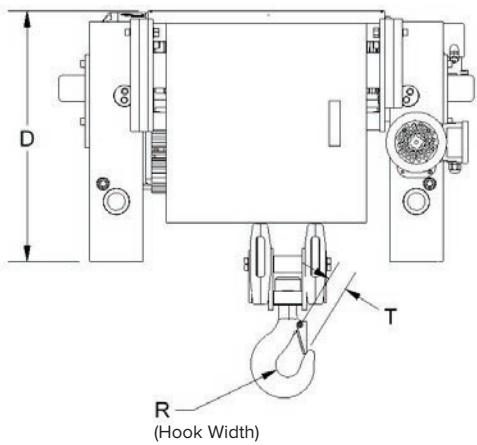
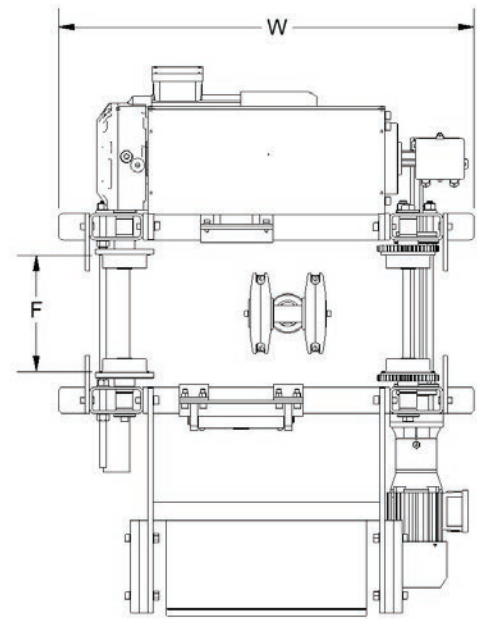

R  
(Hook Width)

SMW Series Wire Rope Hoist Dimensions

SKU	C	D	F	H	L	R	T	W
SMW0322-30	8 5/8"	21 5/8"	8" Min 25" Max	23" Min	41 1/4" Min 52 7/8" Max	1 1/8"	1 3/4"	42 3/4"
SMW0524-30	9 5/8"	21 5/8"	8" Min 25" Max	24" Min	41 1/2" Min 53 1/4" Max	1 1/4"	2 1/8"	42 3/8"
SMW1021-30	12 1/4"	25 3/8"	8" Min 25" Max	30" Min	48 3/8" Min 67" Max	1 5/8"	2 5/8"	48 1/2"
SMW1521-30	11 3/4"	28 5/16"	8" Min 25" Max	41 7/8" Min	57 1/16" Min 69 7/16" Max	2"	3 3/16"	49 1/8"

# STW SERIES

## TOP RUNNING WIRE ROPE HOIST



Model	Capacity	Lift	HMI Duty Rating	Lifting Speed	Lifting Motor (HP)	Travel Speed	Trolley Motor (HP)	Gauge (G)	Weight	List
STW0520-30-460V-60	<b>5 Ton</b>	30'	H4	20/4 FPM	9	75/20 FPM	0.85	60"	1,309 lbs	\$13,656
STW0520-40-460V-60	<b>5 Ton</b>	40'	H4	20/4 FPM	9	75/20 FPM	0.85	60"	1,362 lbs	\$14,145
STW0520-60-460V-78	<b>5 Ton</b>	60'	H4	20/4 FPM	9	75/20 FPM	0.85	78"	1,471 lbs	\$15,349
STW0720-30-460V-60	<b>7.5 Ton</b>	30'	H4	20/4 FPM	13	75/20 FPM	1.3	60"	1,693 lbs	\$22,531
STW0720-40-460V-60	<b>7.5 Ton</b>	40'	H4	20/4 FPM	13	75/20 FPM	1.3	60"	1,743 lbs	\$23,125
STW0720-60-460V-78	<b>7.5 Ton</b>	60'	H4	20/4 FPM	13	75/20 FPM	1.3	78"	1,855 lbs	\$24,314
STW1020-30-460V-60	<b>10 Ton</b>	30'	H4	20/4 FPM	13	75/20 FPM	1.3	60"	1,693 lbs	\$22,531
STW1020-40-460V-60	<b>10 Ton</b>	40'	H4	20/4 FPM	13	75/20 FPM	1.3	60"	1,743 lbs	\$23,125
STW1020-60-460V-78	<b>10 Ton</b>	60'	H4	20/4 FPM	13	75/20 FPM	1.3	78"	1,855 lbs	\$24,314
STW1520-30-460V-78	<b>15 Ton</b>	30'	H4	20/4 FPM	25	75/20 FPM	1.4	78"	2,629 lbs	\$35,306
STW1520-40-460V-78	<b>15 Ton</b>	40'	H4	20/4 FPM	25	75/20 FPM	1.4	78"	2,694 lbs	\$36,002
STW1520-60-460V-94	<b>15 Ton</b>	60'	H4	20/4 FPM	25	75/20 FPM	1.4	94"	2,838 lbs	\$37,394
STW2020-30-460V-78	<b>20 Ton</b>	30'	H4	20/4 FPM	25	75/20 FPM	1.4	78"	2,629 lbs	\$35,306
STW2020-40-460V-78	<b>20 Ton</b>	40'	H4	20/4 FPM	25	75/20 FPM	1.4	78"	2,694 lbs	\$36,002
STW2020-60-460V-94	<b>20 Ton</b>	60'	H4	20/4 FPM	25	75/20 FPM	1.4	94"	2,838 lbs	\$37,394



48 Hour Quick Ship | Models Highlighted Above

- Estimated lead time for non-stock models: 12 Weeks
- Standard voltage for all models listed above is 460V-3 phase.
- For additional or custom capacity, gauge, and lift heights (50', 60', 70', 80'), please contact your distributor.
- All models include Load Cell with 3" LED Display showing Live Load Lbs
- Wire rope hoists (7.5 Ton and larger) have VFD controlled lifting and VFD trolley

### VFD Lift Adder

SKU	Cap	List
STW0520	<b>5 Ton</b>	\$2,100



**Standard VFD**  
**Lift & Trolley Motion**  
 (7.5 Ton and Greater Capacities)

**VFD TECHNOLOGY**  
 FEATURING  
**DANFOSS DRIVES**

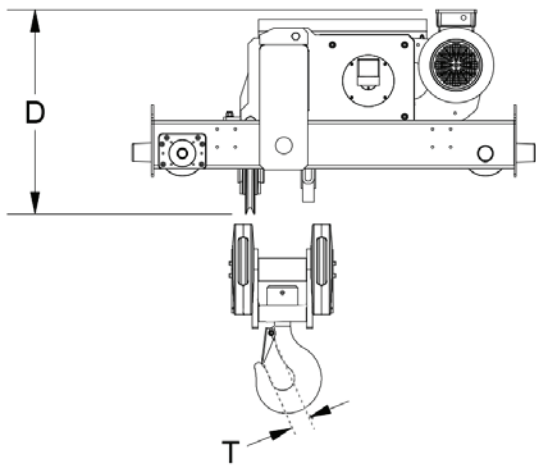
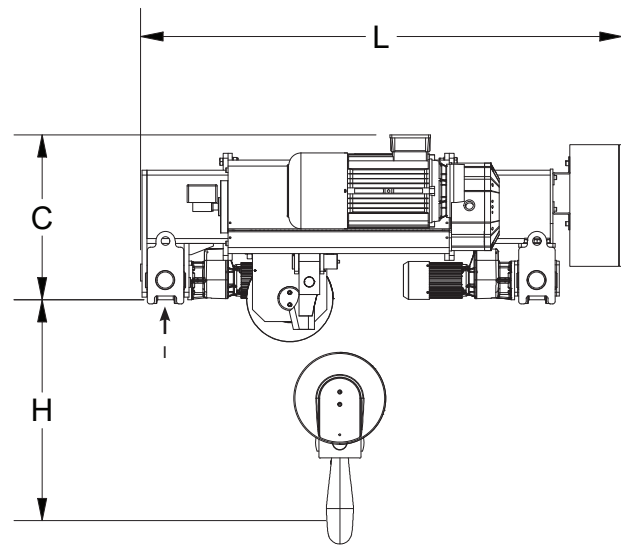
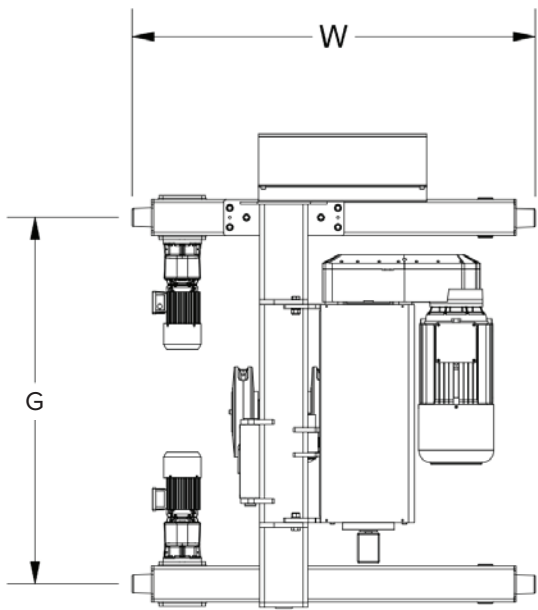

STW Series Wire Rope Hoist Dimensions							
SKU	C	D	I	L	H	T	W
STW0520-30	18 1/2"	21 1/4"	2 9/16"	77 3/16" MIN	36 1/8"	2"	54 3/16"
STW0720-30	21 13/16"	26 1/2"	2 9/16"	77 3/16" MIN	36 1/8"	2 1/4"	54 3/16"
STW1020-30	21 13/16"	26 1/2"	2 9/16"	77 3/16" MIN	36 1/8"	2 1/4"	54 3/16"
STW1520-30	26 5/8"	33 3/8"	3 1/2"	77 11/16" MIN	39"	3"	66"
STW2020-30	26 5/8"	33 3/8"	3 1/2"	77 11/16" MIN	39"	3"	66"

# STW SERIES

## TOP RUNNING WIRE ROPE HOIST

### 230V 3-PHASE MODELS



Model	Cap	Lift	HMI Duty Rating	Lifting Speed	Lifting Motor (HP)	Travel Speed	Trolley Motor (HP)	Gauge (G)	Weight	List
STW0520-30-230V-60	5 Ton	30'	H4	20/4 FPM	9	75/20 FPM	0.85	60"	1,309 lbs	\$12,966
STW0520-40-230V-60	5 Ton	40'	H4	20/4 FPM	9	75/20 FPM	0.85	60"	1,362 lbs	\$13,431
STW0520-60-230V-78	5 Ton	60'	H4	20/4 FPM	9	75/20 FPM	0.85	78"	1,471 lbs	\$14,002
STW0720-30-230V-60	7.5 Ton	30'	H4	20/4 FPM	13	75/20 FPM	1.3	60"	1,693 lbs	\$26,747
STW0720-40-230V-60	7.5 Ton	40'	H4	20/4 FPM	13	75/20 FPM	1.3	60"	1,743 lbs	\$27,312
STW0720-60-230V-78	7.5 Ton	60'	H4	20/4 FPM	13	75/20 FPM	1.3	78"	1,855 lbs	\$28,440
STW1020-30-230V-60	10 Ton	30'	H4	20/4 FPM	13	75/20 FPM	1.3	60"	1,693 lbs	\$26,747
STW1020-40-230V-60	10 Ton	40'	H4	20/4 FPM	13	75/20 FPM	1.3	60"	1,743 lbs	\$27,312
STW1020-60-230V-78	10 Ton	60'	H4	20/4 FPM	13	75/20 FPM	1.3	78"	1,855 lbs	\$28,440



48 Hour Quick Ship | Models Highlighted Above

- Standard voltage for all models listed above is 230V-3 phase.
- For additional or custom capacity, gauge, and lift heights (50', 60', 70', 80'), please contact your distributor.
- All models include Load Cell with 3" LED Display showing Live Load Lbs
- Wire rope hoists (7.5 Ton and larger) have VFD controlled lifting and VFD trolley



**Standard VFD  
Lift & Trolley Motion**  
(7.5 Ton and Greater Capacities)

**VFD TECHNOLOGY** FEATURING  
**DANFOSS DRIVES**

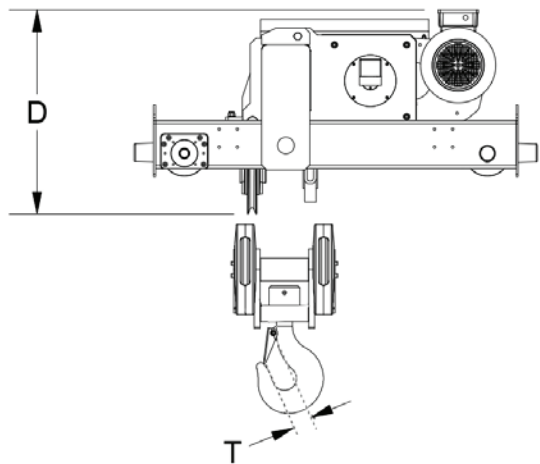
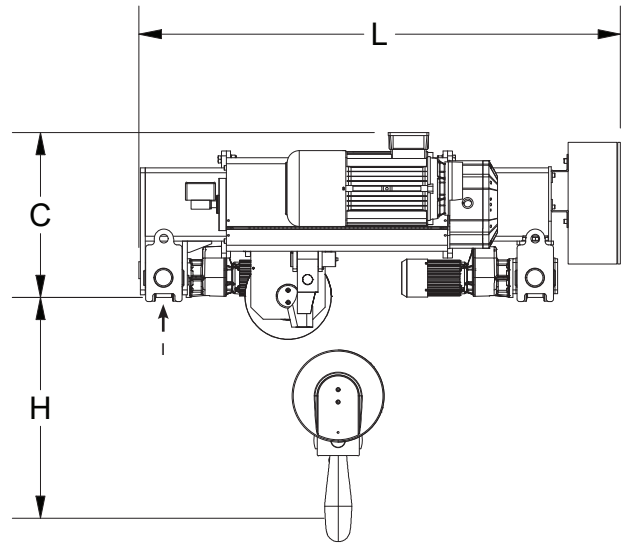
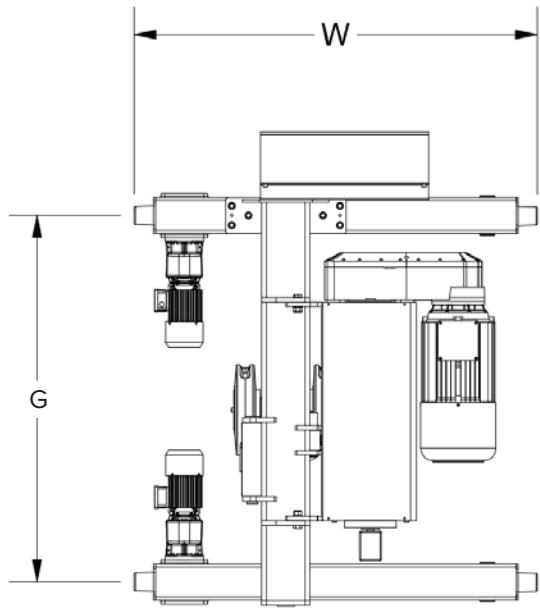

STW Series Wire Rope Hoist Dimensions							
SKU	C	D	I	L	H	T	W
STW0520-30	18 1/2"	21 1/4"	2 9/16"	77 3/16" MIN	36 1/8"	2"	54 3/16"
STW0720-30	21 13/16"	26 1/2"	2 9/16"	77 3/16" MIN	36 1/8"	2 1/4"	54 3/16"
STW1020-30	21 13/16"	26 1/2"	2 9/16"	77 3/16" MIN	36 1/8"	2 1/4"	54 3/16"
STW1520-30	26 5/8"	33 3/8"	3 1/2"	77 11/16" MIN	35 11/16"	3"	66"
STW2020-30	26 5/8"	33 3/8"	3 1/2"	77 11/16" MIN	35 11/16"	3"	66"

# STW SERIES

## HIGH CAPACITY TOP RUNNING WIRE ROPE HOIST



### All High Capacity Models Come Standard With True Vertical Lift

Model	Cap	Lift	HMI Duty Rating	Lifting Speed	Lifting Motor (HP)	Travel Speed	Trolley Motor (HP)	Gauge (G)	Weight	List
STW2511-30-460V-108	<b>25 Ton</b>	30'	H4	11/2.5 FPM	27	65/16 FPM	2.5	108"	3700 lbs	\$45,998
STW2511-40-460V-108	<b>25 Ton</b>	40'	H4	11/2.5 FPM	27	65/16 FPM	2.5	108"	3800 lbs	\$47,025
STW2511-50-460V-122	<b>25 Ton</b>	50'	H4	11/2.5 FPM	27	65/16 FPM	2.5	122"	3900 lbs	\$48,052
STW2511-60-460V-138	<b>25 Ton</b>	60'	H4	11/2.5 FPM	27	65/16 FPM	2.5	134"	4000 lbs	\$49,079
STW3011-30-460V-108	<b>30 Ton</b>	30'	H4	11/2.5 FPM	51	65/16 FPM	2.5	108"	4100 lbs	\$47,554
STW3011-40-460V-108	<b>30 Ton</b>	40'	H4	11/2.5 FPM	51	65/16 FPM	2.5	108"	4200 lbs	\$48,581
STW3011-50-460V-122	<b>30 Ton</b>	50'	H4	11/2.5 FPM	51	65/16 FPM	2.5	122"	4300 lbs	\$49,608
STW3011-60-460V-138	<b>30 Ton</b>	60'	H4	11/2.5 FPM	51	65/16 FPM	2.5	134"	4400 lbs	\$50,635
STW4016-30-460V-84	<b>40 Ton</b>	30'	H4	15/2.5 FPM	51	65/16 FPM	3.5	84"	5500 lbs	\$70,647
STW4016-40-460V-96	<b>40 Ton</b>	40'	H4	15/2.5 FPM	51	65/16 FPM	3.5	96"	5600 lbs	\$71,892
STW4016-50-460V-108	<b>40 Ton</b>	50'	H4	15/2.5 FPM	51	65/16 FPM	3.5	108"	5700 lbs	\$73,137
STW4016-60-460V-108	<b>40 Ton</b>	60'	H4	15/2.5 FPM	51	65/16 FPM	3.5	108"	5800 lbs	\$74,382
STW5011-30-460V-108	<b>50 Ton</b>	30'	H4	11/2.5 FPM	51	65/16 FPM	3.5	108"	7500 lbs	\$74,786
STW5011-40-460V-108	<b>50 Ton</b>	40'	H4	11/2.5 FPM	51	65/16 FPM	3.5	108"	7700 lbs	\$76,436
STW5011-50-460V-138	<b>50 Ton</b>	50'	H4	11/2.5 FPM	51	65/16 FPM	3.5	122"	7900 lbs	\$78,085
STW5011-60-460V-150	<b>50 Ton</b>	60'	H4	11/2.5 FPM	51	65/16 FPM	3.5	150"	8100 lbs	\$79,735

- Standard voltage for all models listed above is 460V-3 phase.
- All models include Load Cell with 3" LED Display showing Live Load Lbs
- All models have VFD controlled lifting and VFD trolley



**Standard VFD  
Lift & Trolley Motion**  
(7.5 Ton and Greater Capacities)

**VFD TECHNOLOGY**  
FEATURING  
**DANFOSS DRIVES**

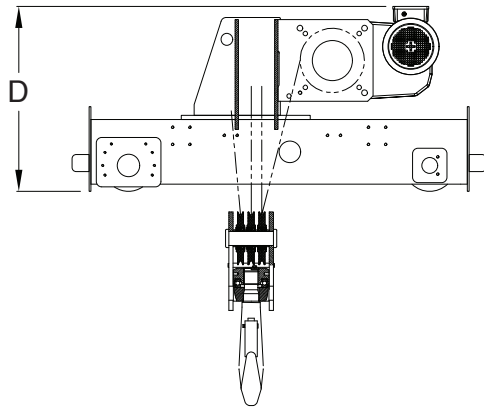
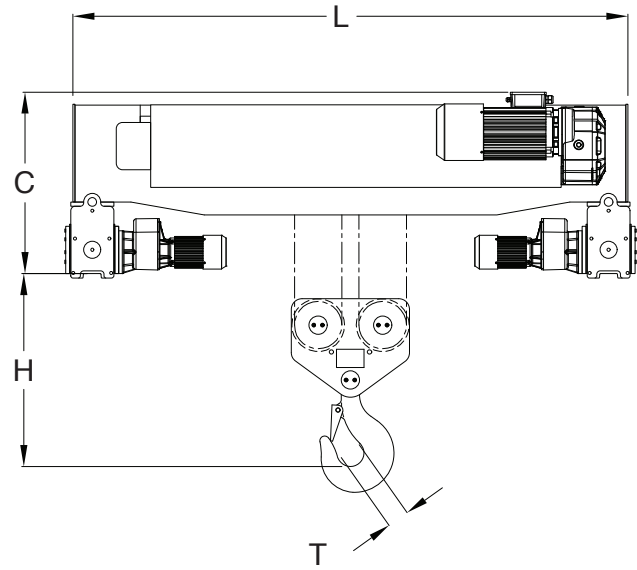
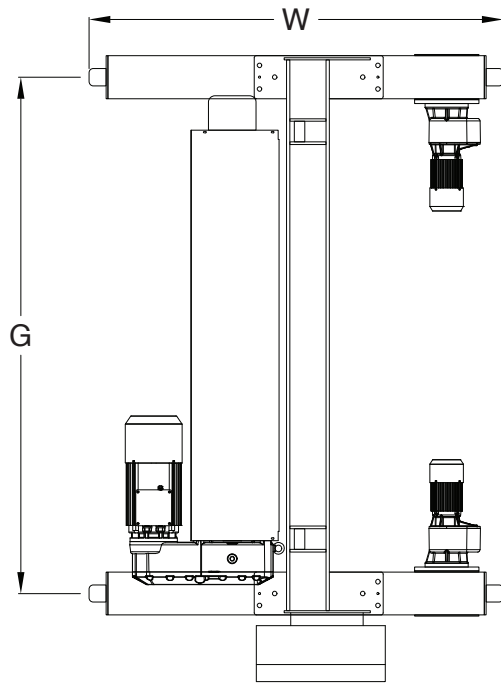

STW Series (High Capacity) Wire Rope Hoist Dimensions					
SKU	MIN GA	L	W	H	C
STW2511-30	108"	112 ¼"	73"	24 ½"	34 ¼"
STW3011-30	108"	112 ¼"	73"	24 ½"	34 ¼"
STW4016-30	84"	104 ½"	84 ¼"	38 ½"	40 ¾"
STW5011-30	108"	120"	82 ½"	38 ½"	40 ¾"

# SMW & STW WIRE ROPE HOIST FEATURES



## Precision Lift Gear Box

The gear box is a three stage oil bath, precision geared, and sealed with cast-aluminum covers designed for great heat dissipation and easy maintenance.



## Load Cell with LED Display

All SMW & STW models come standard with a load cell on the wire rope dead end connection that displays live load weight at all times. The 3" display lets the operator know at a glance how many pounds the system is carrying. This adds safety for the operator, longevity of the hoist, and provides the ability to calculate load weights for freight companies.

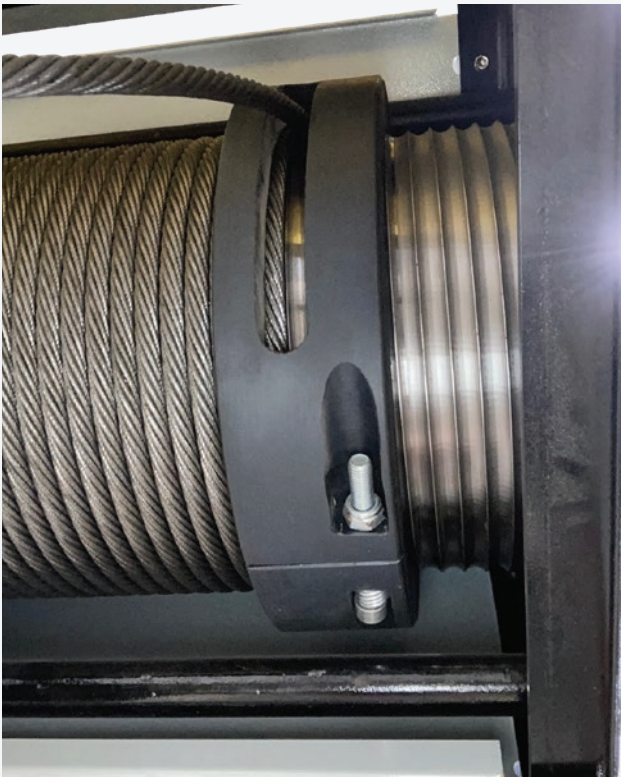

## Wire Rope Drum Guide

The rope drum is deeply grooved with high quality seamless steel tube and a high tensile rope guide for optimum line arrangement, greater safety factor, and longer life.



## Efficient Lifting Motor

Hoists feature a heavy duty lifting motor designed for long component life and ease of routine service.



## Travel Limit Control

For additional safety, this hoist comes standard with built in travel limit controls for both up and down travel operation.



### 3 & 5 Ton Hoist Panel

High quality NEMA 35 control panel. Includes phase protection, motor overheating protection, as well as transformer circuit fuse protection. Includes Danfoss VLT Microdrive to control trolley travel speed allowing adjustable smooth ramp-up options.



**VLT  
Micro Drive**

**VFD TECHNOLOGY**  
FEATURING  
**DANFOSS DRIVES**

- VFD Controlled Lift
- VFD Controlled Trolley Motion
- Improves Load Control
- Infinitely Adjustable Ramp Up & Down Control of Lift and Trolley Motion



### HD Hook Block

Robust all-metal lower hook assembly designed for many years of operation even in tough environments. Includes easy to remove covers for maintenance and wire rope replacement. The Hook is designed to freely swivel 360 degrees for convenient load attachment.



### Optional Pendant Control

Quality 2-Speed pendant control with E-Stop. Select 2-Motion for monorail applications and 3-Motion when the hoist is paired with a bridge crane.

# ASCE RAIL SPECS

Rail Type	Suggested Bridge Capacity	Recommended Endtrucks	Height (A)	Base Width (B)	Head Width (C)
#30	3T - 5T	STT-130 Series	3 1/8"	3 1/8"	1 11/16"
#30	5T - 10T	STT-170 Series	3 1/8"	3 1/8"	1 11/16"
#40	10T - 15T	STT-250 Series	3 1/2"	3 1/2"	1 7/8"
#60	15T - 25T	STT-300 Series	4 1/4"	4 1/4"	2 3/8"

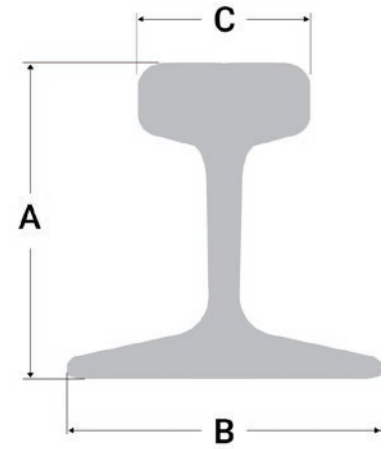

## Crane Rail Max Wheel Loading

STT End Truck Wheel Specs			ASCE Crane Rail Size			
Wheel Diameter		Wheel Hardness	25#	30#	40#	60#
mm	in.	BHN (Brinell Hardness Number)	Wheel Loading (lbs)			
130	5.12	420	7,136	7,136		
170	6.69	420	10,800	10,800	10,800	
250	9.84	420		18,400	18,400	18,400
300	11.81	420		21,700	25,489	28,000

# CRANE COMPONENTS

## Top-Running "STT" Series Motorized Fixed Axle End Trucks Designed for ASCE Rail Runways

### Model Number Chart

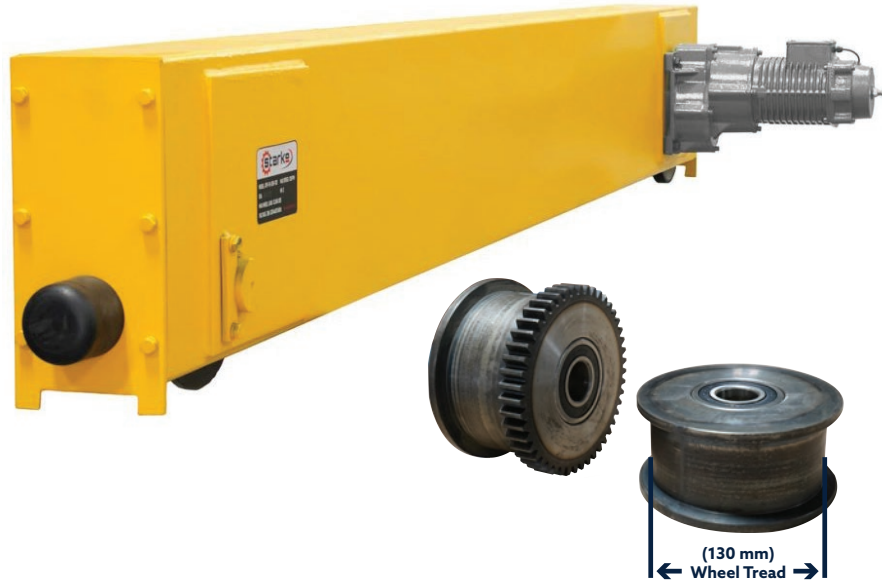
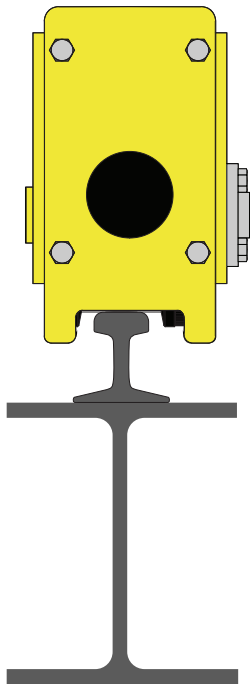
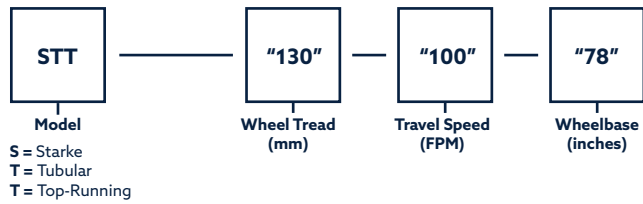

### 3 Ton Capacities

SKU	Cap	Speed	Wheel Tread	Wheel Base (in.)	Max Bridge Span (ft.)	Voltage	HP	Amp @ 230/460 (One Motor)	Motor Rating	Bearing Life (Hrs)	MAX Wheel Loading	Total Weight Set	List
STT-130-100-42	1-3 Ton	100 FPM	5.12" (130mm)	42"	28'	230/460	1	5.2/2.6	H4	10,000	7,600 lbs	490 lbs	\$3,523
STT-130-100-48	1-3 Ton	100 FPM	5.12" (130mm)	48"	32'	230/460	1	5.2/2.6	H4	10,000	7,600 lbs	512 lbs	\$3,744
STT-130-100-54	1-3 Ton	100 FPM	5.12" (130mm)	54"	36'	230/460	1	5.2/2.6	H4	10,000	7,600 lbs	535 lbs	\$3,965
STT-130-100-60	1-3 Ton	100 FPM	5.12" (130mm)	60"	40'	230/460	1	5.2/2.6	H4	10,000	7,600 lbs	557 lbs	\$4,186
STT-130-100-66	1-3 Ton	100 FPM	5.12" (130mm)	66"	44'	230/460	1	5.2/2.6	H4	10,000	7,600 lbs	580 lbs	\$4,407
STT-130-100-72	1-3 Ton	100 FPM	5.12" (130mm)	72"	48'	230/460	1	5.2/2.6	H4	10,000	7,600 lbs	602 lbs	\$4,627
STT-130-100-78	1-3 Ton	100 FPM	5.12" (130mm)	78"	52'	230/460	1	5.2/2.6	H4	10,000	7,600 lbs	624 lbs	\$4,848
STT-130-100-84	1-3 Ton	100 FPM	5.12" (130mm)	84"	56'	230/460	1	5.2/2.6	H4	10,000	7,600 lbs	647 lbs	\$5,069
STT-130-100-90	1-3 Ton	100 FPM	5.12" (130mm)	90"	60'	230/460	1	5.2/2.6	H4	10,000	7,600 lbs	669 lbs	\$5,290
STT-130-100-96	1-3 Ton	100 FPM	5.12" (130mm)	96"	64'	230/460	1	5.2/2.6	H4	10,000	7,600 lbs	692 lbs	\$5,510

- All end truck sets ship prime painted gray
- End truck wheel base should be your bridge length in inches divided by 8
- Motor includes holding brake
- Price includes seat plates and hardware
- STT-130 & STT-170 capable of single phase (230V Only)

## Top-Running "STT" Series Motorized End Trucks 5 Ton - 10 Ton Capacities

Top-Running Series - Standard Wheel Base Models													
STT-170-150-48	5 Ton	150 FPM	6.69" (170mm)	48"	32'	230/460	1.5	7.8/3.9	H4	10,000	12,500 lbs	625 lbs	\$5,210
STT-170-150-54	5 Ton	150 FPM	6.69" (170mm)	54"	36'	230/460	1.5	7.8/3.9	H4	10,000	12,500 lbs	657 lbs	\$5,387
STT-170-150-60	5 Ton	150 FPM	6.69" (170mm)	60"	40'	230/460	1.5	7.8/3.9	H4	10,000	12,500 lbs	688 lbs	\$5,563
STT-170-150-66	5 Ton	150 FPM	6.69" (170mm)	66"	44'	230/460	1.5	7.8/3.9	H4	10,000	12,500 lbs	720 lbs	\$5,740
STT-170-150-72	5 Ton	150 FPM	6.69" (170mm)	72"	48'	230/460	1.5	7.8/3.9	H4	10,000	12,500 lbs	752 lbs	\$5,917
STT-170-150-78	5 Ton	150 FPM	6.69" (170mm)	78"	52'	230/460	1.5	7.8/3.9	H4	10,000	12,500 lbs	784 lbs	\$6,093
STT-170-150-84	5 Ton	150 FPM	6.69" (170mm)	84"	56'	230/460	1.5	7.8/3.9	H4	10,000	12,500 lbs	816 lbs	\$6,270
STT-170-150-90	5 Ton	150 FPM	6.69" (170mm)	90"	60'	230/460	1.5	7.8/3.9	H4	10,000	12,500 lbs	848 lbs	\$6,446
STT-170-150-96	5 Ton	150 FPM	6.69" (170mm)	96"	64'	230/460	1.5	7.8/3.9	H4	10,000	12,500 lbs	880 lbs	\$7,506
STT-170-150-102	5 Ton	150 FPM	6.69" (170mm)	102"	68'	230/460	1.5	7.8/3.9	H4	10,000	12,500 lbs	911 lbs	\$6,800
STT-170-150-108	5 Ton	150 FPM	6.69" (170mm)	108"	72'	230/460	1.5	7.8/3.9	H4	10,000	12,500 lbs	943 lbs	\$6,976
STT-170-150-114	5 Ton	150 FPM	6.69" (170mm)	114"	76'	230/460	1.5	7.8/3.9	H4	10,000	12,500 lbs	975 lbs	\$7,153
STT-170-150-120	5 Ton	150 FPM	6.69" (170mm)	120"	80'	230/460	1.5	7.8/3.9	H4	10,000	12,500 lbs	1,007 lbs	\$7,330
STT-170-150-126	5 Ton	150 FPM	6.69" (170mm)	126"	84'	230/460	1.5	7.8/3.9	H4	10,000	12,500 lbs	1,039 lbs	\$7,957
STT-250-150-54	10 Ton	150 FPM	9.84" (250mm)	54"	36'	230/460	2	10/5	H4	10,000	18,400 lbs	1,281 lbs	\$8,241
STT-250-150-60	10 Ton	150 FPM	9.84" (250mm)	60"	40'	230/460	2	10/5	H4	10,000	18,400 lbs	1,330 lbs	\$8,294
STT-250-150-72	10 Ton	150 FPM	9.84" (250mm)	72"	48'	230/460	2	10/5	H4	10,000	18,400 lbs	1,379 lbs	\$8,347
STT-250-150-78	10 Ton	150 FPM	9.84" (250mm)	78"	52'	230/460	2	10/5	H4	10,000	18,400 lbs	1,427 lbs	\$8,400
STT-250-150-84	10 Ton	150 FPM	9.84" (250mm)	84"	56'	230/460	2	10/5	H4	10,000	18,400 lbs	1,476 lbs	\$8,454
STT-250-150-90	10 Ton	150 FPM	9.84" (250mm)	90"	60'	230/460	2	10/5	H4	10,000	18,400 lbs	1,525 lbs	\$8,507
STT-250-150-96	10 Ton	150 FPM	9.84" (250mm)	96"	64'	230/460	2	10/5	H4	10,000	18,400 lbs	1,574 lbs	\$8,560
STT-250-150-102	10 Ton	150 FPM	9.84" (250mm)	102"	68'	230/460	2	10/5	H4	10,000	18,400 lbs	1,623 lbs	\$8,613
STT-250-150-108	10 Ton	150 FPM	9.84" (250mm)	108"	72'	230/460	2	10/5	H4	10,000	18,400 lbs	1,672 lbs	\$8,667
STT-250-150-114	10 Ton	150 FPM	9.84" (250mm)	114"	76'	230/460	2	10/5	H4	10,000	18,400 lbs	1,721 lbs	\$8,720
STT-250-150-120	10 Ton	150 FPM	9.84" (250mm)	120"	80'	230/460	2	10/5	H4	10,000	18,400 lbs	1,770 lbs	\$8,773
STT-250-150-126	10 Ton	150 FPM	9.84" (250mm)	126"	84'	230/460	2	10/5	H4	10,000	18,400 lbs	1,818 lbs	\$8,826

**Top-Running "STT" Series  
Motorized End Trucks**  
**10 Ton - 15 Ton Capacities**

HOISTS

CRANE COMPONENTS

ELECTRIFICATION & CONTROLS

CRANE KITS

SLINGS

SAFETY

Top-Running Series - Standard Wheel Base Models													
STT-250-150-132	10 Ton	150 FPM	9.84" (250mm)	132"	88'	230/460	2	10/5	H4	10,000	18,400 lbs	1,867 lbs	\$8,880
STT-250-150-138	10 Ton	150 FPM	9.84" (250mm)	138"	92'	230/460	2	10/5	H4	10,000	18,400 lbs	1,916 lbs	\$8,933
STT-250-150-144	10 Ton	150 FPM	9.84" (250mm)	144"	96'	230/460	2	10/5	H4	10,000	18,400 lbs	1,965 lbs	\$8,986
STT-250-150-150	10 Ton	150 FPM	9.84" (250mm)	150"	100'	230/460	2	10/5	H4	10,000	18,400 lbs	2,014 lbs	\$9,139
STT-300-200-60	15 Ton	200 FPM	11.81" (300mm)	60"	40'	230/460	5	16.3/8.1	H4	10,000	31,000 lbs	1,822 lbs	\$11,371
STT-300-200-66	15 Ton	200 FPM	11.81" (300mm)	66"	44'	230/460	5	16.3/8.1	H4	10,000	31,000 lbs	1,880 lbs	\$11,673
STT-300-200-78	15 Ton	200 FPM	11.81" (300mm)	78"	52'	230/460	5	16.3/8.1	H4	10,000	31,000 lbs	1,939 lbs	\$11,974
STT-300-200-84	15 Ton	200 FPM	11.81" (300mm)	84"	56'	230/460	5	16.3/8.1	H4	10,000	31,000 lbs	1,997 lbs	\$12,276
STT-300-200-90	15 Ton	200 FPM	11.81" (300mm)	90"	60'	230/460	5	16.3/8.1	H4	10,000	31,000 lbs	2,055 lbs	\$12,578
STT-300-200-96	15 Ton	200 FPM	11.81" (300mm)	96"	64'	230/460	5	16.3/8.1	H4	10,000	31,000 lbs	2,113 lbs	\$12,879
STT-300-200-102	15 Ton	200 FPM	11.81" (300mm)	102"	68'	230/460	5	16.3/8.1	H4	10,000	31,000 lbs	2,171 lbs	\$13,181
STT-300-200-108	15 Ton	200 FPM	11.81" (300mm)	108"	72'	230/460	5	16.3/8.1	H4	10,000	31,000 lbs	2,229 lbs	\$13,483
STT-300-200-114	15 Ton	200 FPM	11.81" (300mm)	114"	76'	230/460	5	16.3/8.1	H4	10,000	31,000 lbs	2,287 lbs	\$13,784
STT-300-200-120	15 Ton	200 FPM	11.81" (300mm)	120"	80'	230/460	5	16.3/8.1	H4	10,000	31,000 lbs	2,345 lbs	\$14,086
STT-300-200-126	15 Ton	200 FPM	11.81" (300mm)	126"	84'	230/460	5	16.3/8.1	H4	10,000	31,000 lbs	2,403 lbs	\$14,388
STT-300-200-132	15 Ton	200 FPM	11.81" (300mm)	132"	88'	230/460	5	16.3/8.1	H4	10,000	31,000 lbs	2,461 lbs	\$14,689
STT-300-200-138	15 Ton	200 FPM	11.81" (300mm)	138"	92'	230/460	5	16.3/8.1	H4	10,000	31,000 lbs	2,520 lbs	\$14,991
STT-300-200-144	15 Ton	200 FPM	11.81" (300mm)	144"	96'	230/460	5	16.3/8.1	H4	10,000	31,000 lbs	2,578 lbs	\$15,293
STT-300-200-150	15 Ton	200 FPM	11.81" (300mm)	150"	100'	230/460	5	16.3/8.1	H4	10,000	31,000 lbs	2,636 lbs	\$15,594
STT-300-200-156	15 Ton	200 FPM	11.81" (300mm)	156"	104'	230/460	5	16.3/8.1	H4	10,000	31,000 lbs	2,694 lbs	\$15,896
STT-300-200-162	15 Ton	200 FPM	11.81" (300mm)	162"	108'	230/460	5	16.3/8.1	H4	10,000	31,000 lbs	2,752 lbs	\$16,198
STT-300-200-168	15 Ton	200 FPM	11.81" (300mm)	168"	112'	230/460	5	16.3/8.1	H4	10,000	31,000 lbs	2,810 lbs	\$16,499
STT-300-200-174	15 Ton	200 FPM	11.81" (300mm)	174"	116'	230/460	5	16.3/8.1	H4	10,000	31,000 lbs	2,868 lbs	\$16,801
STT-300-200-180	15 Ton	200 FPM	11.81" (300mm)	180"	120'	230/460	5	16.3/8.1	H4	10,000	31,000 lbs	2,926 lbs	\$17,103
STT-300-200-186	15 Ton	200 FPM	11.81" (300mm)	186"	124'	230/460	5	16.3/8.1	H4	10,000	31,000 lbs	2,984 lbs	\$17,404
STT-300-200-192	15 Ton	200 FPM	11.81" (300mm)	192"	128'	230/460	5	16.3/8.1	H4	10,000	31,000 lbs	3,042 lbs	\$17,706

## Top-Running "STT" Series Motorized End Trucks

### 25 Ton Capacities

Top-Running Series - Standard Wheel Base Models													
STT-500-100-108	25 Ton	100 FPM	20" (500mm)	108"	61'	230/460	5	26/13	H4	10,000	55,000 lbs	3,496 lbs	\$17,561
STT-500-100-114	25 Ton	100 FPM	20" (500mm)	114"	64'	230/460	5	26/13	H4	10,000	55,000 lbs	3,682 lbs	\$18,480
STT-500-100-120	25 Ton	100 FPM	20" (500mm)	120"	70'	230/460	5	26/13	H4	10,000	55,000 lbs	3,727 lbs	\$19,399
STT-500-100-126	25 Ton	100 FPM	20" (500mm)	126"	73'	230/460	5	26/13	H4	10,000	55,000 lbs	3,772 lbs	\$20,318
STT-500-100-132	25 Ton	100 FPM	20" (500mm)	132"	77'	230/460	5	26/13	H4	10,000	55,000 lbs	3,817 lbs	\$21,236
STT-500-100-138	25 Ton	100 FPM	20" (500mm)	138"	80'	230/460	5	26/13	H4	10,000	55,000 lbs	3,862 lbs	\$22,155
STT-500-100-144	25 Ton	100 FPM	20" (500mm)	144"	84'	230/460	5	26/13	H4	10,000	55,000 lbs	3,907 lbs	\$23,074
STT-500-100-150	25 Ton	100 FPM	20" (500mm)	150"	87'	230/460	5	26/13	H4	10,000	55,000 lbs	3,952 lbs	\$23,993
STT-500-100-156	25 Ton	100 FPM	20" (500mm)	156"	91'	230/460	5	26/13	H4	10,000	55,000 lbs	3,997 lbs	\$24,911
STT-500-100-162	25 Ton	100 FPM	20" (500mm)	162"	94'	230/460	5	26/13	H4	10,000	55,000 lbs	4,042 lbs	\$25,830
STT-500-100-168	25 Ton	100 FPM	20" (500mm)	168"	98'	230/460	5	26/13	H4	10,000	55,000 lbs	4,087 lbs	\$26,749
STT-500-100-174	25 Ton	100 FPM	20" (500mm)	174"	101'	230/460	5	26/13	H4	10,000	55,000 lbs	4,132 lbs	\$27,668
STT-500-100-180	25 Ton	100 FPM	20" (500mm)	180"	105'	230/460	5	26/13	H4	10,000	55,000 lbs	4,177 lbs	\$28,586
STT-500-100-186	25 Ton	100 FPM	20" (500mm)	186"	108'	230/460	5	26/13	H4	10,000	55,000 lbs	4,222 lbs	\$29,505
STT-500-100-192	25 Ton	100 FPM	20" (500mm)	192"	112'	230/460	5	26/13	H4	10,000	55,000 lbs	4,286 lbs	\$30,424

- All end truck sets prime painted gray
- End truck wheel base should be your bridge length in inches divided by 8
- Motor includes holding brake
- Price includes seat plates and hardware

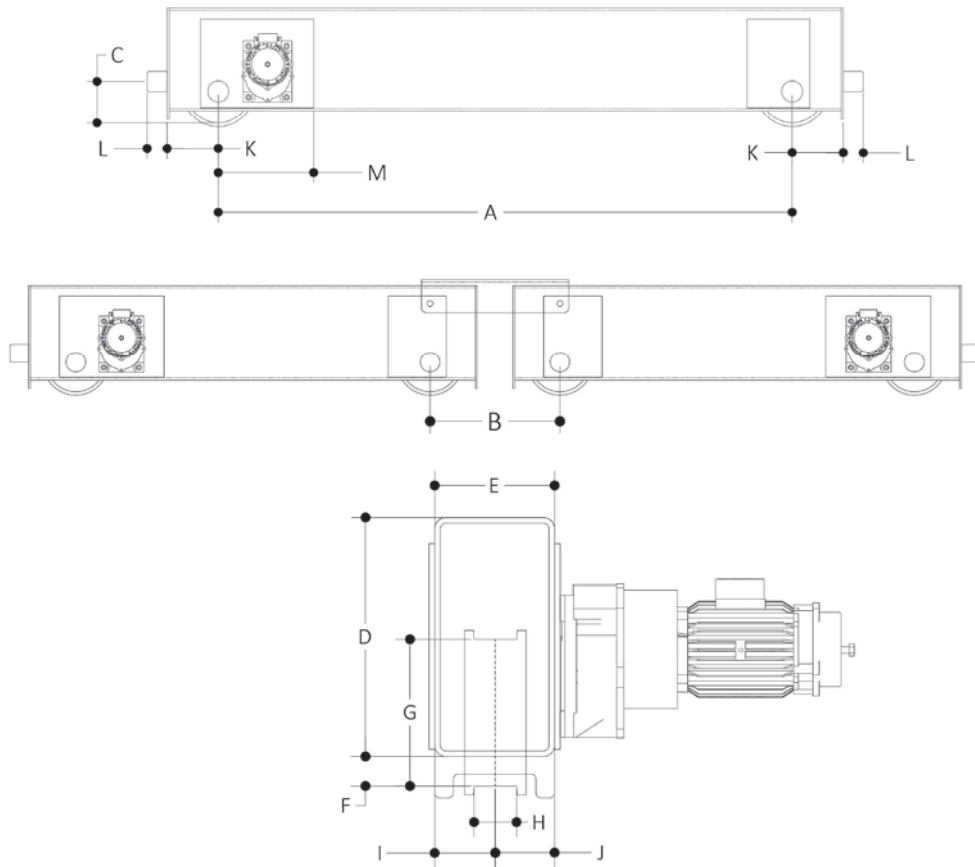

STT Dimensions														
STT mm	A min	A max	B min	C	D	E	F	G	H	I	J	K	L	M
<b>130</b>	42"	72"	13"	3.34"	7.87"	5.90"	.78"	5.12"	1.96"	2.95"	2.95"	5"	2.18"	7.55"
<b>170</b>	48"	126"	15"	3.54"	9.84"	5.90"	1"	6.69"	2.76"	2.65"	3.24"	6"	2.18"	9.05"
<b>250</b>	54"	150"	19"	6.29"	11.81"	7.87"	1.96"	9.84"	2.76"	3.93"	3.93"	8"	3.12"	15.15"
<b>300</b>	60"	150"	23"	6.29"	15.74"	7.87"	1.96"	11.81"	3.14"	3.93"	3.93"	10"	3.12"	16.45"
	138"	192"	23"	6.29"	20"	8"	1.96"	11.81"	3.14"	4"	4"	10"	3.12"	16.45"
<b>500</b>	66"	192"	31"	8.07"	24"	11"	1.96"	19.68"	3.54"	5.11"	5.89"	14"	4.72"	16"
	192"	228"	31"	8.07"	30"	11"	1.96"	19.68"	3.54"	5.11"	5.89"	14"	4.72"	16"

# Top Runner "SCT" Series Motorized End Truck Set Designed for WF Beam

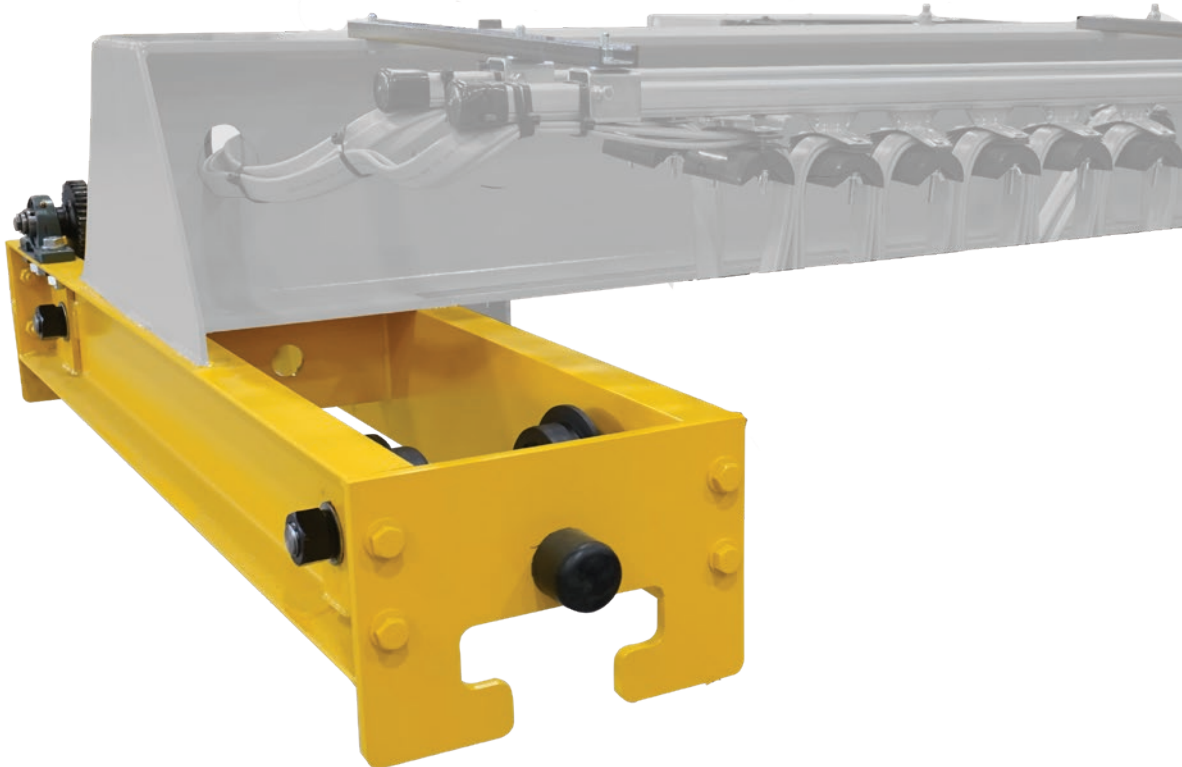
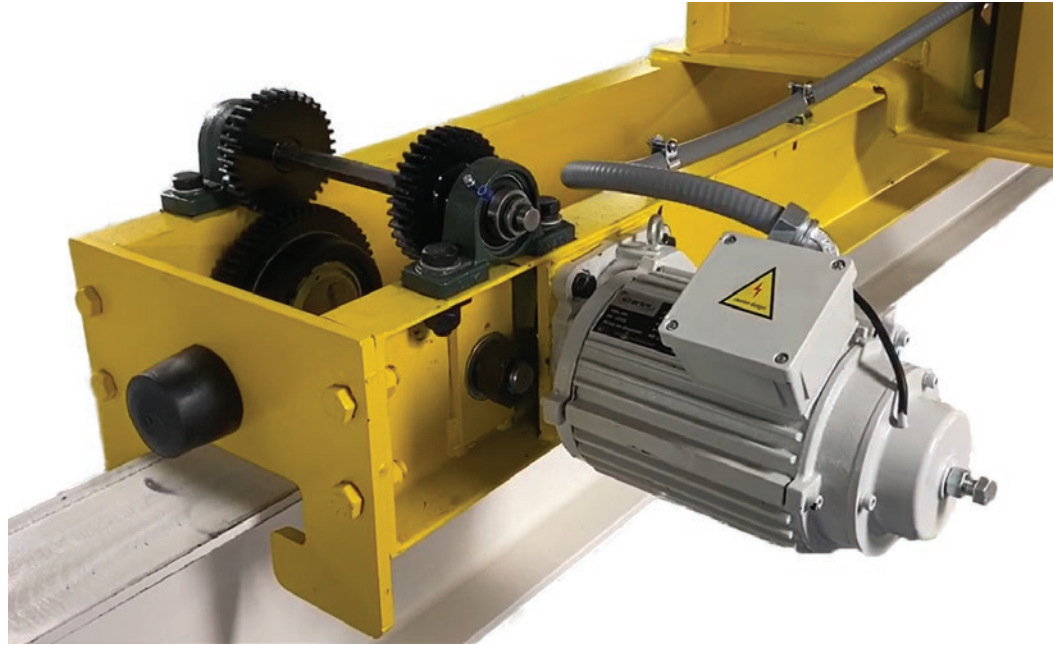
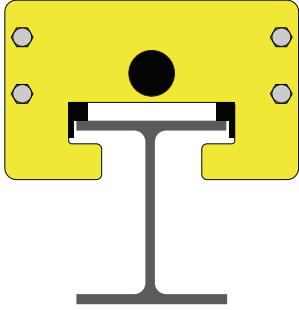

## Model Number Chart



Model      Wheel Tread (mm)      Travel Speed (FPM)      Wheelbase (inches)

S = Starke  
C = Channel  
T = Top-Runner

# Top Runner "SCT" Series Motorized End Truck Set

## 1 - 2 Ton Capacities

SKU	Cap	Speed	Wheel Tread	Wheel Base	Max Span	Voltage	HP	Amp @ 230/460 (One Motor)	Motor Rating	Bearing Life (Hrs)	MAX Wheel Loading (Pair)	Net Weight	List
SCT-110-100-42	1-2 Ton	100 FPM	4.33" (110mm)	42"	28'	230/460	0.5	3.6/1.8	H4	10,000	5,100 lbs	394 lbs	\$4,343
SCT-110-100-48	1-2 Ton	100 FPM	4.33" (110mm)	48"	32'	230/460	0.5	3.6/1.8	H4	10,000	5,100lbs	411 lbs	\$4,385
SCT-110-100-54	1-2 Ton	100 FPM	4.33" (110mm)	54"	36'	230/460	0.5	3.6/1.8	H4	10,000	5,100 lbs	429 lbs	\$4,427
SCT-110-100-60	1-2 Ton	100 FPM	4.33" (110mm)	60"	40'	230/460	0.5	3.6/1.8	H4	10,000	5,100lbs	446 lbs	\$4,469
SCT-110-100-66	1-2 Ton	100 FPM	4.33" (110mm)	66"	44'	230/460	0.5	3.6/1.8	H4	10,000	5,100 lbs	465 lbs	\$4,511
SCT-110-100-72	1-2 Ton	100 FPM	4.33" (110mm)	72"	48'	230/460	0.5	3.6/1.8	H4	10,000	5,100lbs	533 lbs	\$4,553
SCT-110-100-78	1-2 Ton	100 FPM	4.33" (110mm)	78"	52'	230/460	0.5	3.6/1.8	H4	10,000	5,100 lbs	554 lbs	\$4,595

- This model is designed to run directly on top of WF Beam without using ASCE Rail and is generally recommended for Class C or less
- **End user to specify actual flange width of runway beam.**
- Standard available width range: 4"- 10"
- All end truck sets ship prime painted gray
- End truck wheel base should be your bridge length in inches divided by 8
- Motor includes holding brake

## 2 - 3 Ton Capacities

SKU	Cap	Speed	Wheel Tread	Wheel Base	Max Span	Voltage	HP	Amp @ 230/460 (One Motor)	Motor Rating	Bearing Life (Hrs)	MAX Wheel Loading (Pair)	Net Weight	List
SCT-130-100-48	2-3 Ton	100 FPM	5.12" (130mm)	48"	32'	230/460	1	5.2/2.6	H4	10,000	8,500 lbs	563 lbs	\$5,848
SCT-130-100-54	2-3 Ton	100 FPM	5.12" (130mm)	54"	36'	230/460	1	5.2/2.6	H4	10,000	8,500 lbs	587 lbs	\$5,897
SCT-130-100-60	2-3 Ton	100 FPM	5.12" (130mm)	60"	40'	230/460	1	5.2/2.6	H4	10,000	8,500 lbs	611 lbs	\$5,945
SCT-130-100-66	2-3 Ton	100 FPM	5.12" (130mm)	66"	44'	230/460	1	5.2/2.6	H4	10,000	8,500 lbs	636lbs	\$5,993
SCT-130-100-72	2-3 Ton	100 FPM	5.12" (130mm)	72"	48'	230/460	1	5.2/2.6	H4	10,000	8,500 lbs	730 lbs	\$6,041
SCT-130-100-78	2-3 Ton	100 FPM	5.12" (130mm)	78"	52'	230/460	1	5.2/2.6	H4	10,000	8,500 lbs	759 lbs	\$6,089
SCT-130-100-84	2-3 Ton	100 FPM	5.12" (130mm)	84"	56'	230/460	1	5.2/2.6	H4	10,000	8,500 lbs	788 lbs	\$6,137

- This model is designed to run directly on top of WF Beam without using ASCE Rail and is generally recommended for Class C or less
- **End user to specify actual flange width of runway beam.**
- Standard available width range: 4"- 10"
- All end truck sets ship prime painted gray
- End truck wheel base should be your bridge length in inches divided by 8
- Motor includes holding brake

## Under-Running "SCU" Series Motorized End Truck Set

Designed for WF or I-Beam

### Model Number Chart

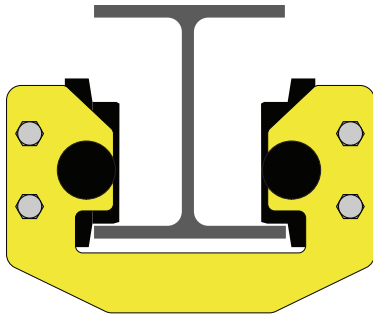
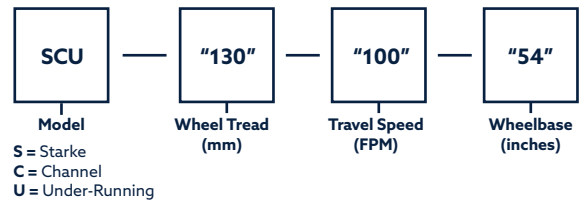

### 1/2 - 2 Ton Capacity

SKU	Cap	Speed	Wheel Tread	Wheel Base	Max Span	Voltage	HP	Amp @ 230/460 (One Motor)	Motor Rating	Bearing Life (Hrs)	MAX Wheel Loading (Pair)	Net Weight (Set)	List
SCU-110-100-42	1/2 - 2 Ton	100 FPM	4.33" (110mm)	42"	28'	230/460	0.5	3.6/1.8	H4	10,000	5,100 lbs	394 lbs	\$4,595
SCU-110-100-48	1/2 - 2 Ton	100 FPM	4.33" (110mm)	48"	32'	230/460	0.5	3.6/1.8	H4	10,000	5,100 lbs	411 lbs	\$4,637
SCU-110-100-54	1/2 - 2 Ton	100 FPM	4.33" (110mm)	54"	36'	230/460	0.5	3.6/1.8	H4	10,000	5,100 lbs	429 lbs	\$4,679
SCU-110-100-60	1/2 - 2 Ton	100 FPM	4.33" (110mm)	60"	40'	230/460	0.5	3.6/1.8	H4	10,000	5,100 lbs	446 lbs	\$4,721
SCU-110-100-66	1/2 - 2 Ton	100 FPM	4.33" (110mm)	66"	44'	230/460	0.5	3.6/1.8	H4	10,000	5,100 lbs	465 lbs	\$4,763
SCU-110-100-72	1/2 - 2 Ton	100 FPM	4.33" (110mm)	72"	48'	230/460	0.5	3.6/1.8	H4	10,000	5,100 lbs	533 lbs	\$4,805
SCU-110-100-78	1/2 - 2 Ton	100 FPM	4.33" (110mm)	78"	52'	230/460	0.5	3.6/1.8	H4	10,000	5,100 lbs	554 lbs	\$4,847

- All end truck sets ship prime painted gray
- End user to specify actual flange width of runway beam.**
- Standard size 4" – 16" flange widths. 3.25" flange widths require added package – **\$935.**
- End truck wheel base should be your bridge length in inches divided by 8.
- Motor includes holding brake.
- Tapered Wheels for S Beams Available – **Add \$400 to List Price**

# Under-Running "SCU" Series Motorized End Truck Set

## 2 - 3 Ton Capacity

SCU-130-100-48	2 - 3 Ton	100 FPM	5.12" (130mm)	48"	32'	230/460	1	5.2/2.6	H4	10,000	8,500 lbs	633 lbs	\$5,845
SCU-130-100-54	2 - 3 Ton	100 FPM	5.12" (130mm)	54"	36'	230/460	1	5.2/2.6	H4	10,000	8,500 lbs	662 lbs	\$5,885
SCU-130-100-60	2 - 3 Ton	100 FPM	5.12" (130mm)	60"	40'	230/460	1	5.2/2.6	H4	10,000	8,500 lbs	691 lbs	\$5,925
SCU-130-100-66	2 - 3 Ton	100 FPM	5.12" (130mm)	66"	44'	230/460	1	5.2/2.6	H4	10,000	8,500 lbs	720 lbs	\$5,965
SCU-130-100-72	2 - 3 Ton	100 FPM	5.12" (130mm)	72"	48'	230/460	1	5.2/2.6	H4	10,000	8,500 lbs	751 lbs	\$6,005
SCU-130-100-78	2 - 3 Ton	100 FPM	5.12" (130mm)	78"	52'	230/460	1	5.2/2.6	H4	10,000	8,500 lbs	780 lbs	\$6,045
SCU-130-100-84	2 - 3 Ton	100 FPM	5.12" (130mm)	84"	56'	230/460	1	5.2/2.6	H4	10,000	8,500 lbs	809 lbs	\$6,085

- All end truck sets ship prime painted gray
- **End user to specify actual flange width of runway beam.**
- Standard size 4" – 16" flange widths. 3.25" flange widths require added package – **\$935.**
- End truck wheel base should be your bridge length in inches divided by 8
- Motor includes holding brake
- Tapered Wheels for S Beams Available – **Add \$400 to List Price**

## 5 Ton Capacity

SCU-160-100-54	5 Ton	100 FPM	6.29" (160mm)	54"	36'	230/460	1.5	7.8/3.9	H4	10,000	15,300 lbs	990 lbs	\$7,260
SCU-160-100-60	5 Ton	100 FPM	6.29" (160mm)	60"	40'	230/460	1.5	7.8/3.9	H4	10,000	15,300 lbs	1,090 lbs	\$7,361
SCU-160-100-66	5 Ton	100 FPM	6.29" (160mm)	66"	44'	230/460	1.5	7.8/3.9	H4	10,000	15,300 lbs	1,190lbs	\$7,462
SCU-160-100-72	5 Ton	100 FPM	6.29" (160mm)	72"	48'	230/460	1.5	7.8/3.9	H4	10,000	15,300 lbs	1,290lbs	\$7,564
SCU-160-100-78	5 Ton	100 FPM	6.29" (160mm)	78"	52'	230/460	1.5	7.8/3.9	H4	10,000	15,300 lbs	1,390lbs	\$7,665
SCU-160-100-84	5 Ton	100 FPM	6.29" (160mm)	84"	56'	230/460	1.5	7.8/3.9	H4	10,000	15,300 lbs	1,490lbs	\$7,766
SCU-160-100-90	5 Ton	100 FPM	6.29" (160mm)	90"	60'	230/460	1.5	7.8/3.9	H4	10,000	15,300 lbs	1,590 lbs	\$7,867
SCU-160-100-96	5 Ton	100 FPM	6.29" (160mm)	96"	64'	230/460	1.5	7.8/3.9	H4	10,000	15,300 lbs	1,690 lbs	\$7,969

- All end truck sets ship prime painted gray
- **End user to specify actual flange width of runway beam.**
- Standard size 4" – 16" flange widths. 3.25" flange widths require added package – **\$935.**
- End truck wheel base should be your bridge length in inches divided by 8
- Motor includes holding brake
- Tapered Wheels for S Beams Available – **Add \$400 to List Price**

## Under-Running "SCU" Series Motorized End Truck Set

### 7 1/2 - 10 Ton Capacity

SCU-190-100-60	7.5 - 10 Ton	100 FPM	7.48" (190mm)	60"	40'	230/460	2	10/5	H4	10,000	25,500 lbs	1,695 lbs	\$10,147
SCU-190-100-66	7.5 - 10 Ton	100 FPM	7.48" (190mm)	66"	44'	230/460	2	10/5	H4	10,000	25,500 lbs	1,765 lbs	\$10,346
SCU-190-100-72	7.5 - 10 Ton	100 FPM	7.48" (190mm)	72"	48'	230/460	2	10/5	H4	10,000	25,500 lbs	1,835 lbs	\$10,546
SCU-190-100-78	7.5 - 10 Ton	100 FPM	7.48" (190mm)	78"	52'	230/460	2	10/5	H4	10,000	25,500 lbs	1,905 lbs	\$10,745
SCU-190-100-84	7.5 - 10 Ton	100 FPM	7.48" (190mm)	84"	56'	230/460	2	10/5	H4	10,000	25,500 lbs	1,975 lbs	\$10,945
SCU-190-100-90	7.5 - 10 Ton	100 FPM	7.48" (190mm)	90"	60'	230/460	2	10/5	H4	10,000	25,500 lbs	2,045 lbs	\$11,144
SCU-190-100-96	7.5 - 10 Ton	100 FPM	7.48" (190mm)	96"	64'	230/460	2	10/5	H4	10,000	25,500 lbs	2,115 lbs	\$11,344
SCU-190-100-102	7.5 - 10 Ton	100 FPM	7.48" (190mm)	102"	68'	230/460	2	10/5	H4	10,000	25,500 lbs	2,185 lbs	\$11,543
SCU-190-100-108	7.5 - 10 Ton	100 FPM	7.48" (190mm)	108"	72'	230/460	2	10/5	H4	10,000	25,500 lbs	2,255 lbs	\$11,743
SCU-190-100-114	7.5 - 10 Ton	100 FPM	7.48" (190mm)	114"	76'	230/460	2	10/5	H4	10,000	25,500 lbs	2,325 lbs	\$11,942
SCU-190-100-120	7.5 - 10 Ton	100 FPM	7.48" (190mm)	120"	80'	230/460	2	10/5	H4	10,000	25,500 lbs	2,395 lbs	\$12,142

- All end truck sets ship prime painted gray
- **End user to specify actual flange width of runway beam.**
- End truck wheel base should be your bridge length in inches divided by 8
- Motor includes holding brake
- Tapered Wheels for S Beams Available – **Add \$400 to List Price**



# Rubber Crane Bumpers

To be used for crane end trucks, hoist trolleys, or general industrial applications.

SKU	Size	Dimensions	List
600-50035	Small	1 1/2" Dia x 1 1/2" Length	\$14
600-50036	Medium	2 3/8" Dia x 2 3/16" Length	\$26
600-50037	Large	3 1/8" Dia x 3 1/8" Length	\$55
600-50275	Extra Large	6 5/16" Dia x 4 5/8" Length	\$90

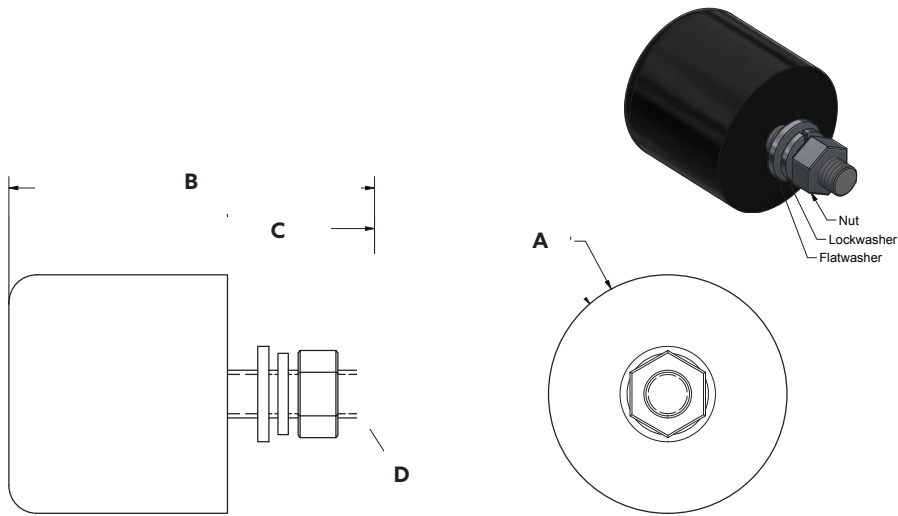

Rubber Bumper Dimensions				
	A	B	C	D
600-50035	1 1/2"	1 1/2"	1"	5/16-18 NC
600-50036	2 3/8"	2"	1 1/4"	M14 x 2.0
600-50037	3 1/8"	3 1/8"	1 1/2"	M16 x 2.0
600-50275	6 1/4"	5"	1 5/8"	M16 x 2.0

## Manual End Trucks "SBK" Under-Running Series

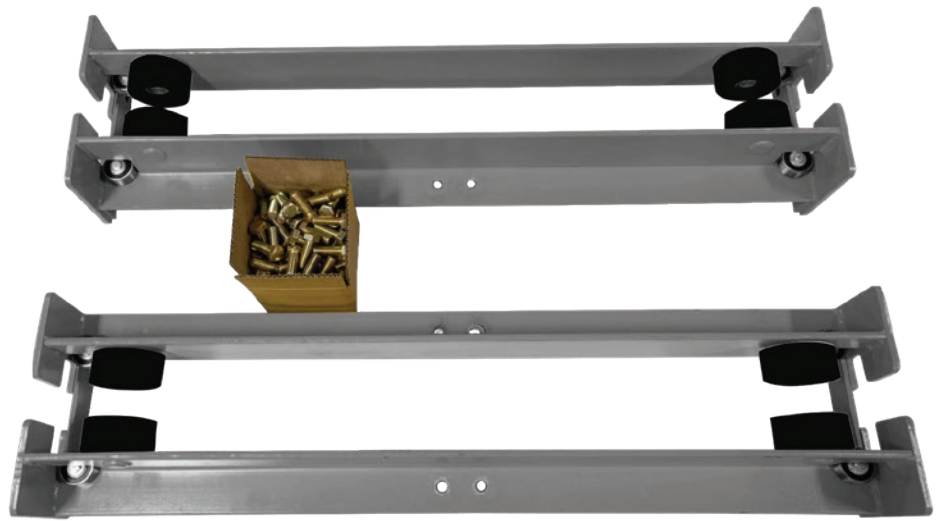
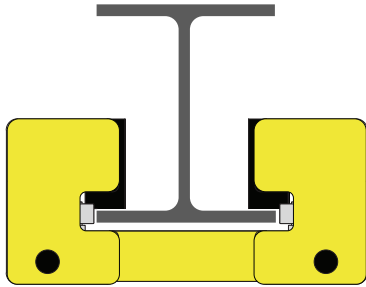

SKU	Recommended Capacity	Wheelbase	Wheel Type	Flange Width Range	MAX Wheel Loading (Pair)	Net Weight (Set)	List
SBK-1048-07	½ Ton	39.5"	4" OD ACETAL Plastic	4" - 7"	800 lbs	139 lbs	\$1,197
SBK-1048-10	½ Ton	39.5"	4" OD ACETAL Plastic	7" - 10"	800 lbs	159 lbs	\$1,257
SBK-2048-07	1 Ton	39.5"	4" OD ACETAL Plastic	4" - 7"	1,425 lbs	203 lbs	\$1,357
SBK-2048-10	1 Ton	39.5"	4" OD ACETAL Plastic	7" - 10"	1,425 lbs	223 lbs	\$1,397
SBK-4048-07	2 Ton	39.5"	4.25" OD Machined Steel	4" - 7"	2,450 lbs	243 lbs	\$1,596
SBK-4048-10	2 Ton	39.5"	4.25" OD Machined Steel	7" - 10"	2,450 lbs	263 lbs	\$1,696
SBK01ST	Upgrade Above Models to tapered wheel kit for Standard American I-Beams						\$200

- SBK01ST kit price only valid at time of end truck order
- Flange width is adjustable to any size within the flange width range.

SKU	Recommended Capacity	Wheelbase	Wheel Type	Flange Width Range	MAX Wheel Loading (Pair)	Net Weight (Set)	List
SBK-6060-07	3 Ton	50.5"	6" Machined Steel	4" - 7"	3,825 lbs	491 lbs	\$2,195
SBK-6060-10	3 Ton	50.5"	6" Machined Steel	7" - 10"	3,825 lbs	511 lbs	\$2,294

- This model is designed to run directly on Wide Flange Beam.
- Flange width is adjustable to any size within the flange width range.
- Ships prime painted gray
- Max bridge span 26'.

## "SBK" Under-Running Kits

- This page gives details of the 1 Ton (SBK-2048) manual end truck kit. For drawings of other models, contact your distributor.
- Angle bracing and beam does not ship with SBK Endtruck Kits

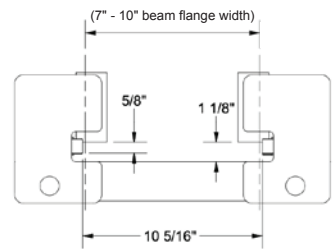
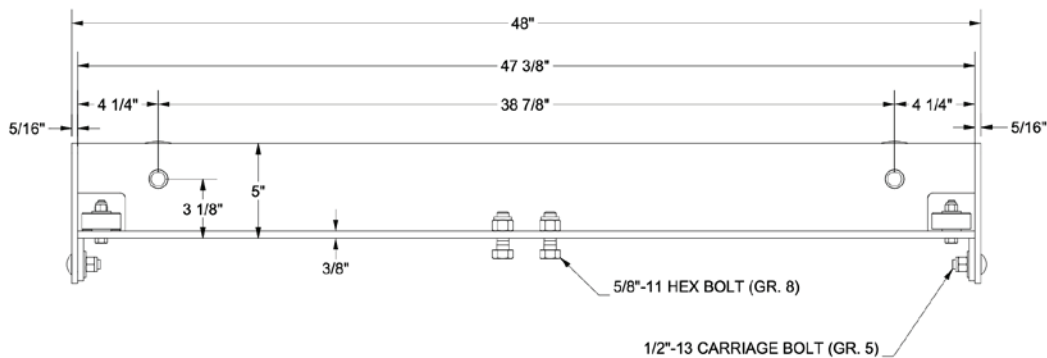
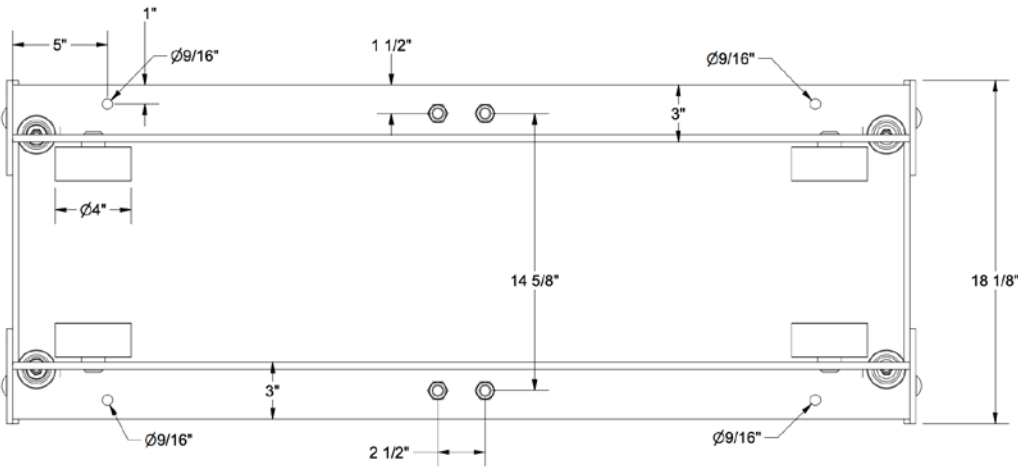

# ENCLOSED TRACK

This track is intended to sell to distributors who want to design and fabricate custom systems that are not available off the shelf from a workstation manufacturer.

## 300 Series Track

Engineered to work well as a light to medium duty option for a variety of applications from workstation cranes and jibs to fall protection.

SKU	Description	Finish	Length	Weight	List
S300-C	3" x 2.5" x 7ga (Grade #50 Steel)	Raw Unpainted	Cut to Any Custom Length	5lbs / ft	\$26/ft
S300-21	3" x 2.5" x 7ga (Grade #50 Steel)	Raw Unpainted	21' Stock	105 lbs	\$504
S300-32	3" x 2.5" x 7ga (Grade #50 Steel)	Raw Unpainted	32' Stock	160 lbs	\$736
S300-43	3" x 2.5" x 7ga (Grade #50 Steel)	Raw Unpainted	43' Stock	215 lbs	\$946
S300-53	3" x 2.5" x 7ga (Grade #50 Steel)	Raw Unpainted	53' Stock	265 lbs	\$1,113
S300-55	3" x 2.5" x 7ga (Grade #50 Steel)	Raw Unpainted	55' Stock	275 lbs	\$1,155

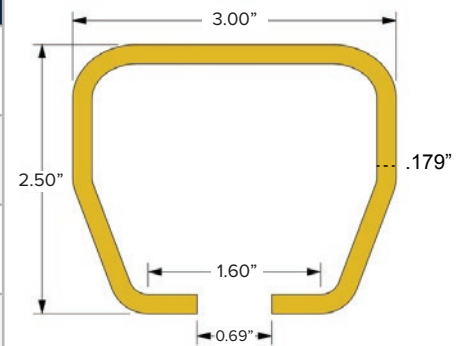

## 400 Series Track

Engineered to work well as a medium to heavy duty option for a variety of applications from workstation cranes and jibs to fall protection requiring extended spans.

SKU	Description	Finish	Length	Weight	List
S400-C	4" x 3.5" x 1/4" (Grade A36 Steel)	Raw Unpainted	Cut to Any Custom Length	9.5lbs / ft	\$41/ft
S400-37	4" x 3.5" x 1/4" (Grade A36 Steel)	Raw Unpainted	37'-8" Stock	304lbs	\$1,097

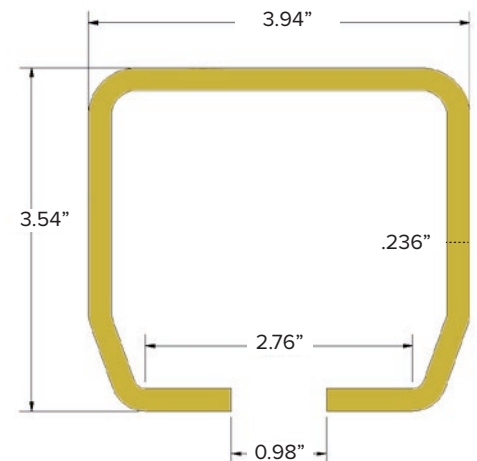

# Enclosed Track Components

SKU	Description	Track Series	Finish	Weight	List
S300-SFT	Fall Arrest Rated Trolley (420 lbs)	300	Yellow Zinc	4 lbs	\$329
S300-EMT	Hoist Trolley (Rated 1,000 lbs)	300	Yellow Zinc	3 lbs	\$297
S300-ETK	Standard Wheelbase Single End Truck (Rated 1,000 lbs)	300	Yellow Zinc	19 lbs	\$415
S300-XET	Extended Wheelbase Single End Truck (Rated 1,000 lbs)	300	Yellow Paint	57 lbs	\$689
S300-CFT	Flat Cable Festoon Trolley	300	Zinc/Plastic	0.66 lbs	\$37
S300-CET	Flat Cable Festoon End Clamp	300	Zinc/Plastic	0.85 lbs	\$17
S300-AFT	Air Hose Festoon Trolley	300	Zinc/Plastic	0.89 lbs	\$43
S300-AET	Air Hose Festoon End Clamp	300	Zinc/Plastic	0.95 lbs	\$27
S300-ESK	End Stop Kit with Rubber Bushing	300	Zinc/Rubber	0.59 lbs	\$13
S300-TSK	8" Track Splice Kit (w/set bolts)	300	Yellow Zinc	7 lbs	\$59
S400-SFT	Fall Arrest Rated Trolley (420 lbs)	400	Yellow Zinc	7 lbs	\$479
S400-EMT	Hoist Trolley (Rated 2,000 lbs)	400	Yellow Zinc	5 lbs	\$395
S400-ETK	Standard Wheelbase Single End Truck (Rated 2,000 lbs)	400	Yellow Zinc	31 lbs	\$589
S400-XET	Extended Wheelbase Single End Truck (Rated 4,000 lbs)	400	Yellow Paint	93 lbs	\$971
S400-ESK	End Stop Kit with Rubber Bushing	400	Zinc/Rubber	0.75 lbs	\$18
S400-TSK	12" Track Splice Kit (w/set bolts)	400	Yellow Zinc	11 lbs	\$79



**Fall Arrest Trolley (SFT)**



**Festoon Trolley (CFT)**



**End Truck (ETK)**



**Hoist Trolley (EMT)**



**Track Splice (TSK)**

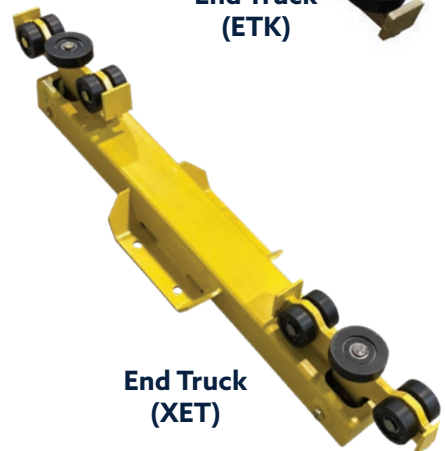

**End Truck (XET)**

# ELECTRIFICATION

## ElectroTrack

### Enclosed Conductor Bar

Complete packages below designed for straight runway and bridge systems only.

Model Number Chart

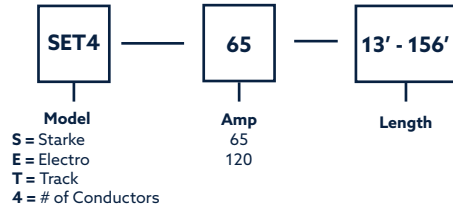

SKU	Length	Quantity/PCS	Conductor	Amp	Environment	Net Weight	List
SET4-65-26KIT	26'	2	4	65	0-155°F	26 lbs	\$688
SET4-65-39KIT	39'	3	4	65	0-155°F	37 lbs	\$908
SET4-65-52KIT	52'	4	4	65	0-155°F	47 lbs	\$1,128
SET4-65-65KIT	65'	5	4	65	0-155°F	58 lbs	\$1,348
SET4-65-78KIT	78'	6	4	65	0-155°F	69 lbs	\$1,568
SET4-65-91KIT	91'	7	4	65	0-155°F	80 lbs	\$1,788
SET4-65-104KIT	104'	8	4	65	0-155°F	94 lbs	\$2,008
SET4-65-117KIT	117'	9	4	65	0-155°F	105 lbs	\$2,228
SET4-65-130KIT	130'	10	4	65	0-155°F	116 lbs	\$2,448
SET4-65-143KIT	143'	11	4	65	0-155°F	127 lbs	\$2,668
SET4-65-156KIT	156'	12	4	65	0-155°F	138 lbs	\$2,888
SET4-120-26KIT	26'	2	4	120	0-155°F	26 lbs	\$990
SET4-120-39KIT	39'	3	4	120	0-155°F	37 lbs	\$1,265
SET4-120-52KIT	52'	4	4	120	0-155°F	47 lbs	\$1,568
SET4-120-65KIT	65'	5	4	120	0-155°F	58 lbs	\$1,870
SET4-120-78KIT	78'	6	4	120	0-155°F	69 lbs	\$2,173
SET4-120-91KIT	91'	7	4	120	0-155°F	80 lbs	\$2,475
SET4-120-104KIT	104'	8	4	120	0-155°F	94 lbs	\$2,778
SET4-120-117KIT	117'	9	4	120	0-155°F	105 lbs	\$3,080
SET4-120-130KIT	130'	10	4	120	0-155°F	116 lbs	\$3,383
SET4-120-143KIT	143'	11	4	120	0-155°F	127 lbs	\$3,685
SET4-120-156KIT	156'	12	4	120	0-155°F	138 lbs	\$3,988

- Above packages include Conductor Rail, Hangers to be supported at 79" Centers, Copper Splice Connectors, Splice Covers, (1) 40 Amp Collector with Tow Arm, End Caps, and Power End Feed.
- Installer is responsible to cut rail to exact lengths at job-site and bend/punch copper conductors at the appointed location to fit system.
- Not advised to be in direct sunlight or plastic will break down over a period of time. MFG advises heat/weather shield.

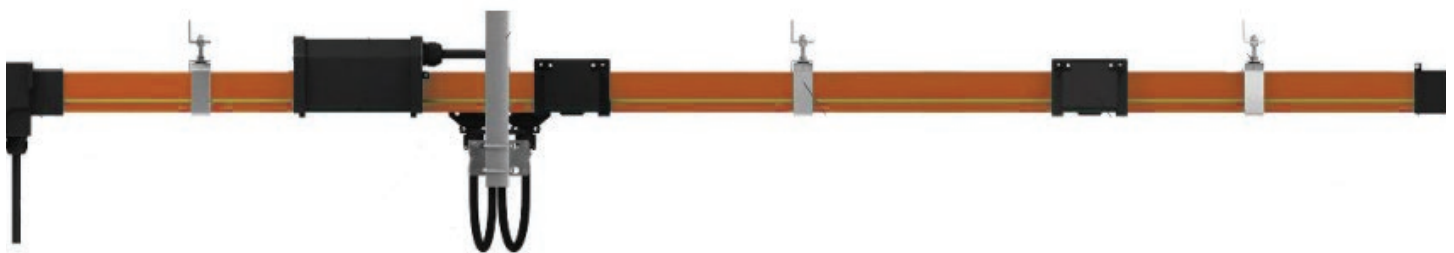

# Components Pricing

SKU	Description	Electrotrack AMP Model	Net Weight	List
SET4-65-13	13' Conductor Bar	65	13 lbs	\$255
SET4-65-13B	13' Conductor Bar 50pc Bulk	65	13 lbs	\$223/ea
SET-90072	Copper Splice Connectors	65	.03 lbs	\$4.80
SET-90085	Copper Splice Connectors 200pc Bulk	65	.03 lbs	\$4.37/ea
SET-90071	Plastic Splice Cover	65	.2 lbs	\$3.47
SET-90086	Plastic Splice Cover 50pc Bulk	65	.2 lbs	\$2.86/ea
SET-90069	Center Power Feed Kit	65	1.75 lbs	\$75
SET4-120-13	13' Conductor Bar	120	13 lbs	\$386
SET4-120-13B	13' Conductor Bar 50pc Bulk	120	650 lbs	\$337/ea
SET-90081	Copper Splice Connectors	120	.1 lbs	\$5.38
SET-90082	Copper Splice Connectors 200pc Bulk	120	20 lbs	\$4.89/ea
SET-90083	Plastic Splice Cover	120	.2 lbs	\$5.20
SET-90084	Plastic Splice Cover 50pc Bulk	120	20 lbs	\$5.02/ea
SET-90088	Center Power Feed Kit	120	1.75 lbs	\$75
SET-90075	Hanger	65/120	.1 lbs	\$5.78
SET-90087	Hanger 100 pc Bulk	65/120	10 lbs	\$4.80/ea
SET-90068	End Power Feed Kit	65/120	.6 lbs	\$26
SET-90074	End Cap	65/120	.1 lbs	\$6.35
SET-90066	40 Amp Single Collector	65/120	1.90 lbs	\$119
SET-90067	Single Tow Arm	65/120	1.03 lbs	\$25
SET-90065	Dust Seal	65/120	0.19 lbs/ ft	\$7/ft

If tandem collectors are required, figure (2) Single collectors and tow arms above

## ElectroTrack

**Enclosed Power Rail**  
 Model No: SET4-65-13  
 Lot No: 90104  
 MFG Date: 01/2020  
 Rating: 65 Amp - 4 Conductor  
 Environment: 0°F - 155°F

  
 starkeamerica.com  
MFG in China to ISO 9001 Standards



## 48 HOUR QUICK SHIP

Including Bulk Stock Listed Above.

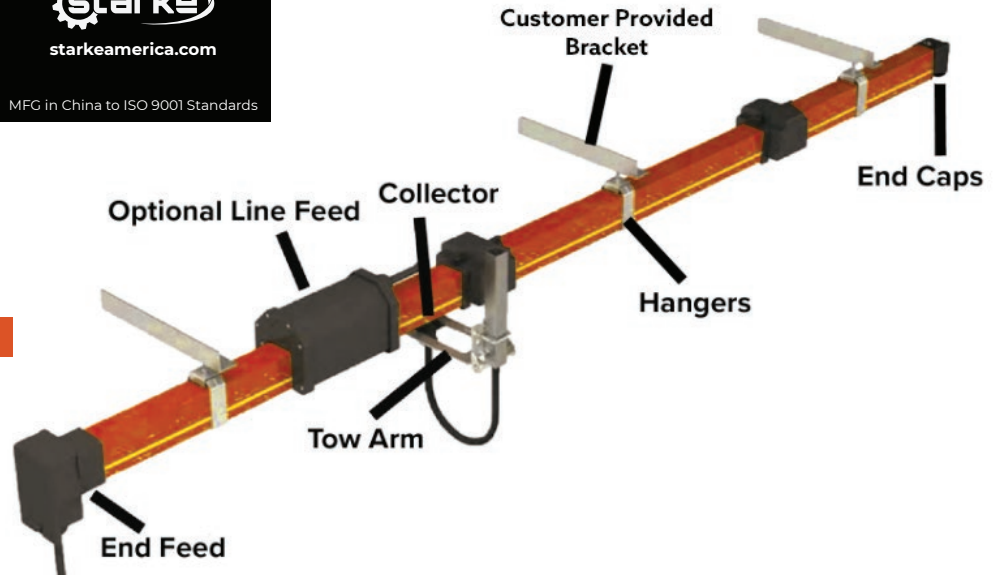

## 65 Amp (SET4-65)

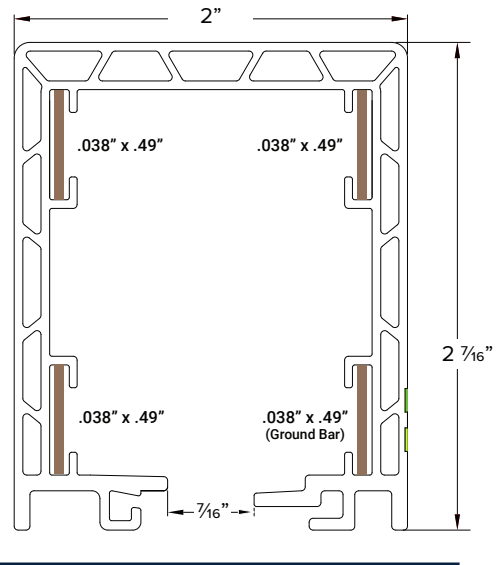

## 120 Amp (SET4-120)

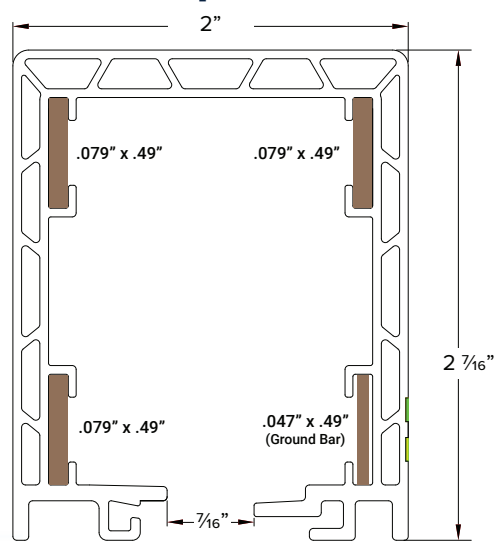

HOISTS

CRANE COMPONENTS

ELECTRIFICATION & CONTROLS

CRANE KITS

SLINGS

SAFETY

# FlexTrack

## Enclosed 65 Amp Conductor Rail

These components are not typically in stock, but are custom designed and produced for complex loop monorail systems that include horizontal turns.



Model Number Chart

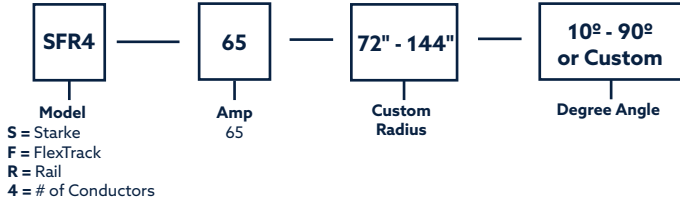

SKU	Linear Length	Custom Radius	Degree of Turn	Conductor	Amp	Environment	Net Weight	List
SFR4-65-S	13'	Straight	Straight	4	65	0-155°F	18 lbs	\$550
SFR4-65-(R)-90	13'	72"- 144"	90°	4	65	0-155°F	36 lbs	\$715
SFR4-65-(R)-45	13'	72"- 144"	45°	4	65	0-155°F	54 lbs	\$699
SFR4-65-(R)-22	13'	72"- 144"	22.5°	4	65	0-155°F	72 lbs	\$682
SFR4-65-(R)-C	13'	72"- 144"	Custom 10°-90°	4	65	0-155°F	90 lbs	\$798

- Typical lead time is 10-12 weeks after drawing approval by distributor and/or end use customer.
- All above components are 4 conductor, 65 Amps, and designed for environments between 0-155°F.
- In order to complete a 90° turn with one turn section above, we recommend the use of a 6 ft (72") radius if possible.
- Installer is responsible to cut rail to exact lengths at job-site and bend/punch copper conductors at the appointed location to fit system.
- Not advised to be in direct sunlight or plastic will break down over a period of time. MFG advises heat/weather shield.

Formula for Finding Out How Many Pieces to Order

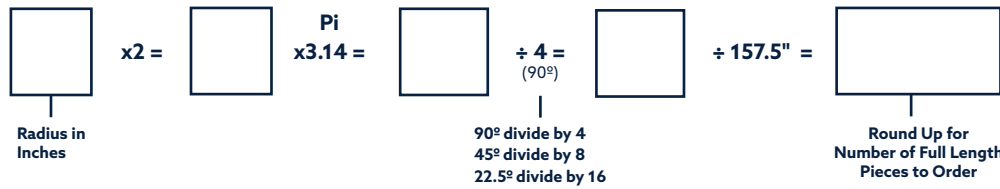

## Additional Components

SKU	Description	Net Weight	List
SFR-90071	40 Amp Single Collector for Radius	1.72 lbs	\$198
SFR-90072	Single Tow Arm	1.03 lbs	\$52
SFR-90073	End Power Feed	.55 lbs	\$99
SFR-90074	Center Power Feed	1.035 lbs	\$102
SFR-90075	Plastic Splice Cover Kit + 4 Connectors	.2 lbs	\$13
SET-90073	Hole Punch (1/4") For Power Feed	3.8 lbs	\$281

- If tandem collectors are required, simply figure (2) Single collectors and tow arms above



## 65 Amp (SFR4-65)

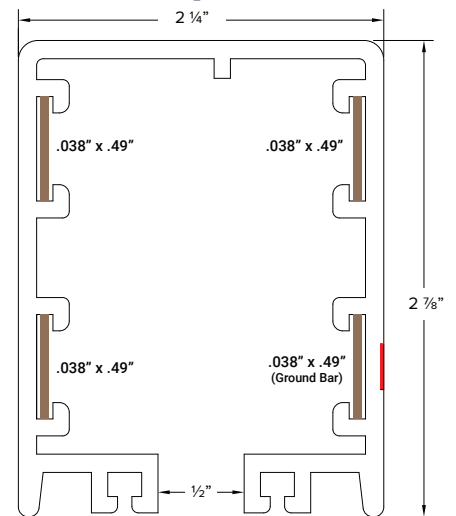

## Festoon Cable Only

SKU	# of wires	AWG	Length	Net Weight	Price per ft	List
SFC4W-14AWG	4	14	Custom per ft	.135 lbs / ft	\$2.59	Use price per ft up to 499'
SFC4W-14AWG-500	4	14	500' reel	67.5 lbs	\$2.39	\$1,195
SFC4W-14AWG-1000	4	14	1000' reel	135 lbs	\$2.23	\$2,230
SFC8W-14AWG	8	14	Custom per ft	.23 lbs / ft	\$4.47	Use price per ft up to 499'
SFC8W-14AWG-500	8	14	500' reel	115 lbs	\$4.10	\$2,050
SFC8W-14AWG-1000	8	14	1000' reel	230 lbs	\$3.83	\$3,830
SFC12W-14AWG	12	14	Custom per ft	.36 lbs / ft	\$5.92	Use price per ft up to 499'
SFC12W-14AWG-500	12	14	500' reel	180 lbs	\$5.40	\$2,700
SFC12W-14AWG-1000	12	14	1000' reel	360 lbs	\$5.04	\$5,040
SFC4W-10AWG	4	10	Custom per ft	.22 lbs / ft	\$4.79	Use price per ft up to 499'
SFC4W-10AWG-500	4	10	500' reel	110 lbs	\$4.49	\$2,245
SFC4W-10AWG-1000	4	10	1000' reel	220 lbs	\$4.26	\$4,260



## Festoon System Components

SKU	Description	Specs	Weight	List
S100-13	C-Track 13.12' Length (4m)	Zinc	9.9 lbs	\$35
S100-SH	Single Bolt Standard Hanger	Zinc	0.4 lbs	\$5.68
S100-AH	Single Bolt Anchor Hanger	Zinc	0.42 lbs	\$9.98
S100-TC	Track Coupler Assembly	Zinc	0.9 lbs	\$10.26
S100-EC	Track End Cap	Rubber	0.02 lbs	\$1.37
S100-CFT	Flat Cable Festoon Trolley	Zinc/Plastic	0.6 lbs	\$16.86
S100-CET	Flat Cable Festoon End Clamp	Zinc/Plastic	0.61 lbs	\$13.28
S100-AFT	Air Hose Festoon Trolley	Zinc/Plastic Max Hose: 1" OD	0.78 lbs	\$24.04
S100-AET	Air Hose Festoon End Clamp	Zinc/Plastic	0.68 lbs	\$14.57

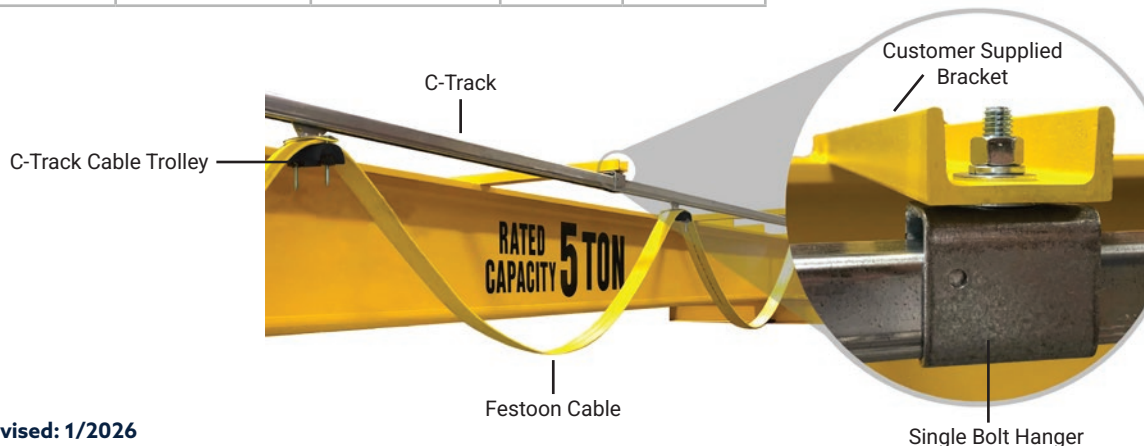
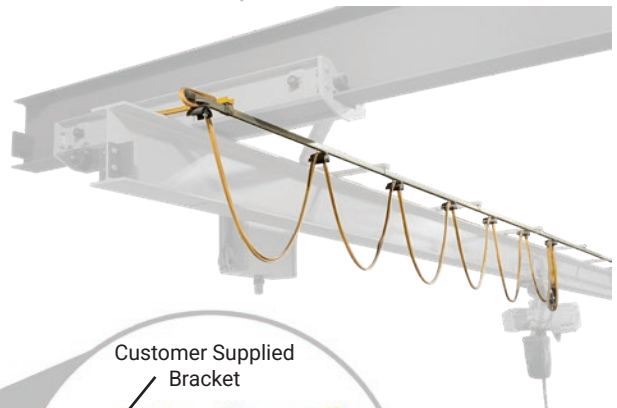
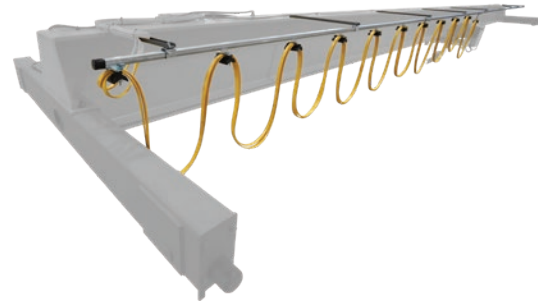

## Power & Control Cable

SKU	Length	# of wires	Gauge	Volt	Max Amps	Net Weight	Price per ft	List
SPC-614-1	Per foot	6	14	600V	15	0.14 lbs	\$3.98	\$3.98
SPC-614-25	25' reel	6	14	600V	15	3.5 lbs	\$3.98	\$99.50
SPC-614-50	50' reel	6	14	600V	15	7 lbs	\$3.98	\$199
SPC-614-100	100' reel	6	14	600V	15	14 lbs	\$3.98	\$398
SPC-614-250	250' reel	6	14	600V	15	35 lbs	\$3.98	\$995
SPC-614-500	500' reel	6	14	600V	15	70 lbs	\$3.43	\$1,714
SPC-614-1000	1000' reel	6	14	600V	15	140 lbs	\$2.99	\$2,990
SPC-410-1	per foot	4	10	600V	30	0.26 lbs	\$8.80	\$8.80
SPC-410-25	25' reel	4	10	600V	30	6.5 lbs	\$8.80	\$220
SPC-410-50	50' reel	4	10	600V	30	13 lbs	\$8.80	\$440
SPC-410-100	100' reel	4	10	600V	30	26 lbs	\$8.80	\$880
SPC-410-250	250' reel	4	10	600V	30	65 lbs	\$8.80	\$2,200
SPC-410-500	500' reel	4	10	600V	30	130 lbs	\$7.67	\$3,836
SPC-410-1000	1000' reel	4	10	600V	30	260 lbs	\$6.78	\$6,776

- Gauges shown above are nominal sizes. Actual metric sizes are: 14 gauge = 2mm<sup>2</sup> / 10 gauge = 5.5mm<sup>2</sup>
- 10 gauge wire is conveniently colored Red, Black, White & Green (ground)
- 14 gauge wires are all white in color and labeled #1 - #6



## Internal Strain Relief Pendant Cable

SKU	Length	# of wires	Gauge	Net Weight	Price per ft	List
SPCI0316-1	1'	3	16	0.125 lbs	\$5.17	\$5.17
SPCI0316-25	25'	3	16	3.125 lbs	\$4.64	\$116
SPCI0316-50	50'	3	16	6.25 lbs	\$4.68	\$234
SPCI0316-100	100'	3	16	12.5 lbs	\$4.56	\$456
SPCI0316-250	250'	3	16	31.25 lbs	\$4.42	\$1,104
SPCI0316-500	500'	3	16	62.5 lbs	\$4.23	\$2,117
SPCI0316-1000	1000'	3	16	125 lbs	\$3.97	\$3,965

SPCI Cable works well as a replacement for most chain hoist models utilizing .50" OD internal strain relief pendant cable.



# Twist Lock Plugs

SKU	Type	NEMA	Voltage	Amp	# of Wires	Net Weight	List
STL515F	Female	L5-15C	125	15	3	.335 lbs	\$17.36
STL515M	Male	L5-15P	125	15	3	.335 lbs	\$15.59
STL520F	Female	L5-20C	125	20	3	.335 lbs	\$19.41
STL520M	Male	L5-20P	125	20	3	.335 lbs	\$19.41
STL530F	Female	L5-30C	125	30	3	.335 lbs	\$23.22
STL530M	Male	L5-30P	125	30	3	.335 lbs	\$21.35
STL620F	Female	L6-20C	250	20	3	.335 lbs	\$23.22
STL620M	Male	L6-20P	250	20	3	.335 lbs	\$21.35
STL630F	Female	L6-30C	250	30	3	.335 lbs	\$23.22
STL630M	Male	L6-30P	250	30	3	.335 lbs	\$21.35
STL1620F	Female	L16-20C	480	20	4	.335 lbs	\$27.45
STL1620M	Male	L16-20P	480	20	4	.335 lbs	\$26.35
STL1630F	Female	L16-30C	480	30	4	.335 lbs	\$32.21
STL1630M	Male	L16-30P	480	30	4	.335 lbs	\$29.92
STL1520F	Female	L15-20C	250	20	4	.335 lbs	\$25.26
STL1520M	Male	L15-20P	250	20	4	.335 lbs	\$24.88



**3-Wire**



**4-Wire**

# CONTROLS

## VFD Bridge Control Panels

SKU	Line Voltage	Combined Max Drive HP	Max Total Bridge HP	Max Total Amps	Panel Size (W) x (H) x (D)	Net Weight	List
SCP-0246	460/3	2	24	31	22" X 18" X 10"	57 lbs	\$2,992
SCP-0346	460/3	3	28	36	22" X 18" X 10"	59 lbs	\$3,189
SCP-0446	460/3	4	28	36	22" X 18" X 10"	61 lbs	\$3,523
SCP-0546	460/3	5	38	49	22" X 18" X 10"	63 lbs	\$4,583
SCP-0746	460/3	7.5	38	49	22" X 18" X 10"	63 lbs	\$4,911
SCP-1046	460/3	10	50	63	22" X 18" X 10"	82 lbs	\$5,991
SCP-0323	208/230/3	3	22/25	63	22" X 18" X 10"	59 lbs	\$3,529
SCP-0523	208/230/3	5	22/25	63	22" X 18" X 10"	61 lbs	\$4,583
SCP-323S	230 Single Phase	3	14	63	22" X 18" X 10"	59 lbs	\$4,747

\*Features Inverter/VFD to convert single phase incoming line voltage to 3-phase, powering end trucks only. Hoist and trolley require single phase.

### General Panel Specifications

- Includes Main Line Contactors
- Through-the-Door Mainline Disconnect Plus Over-Current Circuit Protection
- Amber Strobe Warning Light pre-wired to indicate bridge is in motion
- Wiring & Components neatly installed and labeled allowing easy trouble-shooting & traceability
- All panels feature NEMA 3 Rating



**48 Hour Quick Ship | Models Listed Above.** All other models have a 2-3 week lead time from factory.



## VFD TECHNOLOGY

FEATURING

## DANFOSS DRIVES



### VLT Micro Drive



- Infinite Speed Adjustment
- Improves Load Control
- Soft Start & Stop
- Adjustable Ramp Up & Down
- Adjustable High & Low Speeds



Emergency Stop

LED Indicator Lights



Ergonomic Comfort



Impact Resistant Shell

Variable Voltage Receiver



Receiving Status Indication

## Technical Data

Transmitter		Receiver	
Frequency Range	255 Channel Options 425MHz ~ 474MHz	Frequency Range	255 Channel Options a425MHz ~ 474MHz
Typical Operating Range	328 ft	Sensitivity	-112dBm@baud1.2k bps
Typical Response Time	50mS ~ 100mS	Typical Response Time	50 mS ~ 100 mS
Average Power Consumption	16mA@DC3V (default setting)	Standby Power	16mA@AC220V
Radio – Frequency Power	<10dBm (default setting)	Operating Temperature	-31 F - 176 F
Operating Temperature	-31 F - 176 F	Enclosure Rating	Nema 4 / IP65
Enclosure Rating	Nema 4 / IP65	Housing Material	PA6 (30% GF)
Housing Material	PA6 (30% GF)	Certifications	FCC & CE Compliant
Certifications	FCC & CE Compliant		



# RADIO CONTROL KITS



A radio control kit that comes with the following components:

- (2) Transmitters
- Receiver
- Batteries
- (1) Lanyard
- (1) Button Cover
- Mounting Hardware



## S601 Series

### SINGLE SPEED

SKU	Control Type	Motions	Speeds	Receiver Quantity	Receiver Power Supply	Transmitter Power Supply	Freq	Net Weight	List
S601-1R-1M-SD	Standard	1	1	1	24V-264V AC/DC	(2) AA Batteries	433 MHz	6.1 lb	\$564
S601-1R-2M-SD	Standard	2	1	1	24V-264V AC/DC	(2) AA Batteries	433 MHz	6.1 lb	\$608
S601-1R-3M-SD	Standard	3	1	1	24V-264V AC/DC	(2) AA Batteries	433 MHz	6.1 lb	\$651
S601-1R-1M-AB	A/B/Both Capable	1	1	1	24V-264V AC/DC	(2) AA Batteries	433 MHz	6.1 lb	\$694
S601-1R-2M-AB	A/B/Both Capable	2	1	1	24V-264V AC/DC	(2) AA Batteries	433 MHz	6.1 lb	\$738
S601-2R-1M-SD	Standard	1	1	2	24V-264V AC/DC	(2) AA Batteries	433 MHz	6.1 lb	\$911
S601-2R-2M-SD	Standard	2	1	2	24V-264V AC/DC	(2) AA Batteries	433 MHz	6.1 lb	\$955
S601-2R-3M-SD	Standard	3	1	2	24V-264V AC/DC	(2) AA Batteries	433 MHz	6.1 lb	\$998
S601-2R-1M-AB	A/B/Both Capable	1	1	2	24V-264V AC/DC	(2) AA Batteries	433 MHz	6.1 lb	\$955
S601-2R-2M-AB	A/B/Both Capable	2	1	2	24V-264V AC/DC	(2) AA Batteries	433 MHz	6.1 lb	\$998

# RADIO CONTROL KITS



A radio control kit that comes with the following components:

- (2) Transmitters
- Receiver
- Batteries
- (1) Lanyard
- (1) Button Cover
- Mounting Hardware



## S802 Series

### 2-SPEED

SKU	Control Type	Motions	Speeds	Receiver Quantity	Receiver Power Supply	Transmitter Power Supply	Freq	Net Weight	List
S802-1R-1M-SD	Standard	1	2	1	24V-264V AC/DC	(2) AA Batteries	433 MHz	6.6 lb	\$1,042
S802-1R-2M-SD	Standard	2	2	1	24V-264V AC/DC	(2) AA Batteries	433 MHz	6.6 lb	\$1,085
S802-1R-3M-SD	Standard	3	2	1	24V-264V AC/DC	(2) AA Batteries	433 MHz	6.6 lb	\$1,128
S802-1R-4M-SD	Standard	4	2	1	24V-264V AC/DC	(2) AA Batteries	433 MHz	6.6 lb	\$1,172
S802-1R-1M-AB	A/B/Both Capable	1	2	1	24V-264V AC/DC	(2) AA Batteries	433 MHz	6.6 lb	\$1,085
S802-1R-2M-AB	A/B/Both Capable	2	2	1	24V-264V AC/DC	(2) AA Batteries	433 MHz	6.6 lb	\$1,172
S802-1R-3M-AB	A/B/Both Capable	3	2	1	24V-264V AC/DC	(2) AA Batteries	433 MHz	6.6 lb	\$1,215
S802-2R-1M-SD	Standard	1	2	2	24V-264V AC/DC	(2) AA Batteries	433 MHz	6.6 lb	\$1,432
S802-2R-2M-SD	Standard	2	2	2	24V-264V AC/DC	(2) AA Batteries	433 MHz	6.6 lb	\$1,476
S802-2R-3M-SD	Standard	3	2	2	24V-264V AC/DC	(2) AA Batteries	433 MHz	6.6 lb	\$1,519
S802-2R-4M-SD	Standard	4	2	2	24V-264V AC/DC	(2) AA Batteries	433 MHz	6.6 lb	\$1,562
S802-2R-1M-AB	A/B/Both Capable	1	2	2	24V-264V AC/DC	(2) AA Batteries	433 MHz	6.6 lb	\$1,476
S802-2R-2M-AB	A/B/Both Capable	2	2	2	24V-264V AC/DC	(2) AA Batteries	433 MHz	6.6 lb	\$1,519
S802-2R-3M-AB	A/B/Both Capable	3	2	2	24V-264V AC/DC	(2) AA Batteries	433 MHz	6.6 lb	\$1,562
S802-3R-1M-SD	Standard	1	2	3	24V-264V AC/DC	(2) AA Batteries	433 MHz	6.6 lb	\$1,779
S802-3R-2M-SD	Standard	2	2	3	24V-264V AC/DC	(2) AA Batteries	433 MHz	6.6 lb	\$1,823
S802-3R-3M-SD	Standard	3	2	3	24V-264V AC/DC	(2) AA Batteries	433 MHz	6.6 lb	\$1,866
S802-3R-4M-SD	Standard	4	2	3	24V-264V AC/DC	(2) AA Batteries	433 MHz	6.6 lb	\$1,886
S802-3R-1M-AB	A/B/Both Capable	1	2	3	24V-264V AC/DC	(2) AA Batteries	433 MHz	6.6 lb	\$1,823
S802-3R-2M-AB	A/B/Both Capable	2	2	3	24V-264V AC/DC	(2) AA Batteries	433 MHz	6.6 lb	\$1,866
S802-3R-3M-AB	A/B/Both Capable	3	2	3	24V-264V AC/DC	(2) AA Batteries	433 MHz	6.6 lb	\$1,910

## Collision Avoidance Kits

SKU	Description	Application	Net Weight	List
SCA-LE-50S	Single Event LED	Simple uni-directional bridge collision avoidance with (1) adjustable event (0-50 ft)	3 lbs	\$420
SCA-LE-50T	Single Event Twin LED	Simple bi-directional bridge collision avoidance with (1) adjustable event (0-50 ft)	5 lbs	\$820
SCA-LZ-200S	Dual Event Single LASER	Precision uni-directional bridge collision avoidance with (2) programmable events (0-200ft)	5 lbs	\$1,216
SCA-LZ-200T	Dual Event Twin LASER	Precision bi-directional bridge collision avoidance with (2) programmable events (0-200ft)	8 lbs	\$2,279

- All kits include LED or LASER device(s), mounting brackets, reflector(s) on mounting bracket, control cable(s), and any required relay controls.
- An “Event” is simply a measurable action that can dictate the speed or the stopping of the moving crane. A single laser may have dual events, but can still only point in one direction, which may require a “Twin” system if there are functions to be controlled in both directions



Single Event LED



Single Event Twin LED



Dual Event Single LASER



Dual Event Twin LASER

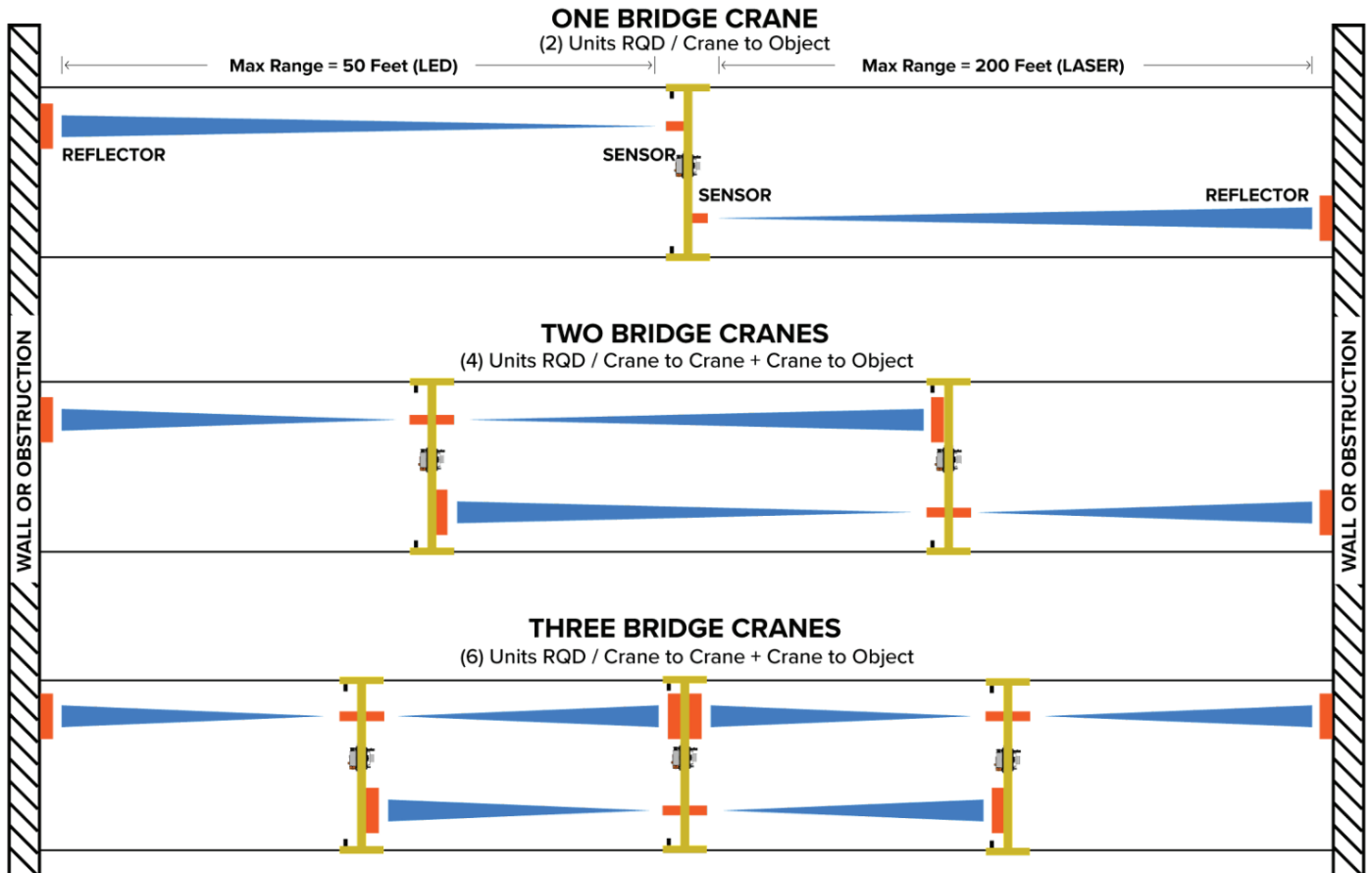
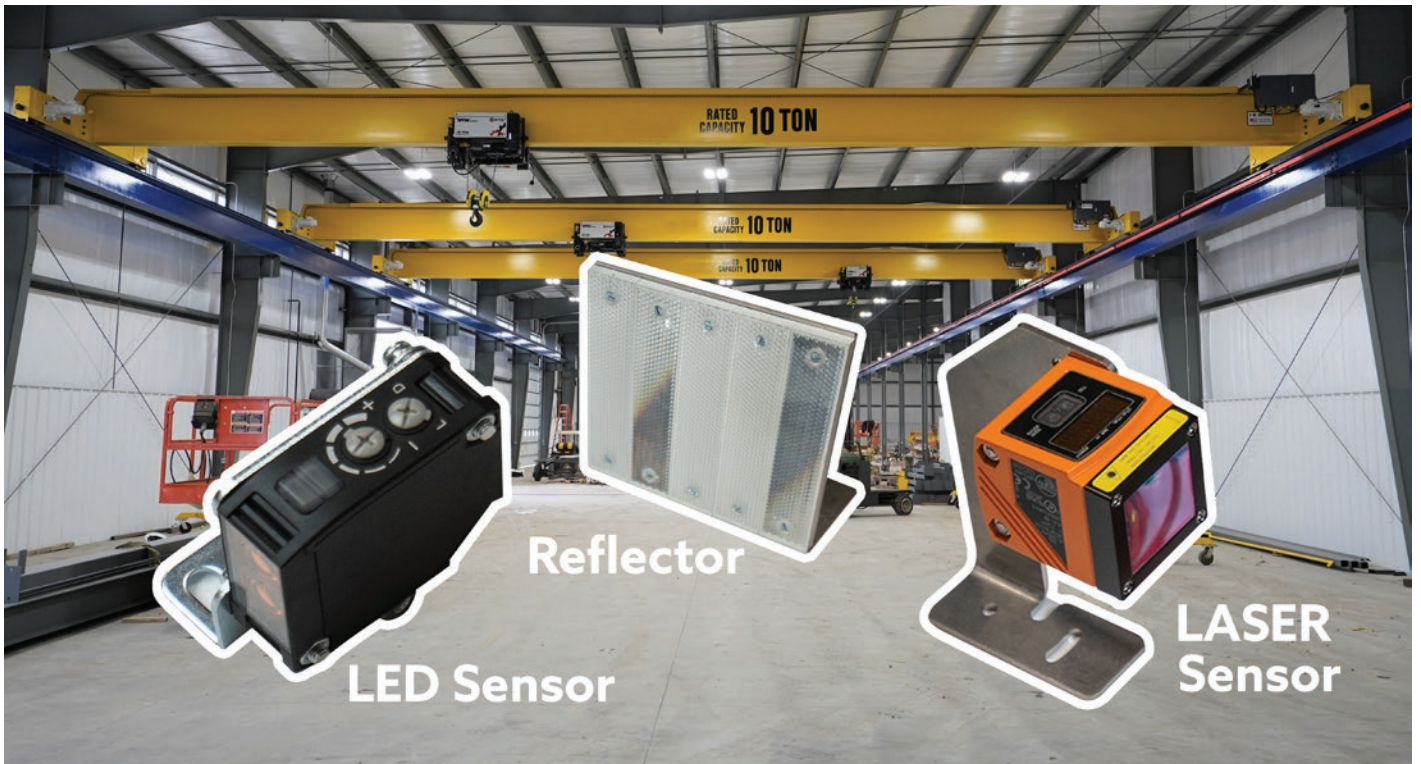

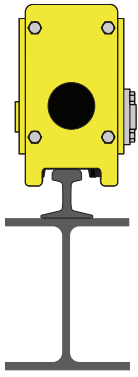

# TOP-RUNNING CRANE KITS

A complete crane kit that comes with the following components:

- (2) End Trucks with Girder Plates (prime-painted gray)
- (2) Gearmotors with quick-plug adaptors
- (4) Rubber Bumpers for end trucks
- (1) VFD Bridge Control Panel with Mounting Bracket
- (1) Bridge Crane Power Feed & Endtruck Cable Kit with Quick Plug to Panel
- (2) Adjustable Bridge End Stop Kits for Hoist Travel
- (1) Short Motor Power & Control Cable
- (1) Long Motor Power & Control Cable
- (1) Runway Electrification Mount with 10' Panel Power Supply
- Zip Tie & Clamp Kit for Cable Management
- Capacity Decal Kit
- Power & Control Package Options A, B, or C



Optional Stationary Emergency Pendant Control with 17' Drop Cord & Quick-Plug to Control Panel (\$435 Add-On)

## KITS INCLUDE:

### Hoist Options



#### Electric Chain Hoists with Trolley

Standard 20' Lift. Other lift options are available.

OR



#### Wire Rope Hoists

Standard 20' Lift. Other lift options are available.

### End Trucks



### Gear Motors



# Included in Crane Kits

HOISTS

CRANE COMPONENTS

ELECTRIFICATION & CONTROLS

CRANE KITS

SLINGS

SAFETY

## VFD Control Panel with Amber Strobe Light



## Power Feed Cable



Control Panel Mounting Bracket



Quick Plug Connectors for All Cable Connections

## Motor Feed Cables



Cable Management Kit



Adjustable Bridge Crane End Stops



End Truck Bumpers

# Crane Package "A" Controls

Power & Controls Festoon Package  
(No Pendant or Radio Included)

## Festoon Package



## Power & Control Cables



## Crane Package "B" Controls

Power & Controls Festoon Package including Independent Traveling Pendant Station



HOISTS

CRANE COMPONENTS

ELECTRIFICATION &amp; CONTROLS

## Crane Package "C" Controls

Festoonless ElectroTrack Package + Starke Echo Series S802 Radio Control for Wireless Communication to Hoist, Trolley, and End Trucks (Includes 2 Transmitters)



CRANE KITS

SLINGS

SAFETY

## 2 Ton Crane Kits

STK Electric Chain Hoist + SMT Motorized Trolley  
20' Lift, Single Speed Lift 26 FPM & 2 Speed Trolley



### How to Order

Please designate letter for electrification options at the end of the SKU.

#### Examples:

SCK-02-EC-TB20-**A** (Festoon Only)

SCK-02-EC-TB36-**B** (Traveling Pendant)

SCK-02-EC-TB60-**C** (Radio Kit)

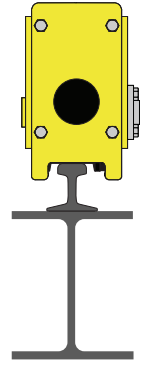

SKU	Cap	Max Bridge Span (ft)	Sugg. Bridge Beam	Endtruck Model	Endtruck Wheel Tread	Hoist + Trolley Model	System Voltage	Net Weight (lbs)	List Price Options		
									A	B	C
									Festoon Only	Traveling Pendant	Radio Kit
SCK-02-EC-TB20	2 Ton	20	W 12x26	STT-130-100-42	5.12" (130mm)	STK2026-20 + SMT20VSL	230 or 460 3 PH	1,179	\$17,112	\$18,148	\$19,050
SCK-02-EC-TB24	2 Ton	24	W 14x30	STT-130-100-42	5.12" (130mm)	STK2026-20 + SMT20VSL	230 or 460 3 PH	1,183	\$17,188	\$18,323	\$19,134
SCK-02-EC-TB28	2 Ton	28	W 14x34	STT-130-100-42	5.12" (130mm)	STK2026-20 + SMT20VSL	230 or 460 3 PH	1,187	\$17,264	\$18,497	\$19,218
SCK-02-EC-TB32	2 Ton	32	W 14x43	STT-130-100-48	5.12" (130mm)	STK2026-20 + SMT20VSL	230 or 460 3 PH	1,213	\$17,550	\$18,882	\$19,511
SCK-02-EC-TB36	2 Ton	36	W 14x53	STT-130-100-54	5.12" (130mm)	STK2026-20 + SMT20VSL	230 or 460 3 PH	1,240	\$17,836	\$19,267	\$19,805
SCK-02-EC-TB40	2 Ton	40	W 16x67	STT-130-100-60	5.12" (130mm)	STK2026-20 + SMT20VSL	230 or 460 3 PH	1,266	\$18,367	\$19,897	\$20,343
SCK-02-EC-TB44	2 Ton	44	W 16x67	STT-130-100-66	5.12" (130mm)	STK2026-20 + SMT20VSL	230 or 460 3 PH	1,293	\$18,653	\$20,282	\$20,637
SCK-02-EC-TB48	2 Ton	48	W 18x76	STT-130-100-72	5.12" (130mm)	STK2026-20 + SMT20VSL	230 or 460 3 PH	1,319	\$18,938	\$20,665	\$20,929
SCK-02-EC-TB52	2 Ton	52	W 18x76	STT-130-100-78	5.12" (130mm)	STK2026-20 + SMT20VSL	230 or 460 3 PH	1,345	\$19,224	\$21,050	\$21,223
SCK-02-EC-TB56	2 Ton	56	W 21x101	STT-130-100-84	5.12" (130mm)	STK2026-20 + SMT20VSL	230 or 460 3 PH	1,372	\$19,568	\$21,493	\$21,575
SCK-02-EC-TB60	2 Ton	60	W 21x101	STT-130-100-90	5.12" (130mm)	STK2026-20 + SMT20VSL	230 or 460 3 PH	1,398	\$19,854	\$21,878	\$21,868
SCK-02-EC-TB64	2 Ton	64	W 21x111	STT-130-100-96	5.12" (130mm)	STK2026-20 + SMT20VSL	230 or 460 3 PH	1,425	\$20,139	\$22,262	\$22,161

## 3 Ton Crane Kits

STK Electric Chain Hoist + SMT Motorized Trolley  
20' Lift, Single Speed Lift 21 FPM & 2 Speed Trolley



### How to Order

Please designate letter for electrification options at the end of the SKU.

#### Examples:

SCK-03-EC-TB20-**A** (Festoon Only)

SCK-03-EC-TB36-**B** (Traveling Pendant)

SCK-03-EC-TB60-**C** (Radio Kit)

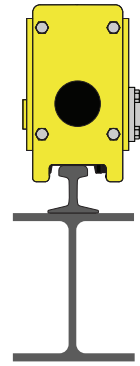

HOISTS

CRANE COMPONENTS

ELECTRIFICATION &amp; CONTROLS

CRANE KITS

SLINGS

SAFETY

SKU	Cap	Max Bridge Span (ft)	Sugg. Bridge Beam	Endtruck Model	Endtruck Wheel Tread	Hoist + Trolley Model	System Voltage	Net Weight (lbs)	List Price Options		
									A	B	C
									Festoon Only	Traveling Pendant	Radio Kit
SCK-03-EC-TB20	3 Ton	20	W 12x40	STT-130-100-42	5.12" (130mm)	STK3021-20 + SMT30VSL	230 or 460 3 PH	1,158	\$18,954	\$19,990	\$20,892
SCK-03-EC-TB24	3 Ton	24	W 12x40	STT-130-100-42	5.12" (130mm)	STK3021-20 + SMT30VSL	230 or 460 3 PH	1,162	\$19,030	\$20,165	\$20,976
SCK-03-EC-TB28	3 Ton	28	W 14x43	STT-130-100-42	5.12" (130mm)	STK3021-20 + SMT30VSL	230 or 460 3 PH	1,166	\$19,106	\$20,340	\$21,060
SCK-03-EC-TB32	3 Ton	32	W 14x61	STT-130-100-48	5.12" (130mm)	STK3021-20 + SMT30VSL	230 or 460 3 PH	1,192	\$19,672	\$21,004	\$21,632
SCK-03-EC-TB36	3 Ton	36	W 16x67	STT-130-100-54	5.12" (130mm)	STK3021-20 + SMT30VSL	230 or 460 3 PH	1,219	\$19,958	\$21,388	\$21,926
SCK-03-EC-TB40	3 Ton	40	W 16x67	STT-130-100-60	5.12" (130mm)	STK3021-20 + SMT30VSL	230 or 460 3 PH	1,245	\$20,244	\$21,773	\$22,220
SCK-03-EC-TB44	3 Ton	44	W 18x76	STT-130-100-66	5.12" (130mm)	STK3021-20 + SMT30VSL	230 or 460 3 PH	1,272	\$20,530	\$22,158	\$22,513
SCK-03-EC-TB48	3 Ton	48	W 18x86	STT-130-100-72	5.12" (130mm)	STK3021-20 + SMT30VSL	230 or 460 3 PH	1,298	\$20,815	\$22,542	\$22,806
SCK-03-EC-TB52	3 Ton	52	W 21x101	STT-130-100-78	5.12" (130mm)	STK3021-20 + SMT30VSL	230 or 460 3 PH	1,324	\$21,169	\$22,995	\$23,168
SCK-03-EC-TB56	3 Ton	56	W 21x101	STT-130-100-84	5.12" (130mm)	STK3021-20 + SMT30VSL	230 or 460 3 PH	1,351	\$21,455	\$23,380	\$23,461
SCK-03-EC-TB60	3 Ton	60	W 21x111	STT-130-100-90	5.12" (130mm)	STK3021-20 + SMT30VSL	230 or 460 3 PH	1,377	\$21,741	\$23,764	\$23,755
SCK-03-EC-TB64	3 Ton	64	W 24x131	STT-130-100-96	5.12" (130mm)	STK3021-20 + SMT30VSL	230 or 460 3 PH	1,404	\$22,026	\$24,148	\$24,047

### 3 Ton Crane Kits

STK VS Electric Chain Hoist + SMT Motorized Trolley  
20' Lift, 2 Speed Lift 21/6 FPM & 2 Speed Trolley



#### How to Order

Please designate letter for electrification options at the end of the SKU.

#### Examples:

SCK-03-VS-TB20-**A** (Festoon Only)

SCK-03-VS-TB36-**B** (Traveling Pendant)

SCK-03-VS-TB60-**C** (Radio Kit)

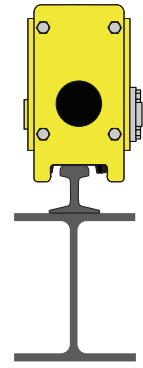

SKU	Cap	Max Bridge Span (ft)	Sugg. Bridge Beam	Endtruck Model	Endtruck Wheel Tread	Hoist + Trolley Model	System Voltage	Net Weight (lbs)	List Price Options		
									A	B	C
									Festoon Only	Traveling Pendant	Radio Kit
SCK-03-VS-TB20	3 Ton	20	W 12x40	STT-130-100-42	5.12" (130mm)	STK30VS-20 + SMT30VSL	230 or 460 3 PH	1,172	\$19,570	\$20,606	\$21,508
SCK-03-VS-TB24	3 Ton	24	W 12x40	STT-130-100-42	5.12" (130mm)	STK30VS-20 + SMT30VSL	230 or 460 3 PH	1,176	\$19,646	\$20,780	\$21,592
SCK-03-VS-TB28	3 Ton	28	W 14x43	STT-130-100-42	5.12" (130mm)	STK30VS-20 + SMT30VSL	230 or 460 3 PH	1,180	\$19,722	\$20,955	\$21,675
SCK-03-VS-TB32	3 Ton	32	W 14x61	STT-130-100-48	5.12" (130mm)	STK30VS-20 + SMT30VSL	230 or 460 3 PH	1,206	\$20,287	\$21,619	\$22,248
SCK-03-VS-TB36	3 Ton	36	W 16x67	STT-130-100-54	5.12" (130mm)	STK30VS-20 + SMT30VSL	230 or 460 3 PH	1,233	\$20,573	\$22,004	\$22,542
SCK-03-VS-TB40	3 Ton	40	W 16x67	STT-130-100-60	5.12" (130mm)	STK30VS-20 + SMT30VSL	230 or 460 3 PH	1,259	\$20,859	\$22,389	\$22,835
SCK-03-VS-TB44	3 Ton	44	W 18x76	STT-130-100-66	5.12" (130mm)	STK30VS-20 + SMT30VSL	230 or 460 3 PH	1,286	\$21,145	\$22,773	\$23,129
SCK-03-VS-TB48	3 Ton	48	W 18x86	STT-130-100-72	5.12" (130mm)	STK30VS-20 + SMT30VSL	230 or 460 3 PH	1,312	\$21,430	\$23,157	\$23,421
SCK-03-VS-TB52	3 Ton	52	W 21x101	STT-130-100-78	5.12" (130mm)	STK30VS-20 + SMT30VSL	230 or 460 3 PH	1,338	\$21,784	\$23,610	\$23,783
SCK-03-VS-TB56	3 Ton	56	W 21x101	STT-130-100-84	5.12" (130mm)	STK30VS-20 + SMT30VSL	230 or 460 3 PH	1,365	\$22,070	\$23,995	\$24,077
SCK-03-VS-TB60	3 Ton	60	W 21x111	STT-130-100-90	5.12" (130mm)	STK30VS-20 + SMT30VSL	230 or 460 3 PH	1,391	\$22,356	\$24,380	\$24,370
SCK-03-VS-TB64	3 Ton	64	W 24x131	STT-130-100-96	5.12" (130mm)	STK30VS-20 + SMT30VSL	230 or 460 3 PH	1,418	\$22,641	\$24,764	\$24,663

## 3 Ton Crane Kits

SMW Wire Rope Hoist & Trolley  
20' Lift, 2 Speed Lift 22/4 FPM



### How to Order

Please designate letter for electrification options at the end of the SKU.

#### Examples:

SCK-03-WR-TB20-**A** (Festoon Only)

SCK-03-WR-TB36-**B** (Traveling Pendant)

SCK-03-WR-TB60-**C** (Radio Kit)

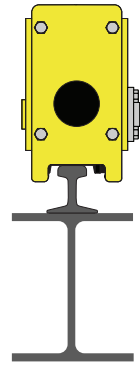

HOISTS

CRANE COMPONENTS

ELECTRIFICATION &amp; CONTROLS

CRANE KITS

SLINGS

SAFETY

SKU	Cap	Max Bridge Span (ft)	Sugg. Bridge Beam	Endtruck Model	Endtruck Wheel Tread	Hoist + Trolley Model	System Voltage	Net Weight (lbs)	List Price Options		
									A	B	C
								Festoon Only	Traveling Pendant	Radio Kit	
SCK-03-WR-TB20	3 Ton	20	W 12x40	STT-130-100-42	5.12" (130mm)	SMW0322-20	230 or 460 3 PH	1,538	\$18,235	\$19,271	\$20,173
SCK-03-WR-TB24	3 Ton	24	W 12x40	STT-130-100-42	5.12" (130mm)	SMW0322-20	230 or 460 3 PH	1,542	\$18,311	\$19,446	\$20,257
SCK-03-WR-TB28	3 Ton	28	W 14x43	STT-130-100-42	5.12" (130mm)	SMW0322-20	230 or 460 3 PH	1,546	\$18,387	\$19,620	\$20,340
SCK-03-WR-TB32	3 Ton	32	W 14x61	STT-130-100-48	5.12" (130mm)	SMW0322-20	230 or 460 3 PH	1,572	\$18,673	\$20,005	\$20,634
SCK-03-WR-TB36	3 Ton	36	W 16x67	STT-130-100-54	5.12" (130mm)	SMW0322-20	230 or 460 3 PH	1,599	\$18,959	\$20,390	\$20,928
SCK-03-WR-TB40	3 Ton	40	W 16x67	STT-130-100-60	5.12" (130mm)	SMW0322-20	230 or 460 3 PH	1,625	\$19,245	\$20,775	\$21,221
SCK-03-WR-TB44	3 Ton	44	W 18x76	STT-130-100-66	5.12" (130mm)	SMW0322-20	230 or 460 3 PH	1,652	\$19,531	\$21,159	\$21,515
SCK-03-WR-TB48	3 Ton	48	W 18x86	STT-130-100-72	5.12" (130mm)	SMW0322-20	230 or 460 3 PH	1,678	\$19,816	\$21,543	\$21,807
SCK-03-WR-TB52	3 Ton	52	W 21x101	STT-130-100-78	5.12" (130mm)	SMW0322-20	230 or 460 3 PH	1,704	\$20,102	\$21,928	\$22,101
SCK-03-WR-TB56	3 Ton	56	W 21x101	STT-130-100-84	5.12" (130mm)	SMW0322-20	230 or 460 3 PH	1,731	\$20,388	\$22,313	\$22,394
SCK-03-WR-TB60	3 Ton	60	W 21x111	STT-130-100-90	5.12" (130mm)	SMW0322-20	230 or 460 3 PH	1,757	\$20,674	\$22,697	\$22,688
SCK-03-WR-TB64	3 Ton	64	W 24x131	STT-130-100-96	5.12" (130mm)	SMW0322-20	230 or 460 3 PH	1,784	\$20,959	\$23,081	\$22,981

# 5 Ton Crane Kits

STK Electric Chain Hoist + SMT Motorized Trolley  
20' Lift, Single Speed Lift 11 FPM & 2 Speed Trolley



### How to Order

Please designate letter for electrification options at the end of the SKU.

#### Examples:

- SCK-05-EC-TB20-**A** (Festoon Only)
- SCK-05-EC-TB36-**B** (Traveling Pendant)
- SCK-05-EC-TB60-**C** (Radio Kit)

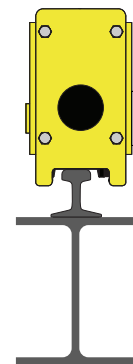

SKU	Cap	Max Bridge Span (ft)	Sugg. Bridge Beam	Endtruck Model	Endtruck Wheel Tread	Hoist + Trolley Model	System Voltage	Net Weight (lbs)	List Price Options		
									A	B	C
SCK-05-EC-TB20	5 Ton	20	W 14x48	STT-170-150-48	6.69" (170mm)	STK5011-20 + SMT50VSL	230 or 460 3 PH	1,115	\$21,781	\$22,816	\$23,719
SCK-05-EC-TB24	5 Ton	24	W 14x53	STT-170-150-48	6.69" (170mm)	STK5011-20 + SMT50VSL	230 or 460 3 PH	1,119	\$21,857	\$22,991	\$23,802
SCK-05-EC-TB28	5 Ton	28	W 14x61	STT-170-150-48	6.69" (170mm)	STK5011-20 + SMT50VSL	230 or 460 3 PH	1,123	\$21,933	\$23,166	\$23,886
SCK-05-EC-TB32	5 Ton	32	W 16x67	STT-170-150-48	6.69" (170mm)	STK5011-20 + SMT50VSL	230 or 460 3 PH	1,127	\$22,009	\$23,341	\$23,969
SCK-05-EC-TB36	5 Ton	36	W 18x76	STT-170-150-54	6.69" (170mm)	STK5011-20 + SMT50VSL	230 or 460 3 PH	1,163	\$22,253	\$23,684	\$24,221
SCK-05-EC-TB40	5 Ton	40	W 18x86	STT-170-150-60	6.69" (170mm)	STK5011-20 + SMT50VSL	230 or 460 3 PH	1,198	\$22,827	\$24,356	\$24,803
SCK-05-EC-TB44	5 Ton	44	W 21x101	STT-170-150-66	6.69" (170mm)	STK5011-20 + SMT50VSL	230 or 460 3 PH	1,234	\$23,146	\$24,774	\$25,130
SCK-05-EC-TB48	5 Ton	48	W 21x101	STT-170-150-72	6.69" (170mm)	STK5011-20 + SMT50VSL	230 or 460 3 PH	1,270	\$23,390	\$25,117	\$25,381
SCK-05-EC-TB52	5 Ton	52	W 21x111	STT-170-150-78	6.69" (170mm)	STK5011-20 + SMT50VSL	230 or 460 3 PH	1,306	\$23,633	\$25,459	\$25,632
SCK-05-EC-TB56	5 Ton	56	W 24x131	STT-170-150-84	6.69" (170mm)	STK5011-20 + SMT50VSL	230 or 460 3 PH	1,342	\$23,877	\$25,802	\$25,884
SCK-05-EC-TB60	5 Ton	60	W 27x146	STT-170-150-90	6.69" (170mm)	STK5011-20 + SMT50VSL	230 or 460 3 PH	1,378	\$24,121	\$26,144	\$26,135
SCK-05-EC-TB64	5 Ton	64	W 27x146	STT-170-150-96	6.69" (170mm)	STK5011-20 + SMT50VSL	230 or 460 3 PH	1,414	\$25,204	\$27,326	\$27,225
SCK-05-EC-TB68	5 Ton	68	Mono-Box	STT-170-150-102	6.69" (170mm)	STK5011-20 + SMT50VSL	230 or 460 3 PH	1,449	\$24,609	\$26,830	\$26,638
SCK-05-EC-TB72	5 Ton	72	Mono-Box	STT-170-150-108	6.69" (170mm)	STK5011-20 + SMT50VSL	230 or 460 3 PH	1,485	\$24,852	\$27,172	\$26,889
SCK-05-EC-TB76	5 Ton	76	Mono-Box	STT-170-150-114	6.69" (170mm)	STK5011-20 + SMT50VSL	230 or 460 3 PH	1,521	\$25,096	\$27,515	\$27,141
SCK-05-EC-TB80	5 Ton	80	Mono-Box	STT-170-150-120	6.69" (170mm)	STK5011-20 + SMT50VSL	230 or 460 3 PH	1,557	\$25,340	\$27,858	\$27,392
SCK-05-EC-TB84	5 Ton	84	Mono-Box	STT-170-150-126	6.69" (170mm)	STK5011-20 + SMT50VSL	230 or 460 3 PH	1,593	\$26,012	\$28,628	\$28,072

## 5 Ton Crane Kits

SMW Wire Rope Hoist & Trolley  
20' Lift, 2 Speed Lift 24/4 FPM



### How to Order

Please designate letter for electrification options at the end of the SKU.

#### Examples:

SCK-05-WR-TB20-**A** (Festoon Only)

SCK-05-WR-TB36-**B** (Traveling Pendant)

SCK-05-WR-TB60-**C** (Radio Kit)

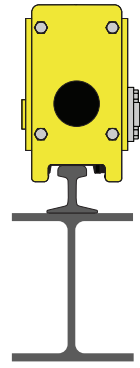

HOISTS

CRANE COMPONENTS

ELECTRIFICATION &amp; CONTROLS

CRANE KITS

SLINGS

SAFETY

SKU	Cap	Max Bridge Span (ft)	Sugg. Bridge Beam	Endtruck Model	Endtruck Wheel Tread	Hoist + Trolley Model	System Voltage	Net Weight (lbs)	List Price Options		
									A	B	C
									Festoon Only	Traveling Pendant	Radio Kit
SCK-05-WR-TB20	5 Ton	20	W 14x48	STT-170-150-48	6.69" (170mm)	SMW0524-20	230 or 460 3 PH	1,519	\$20,408	\$21,443	\$22,346
SCK-05-WR-TB24	5 Ton	24	W 14x53	STT-170-150-48	6.69" (170mm)	SMW0524-20	230 or 460 3 PH	1,523	\$20,484	\$21,618	\$22,430
SCK-05-WR-TB28	5 Ton	28	W 14x61	STT-170-150-48	6.69" (170mm)	SMW0524-20	230 or 460 3 PH	1,527	\$20,560	\$21,793	\$22,513
SCK-05-WR-TB32	5 Ton	32	W 16x67	STT-170-150-48	6.69" (170mm)	SMW0524-20	230 or 460 3 PH	1,531	\$20,636	\$21,968	\$22,597
SCK-05-WR-TB36	5 Ton	36	W 18x76	STT-170-150-54	6.69" (170mm)	SMW0524-20	230 or 460 3 PH	1,567	\$20,880	\$22,311	\$22,848
SCK-05-WR-TB40	5 Ton	40	W 18x86	STT-170-150-60	6.69" (170mm)	SMW0524-20	230 or 460 3 PH	1,602	\$21,123	\$22,653	\$23,099
SCK-05-WR-TB44	5 Ton	44	W 21x101	STT-170-150-66	6.69" (170mm)	SMW0524-20	230 or 460 3 PH	1,638	\$21,367	\$22,996	\$23,351
SCK-05-WR-TB48	5 Ton	48	W 21x101	STT-170-150-72	6.69" (170mm)	SMW0524-20	230 or 460 3 PH	1,674	\$21,612	\$23,339	\$23,603
SCK-05-WR-TB52	5 Ton	52	W 21x111	STT-170-150-78	6.69" (170mm)	SMW0524-20	230 or 460 3 PH	1,710	\$21,855	\$23,681	\$23,854
SCK-05-WR-TB56	5 Ton	56	W 24x131	STT-170-150-84	6.69" (170mm)	SMW0524-20	230 or 460 3 PH	1,746	\$22,099	\$24,024	\$24,105
SCK-05-WR-TB60	5 Ton	60	W 27x146	STT-170-150-90	6.69" (170mm)	SMW0524-20	230 or 460 3 PH	1,782	\$22,342	\$24,366	\$24,356
SCK-05-WR-TB64	5 Ton	64	W 27x146	STT-170-150-96	6.69" (170mm)	SMW0524-20	230 or 460 3 PH	1,818	\$23,425	\$25,547	\$25,447
SCK-05-WR-TB68	5 Ton	68	Mono-Box	STT-170-150-102	6.69" (170mm)	SMW0524-20	230 or 460 3 PH	1,853	\$24,988	\$27,209	\$27,017
SCK-05-WR-TB72	5 Ton	72	Mono-Box	STT-170-150-108	6.69" (170mm)	SMW0524-20	230 or 460 3 PH	1,889	\$25,231	\$27,551	\$27,268
SCK-05-WR-TB76	5 Ton	76	Mono-Box	STT-170-150-114	6.69" (170mm)	SMW0524-20	230 or 460 3 PH	1,925	\$25,475	\$27,894	\$27,520
SCK-05-WR-TB80	5 Ton	80	Mono-Box	STT-170-150-120	6.69" (170mm)	SMW0524-20	230 or 460 3 PH	1,961	\$25,719	\$28,237	\$27,771
SCK-05-WR-TB84	5 Ton	84	Mono-Box	STT-170-150-126	6.69" (170mm)	SMW0524-20	230 or 460 3 PH	1,997	\$26,391	\$29,007	\$28,451

# 5 Ton Crane Kits | Top-Running Double Girder

STW Wire Rope Hoist & Trolley  
30' Lift. 2 Speed Lift 20/4 FPM



### How to Order

Please designate letter for electrification options at the end of the SKU.

#### Examples:

SCK-05-TR-TB20-**A** (Festoon Only)

SCK-05-TR-TB36-**B** (Traveling Pendant)

SCK-05-TR-TB60-**C** (Radio Kit)

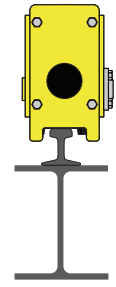

SKU	Cap	Max Bridge Span (ft)	Sugg. Bridge Beam	Endtruck Model	Trolley Gage	Hoist + Trolley Model	System Voltage	Net Weight (lbs)	List Price Options		
									A	B	C
								Festoon Only	Traveling Pendant	Radio Kit	
SCK-05-TR-TB20	5 Ton	20	W 12x26	STT-170-150-108	60"	STW0520-30	230 or 460 3 PH	2,486	\$26,454	\$27,489	\$28,392
SCK-05-TR-TB24	5 Ton	24	W 14x43	STT-170-150-108	60"	STW0520-30	230 or 460 3 PH	2,490	\$26,530	\$27,664	\$28,475
SCK-05-TR-TB28	5 Ton	28	W 14x43	STT-170-150-108	60"	STW0520-30	230 or 460 3 PH	2,494	\$26,606	\$27,839	\$28,559
SCK-05-TR-TB32	5 Ton	32	W 16x67	STT-170-150-108	60"	STW0520-30	230 or 460 3 PH	2,498	\$26,682	\$28,014	\$28,643
SCK-05-TR-TB36	5 Ton	36	W 16x67	STT-170-150-108	60"	STW0520-30	230 or 460 3 PH	2,502	\$26,758	\$28,188	\$28,726
SCK-05-TR-TB40	5 Ton	40	W 16x67	STT-170-150-108	60"	STW0520-30	230 or 460 3 PH	2,506	\$26,834	\$28,363	\$28,810
SCK-05-TR-TB44	5 Ton	44	W 18x76	STT-170-150-108	60"	STW0520-30	230 or 460 3 PH	2,510	\$26,910	\$28,538	\$28,893
SCK-05-TR-TB48	5 Ton	48	W 18x76	STT-170-150-108	60"	STW0520-30	230 or 460 3 PH	2,514	\$26,986	\$28,713	\$28,977
SCK-05-TR-TB52	5 Ton	52	W 21x101	STT-170-150-108	60"	STW0520-30	230 or 460 3 PH	2,518	\$27,062	\$28,888	\$29,061
SCK-05-TR-TB56	5 Ton	56	W 21x101	STT-170-150-108	60"	STW0520-30	230 or 460 3 PH	2,522	\$27,138	\$29,062	\$29,144
SCK-05-TR-TB60	5 Ton	60	W 21x101	STT-170-150-108	60"	STW0520-30	230 or 460 3 PH	2,526	\$27,214	\$29,237	\$29,228
SCK-05-TR-TB64	5 Ton	64	W 21x111	STT-170-150-108	60"	STW0520-30	230 or 460 3 PH	2,530	\$27,290	\$29,412	\$29,311
SCK-05-TR-TB68	5 Ton	68	34" Box 126	STT-170-150-120	60"	STW0520-30	230 or 460 3 PH	2,534	\$27,702	\$29,923	\$29,731
SCK-05-TR-TB72	5 Ton	72	36" Box 134	STT-250-150-126	60"	STW0520-30	230 or 460 3 PH	3,365	\$29,517	\$31,836	\$31,553
SCK-05-TR-TB76	5 Ton	76	38" Box 142	STT-250-150-126	60"	STW0520-30	230 or 460 3 PH	3,369	\$29,593	\$32,011	\$31,637
SCK-05-TR-TB80	5 Ton	80	40" Box 150	STT-250-150-126	60"	STW0520-30	230 or 460 3 PH	3,373	\$29,669	\$32,186	\$31,721
SCK-05-TR-TB84	5 Ton	84	43" Box 159	STT-250-150-126	60"	STW0520-30	230 or 460 3 PH	3,377	\$29,745	\$32,361	\$31,804

## 7.5 Ton Crane Kits

SMW Wire Rope Hoist & Trolley  
20' Lift, 2 Speed Lift 21/4 FPM



### How to Order

Please designate letter for electrification options at the end of the SKU.

#### Examples:

SCK-07-WR-TB20-**A** (Festoon Only)

SCK-07-WR-TB36-**B** (Traveling Pendant)

SCK-07-WR-TB60-**C** (Radio Kit)

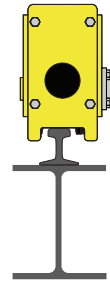

### List Price Options

SKU	Cap	Max Bridge Span (ft)	Sugg. Bridge Beam	Endtruck Model	Endtruck Wheel Tread	Hoist + Trolley Model	System Voltage	Net Weight (lbs)	List Price Options		
									A	B	C
SCK-07-WR-TB20	7.5 Ton	20	W 16x77	STT-250-150-54	9.84" (250mm)	SMW1021-20	230 or 460 3 PH	3,359	\$28,688	\$29,724	\$30,626
SCK-07-WR-TB24	7.5 Ton	24	W 16x77	STT-250-150-54	9.84" (250mm)	SMW1021-20	230 or 460 3 PH	3,363	\$28,764	\$29,898	\$30,710
SCK-07-WR-TB28	7.5 Ton	28	W 18x86	STT-250-150-54	9.84" (250mm)	SMW1021-20	230 or 460 3 PH	3,367	\$28,840	\$30,073	\$30,793
SCK-07-WR-TB32	7.5 Ton	32	W 21x101	STT-250-150-54	9.84" (250mm)	SMW1021-20	230 or 460 3 PH	3,371	\$28,916	\$30,248	\$30,877
SCK-07-WR-TB36	7.5 Ton	36	W 21x101	STT-250-150-54	9.84" (250mm)	SMW1021-20	230 or 460 3 PH	3,375	\$28,992	\$30,423	\$30,961
SCK-07-WR-TB40	7.5 Ton	40	W 21x111	STT-250-150-60	9.84" (250mm)	SMW1021-20	230 or 460 3 PH	3,428	\$29,118	\$30,648	\$31,094
SCK-07-WR-TB44	7.5 Ton	44	W 21x111	STT-250-150-60	9.84" (250mm)	SMW1021-20	230 or 460 3 PH	3,432	\$29,194	\$30,823	\$31,178
SCK-07-WR-TB48	7.5 Ton	48	W 24x131	STT-250-150-72	9.84" (250mm)	SMW1021-20	230 or 460 3 PH	3,485	\$29,321	\$31,048	\$31,312
SCK-07-WR-TB52	7.5 Ton	52	W 24x131	STT-250-150-78	9.84" (250mm)	SMW1021-20	230 or 460 3 PH	3,537	\$29,447	\$31,273	\$31,446
SCK-07-WR-TB56	7.5 Ton	56	W 24x131	STT-250-150-84	9.84" (250mm)	SMW1021-20	230 or 460 3 PH	3,590	\$29,574	\$31,499	\$31,581
SCK-07-WR-TB60	7.5 Ton	60	W 27x146	STT-250-150-90	9.84" (250mm)	SMW1021-20	230 or 460 3 PH	3,643	\$29,701	\$31,724	\$31,715
SCK-07-WR-TB64	7.5 Ton	64	Mono-Box	STT-250-150-96	9.84" (250mm)	SMW1021-20	230 or 460 3 PH	3,696	\$32,091	\$34,213	\$34,113
SCK-07-WR-TB68	7.5 Ton	68	Mono-Box	STT-250-150-102	9.84" (250mm)	SMW1021-20	230 or 460 3 PH	3,749	\$32,217	\$34,438	\$34,247
SCK-07-WR-TB72	7.5 Ton	72	Mono-Box	STT-250-150-108	9.84" (250mm)	SMW1021-20	230 or 460 3 PH	3,802	\$32,345	\$34,665	\$34,381
SCK-07-WR-TB76	7.5 Ton	76	Mono-Box	STT-250-150-114	9.84" (250mm)	SMW1021-20	230 or 460 3 PH	3,855	\$32,471	\$34,890	\$34,515
SCK-07-WR-TB80	7.5 Ton	80	Mono-Box	STT-250-150-120	9.84" (250mm)	SMW1021-20	230 or 460 3 PH	3,908	\$32,597	\$35,115	\$34,649
SCK-07-WR-TB84	7.5 Ton	84	Mono-Box	STT-250-150-126	9.84" (250mm)	SMW1021-20	230 or 460 3 PH	3,960	\$32,724	\$35,340	\$34,783
SCK-07-WR-TB88	7.5 Ton	88	Mono-Box	STT-250-150-132	9.84" (250mm)	SMW1021-20	230 or 460 3 PH	4,013	\$32,851	\$35,566	\$34,918
SCK-07-WR-TB92	7.5 Ton	92	Mono-Box	STT-250-150-138	9.84" (250mm)	SMW1021-20	230 or 460 3 PH	4,066	\$32,977	\$35,791	\$35,052
SCK-07-WR-TB96	7.5 Ton	96	Mono-Box	STT-250-150-144	9.84" (250mm)	SMW1021-20	230 or 460 3 PH	4,119	\$33,104	\$36,016	\$35,186
SCK-07-WR-TB100	7.5 Ton	100	Mono-Box	STT-250-150-150	9.84" (250mm)	SMW1021-20	230 or 460 3 PH	4,172	\$33,325	\$36,337	\$35,415

# 7.5 Ton Crane Kits | Top-Running Double Girder

STW Wire Rope Hoist & Trolley  
30' Lift, 2 Speed Lift 20/4 FPM



### How to Order

Please designate letter for electrification options at the end of the SKU.

Examples:

SCK-07-TR-TB20-A (Festoon Only)

SCK-07-TR-TB36-B (Traveling Pendant)

SCK-07-TR-TB60-C (Radio Kit)

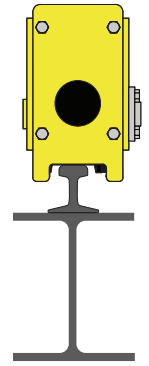

### List Price Options

SKU	Cap	Max Bridge Span (ft)	Sugg. Bridge Beam	Endtruck Model	Trolley Gage	Hoist + Trolley Model	System Voltage	Net Weight (lbs)	List Price Options		
									A	B	C
								Festoon Only	Traveling Pendant	Radio Kit	
SCK-07-TR-TB20	7.5 Ton	20	W 14x44	STT-170-150-108	60"	STW0720-30	230 or 460 3 PH	2,868	\$34,885	\$35,920	\$36,823
SCK-07-TR-TB24	7.5 Ton	24	W 14x53	STT-170-150-108	60"	STW0720-30	230 or 460 3 PH	2,872	\$34,961	\$36,095	\$36,907
SCK-07-TR-TB28	7.5 Ton	28	W 16x57	STT-170-150-108	60"	STW0720-30	230 or 460 3 PH	2,876	\$35,037	\$36,270	\$36,990
SCK-07-TR-TB32	7.5 Ton	32	W 16x57	STT-170-150-108	60"	STW0720-30	230 or 460 3 PH	2,880	\$35,113	\$36,445	\$37,074
SCK-07-TR-TB36	7.5 Ton	36	W 18x65	STT-170-150-108	60"	STW0720-30	230 or 460 3 PH	2,884	\$35,189	\$36,620	\$37,157
SCK-07-TR-TB40	7.5 Ton	40	W 18x65	STT-170-150-108	60"	STW0720-30	230 or 460 3 PH	2,888	\$35,265	\$36,794	\$37,241
SCK-07-TR-TB44	7.5 Ton	44	W 21x83	STT-170-150-108	60"	STW0720-30	230 or 460 3 PH	2,892	\$35,341	\$36,969	\$37,325
SCK-07-TR-TB48	7.5 Ton	48	W 21x83	STT-170-150-108	60"	STW0720-30	230 or 460 3 PH	2,896	\$35,417	\$37,144	\$37,408
SCK-07-TR-TB52	7.5 Ton	52	W 21x101	STT-250-150-120	60"	STW0720-30	230 or 460 3 PH	3,727	\$37,517	\$39,343	\$39,516
SCK-07-TR-TB56	7.5 Ton	56	W 24x117	STT-250-150-120	60"	STW0720-30	230 or 460 3 PH	3,731	\$37,593	\$39,518	\$39,600
SCK-07-TR-TB60	7.5 Ton	60	W 30x116	STT-250-150-120	60"	STW0720-30	230 or 460 3 PH	3,735	\$37,669	\$39,693	\$39,683
SCK-07-TR-TB64	7.5 Ton	64	32" Box 125	STT-250-150-120	60"	STW0720-30	230 or 460 3 PH	3,739	\$37,745	\$39,868	\$39,767
SCK-07-TR-TB68	7.5 Ton	68	34" Box 129	STT-250-150-120	60"	STW0720-30	230 or 460 3 PH	3,743	\$37,821	\$40,043	\$39,851
SCK-07-TR-TB72	7.5 Ton	72	36" Box 135	STT-250-150-126	60"	STW0720-30	230 or 460 / 3 PH	3747	\$37,948	\$40,268	\$39,985

# 10 Ton Crane Kits

SMW Wire Rope Hoist & Trolley  
20' Lift, 2 Speed Lift 21/4 FPM



### How to Order

Please designate letter for electrification options at the end of the SKU.

#### Examples:

SCK-10-WR-TB20-**A** (Festoon Only)

SCK-10-WR-TB36-**B** (Traveling Pendant)

SCK-10-WR-TB60-**C** (Radio Kit)

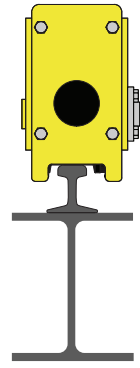

### List Price Options

A	B	C
---	---	---

SKU	Cap	Max Bridge Span (ft)	Sugg. Bridge Beam	Endtruck Model	Endtruck Wheel Tread	Hoist + Trolley Model	System Voltage	Net Weight (lbs)	List Price Options		
									Festoon Only	Traveling Pendant	Radio Kit
SCK-10-WR-TB20	10 Ton	20	W 16x89	STT-250-150-54	9.84" (250mm)	SMW1021-20	230 or 460 3 PH	3,359	\$28,688	\$29,724	\$30,626
SCK-10-WR-TB24	10 Ton	24	W 18x97	STT-250-150-54	9.84" (250mm)	SMW1021-20	230 or 460 3 PH	3,363	\$28,764	\$29,898	\$30,710
SCK-10-WR-TB28	10 Ton	28	W 24x131	STT-250-150-54	9.84" (250mm)	SMW1021-20	230 or 460 3 PH	3,367	\$28,840	\$30,073	\$30,793
SCK-10-WR-TB32	10 Ton	32	W 24x131	STT-250-150-54	9.84" (250mm)	SMW1021-20	230 or 460 3 PH	3,371	\$28,916	\$30,248	\$30,877
SCK-10-WR-TB36	10 Ton	36	W 24x131	STT-250-150-54	9.84" (250mm)	SMW1021-20	230 or 460 3 PH	3,375	\$28,992	\$30,423	\$30,961
SCK-10-WR-TB40	10 Ton	40	W 24x131	STT-250-150-60	9.84" (250mm)	SMW1021-20	230 or 460 3 PH	3,428	\$29,118	\$30,648	\$31,094
SCK-10-WR-TB44	10 Ton	44	W 27x146	STT-250-150-60	9.84" (250mm)	SMW1021-20	230 or 460 3 PH	3,432	\$29,194	\$30,823	\$31,178
SCK-10-WR-TB48	10 Ton	48	W 27x146	STT-250-150-72	9.84" (250mm)	SMW1021-20	230 or 460 3 PH	3,485	\$29,321	\$31,048	\$31,312
SCK-10-WR-TB52	10 Ton	52	W 27x161	STT-250-150-78	9.84" (250mm)	SMW1021-20	230 or 460 3 PH	3,537	\$29,447	\$31,273	\$31,446
SCK-10-WR-TB56	10 Ton	56	Mono-Box	STT-250-150-84	9.84" (250mm)	SMW1021-20	230 or 460 3 PH	3,590	\$31,838	\$33,763	33845
SCK-10-WR-TB60	10 Ton	60	Mono-Box	STT-250-150-90	9.84" (250mm)	SMW1021-20	230 or 460 3 PH	3,643	\$31,965	\$33,988	\$33,979
SCK-10-WR-TB64	10 Ton	64	Mono-Box	STT-250-150-96	9.84" (250mm)	SMW1021-20	230 or 460 3 PH	3,696	\$32,091	\$34,213	\$34,113
SCK-10-WR-TB68	10 Ton	68	Mono-Box	STT-250-150-102	9.84" (250mm)	SMW1021-20	230 or 460 3 PH	3,749	\$32,217	\$34,438	\$34,247
SCK-10-WR-TB72	10 Ton	72	Mono-Box	STT-250-150-108	9.84" (250mm)	SMW1021-20	230 or 460 3 PH	3,802	\$32,345	\$34,665	\$34,381
SCK-10-WR-TB76	10 Ton	76	Mono-Box	STT-250-150-114	9.84" (250mm)	SMW1021-20	230 or 460 3 PH	3,855	\$32,471	\$34,890	\$34,515
SCK-10-WR-TB80	10 Ton	80	Mono-Box	STT-250-150-120	9.84" (250mm)	SMW1021-20	230 or 460 3 PH	3,908	\$32,597	\$35,115	\$34,649
SCK-10-WR-TB84	10 Ton	84	Mono-Box	STT-250-150-126	9.84" (250mm)	SMW1021-20	230 or 460 3 PH	3,960	\$32,724	\$35,340	\$34,783
SCK-10-WR-TB88	10 Ton	88	Mono-Box	STT-250-150-132	9.84" (250mm)	SMW1021-20	230 or 460 3 PH	4,013	\$32,851	\$35,566	\$34,918
SCK-10-WR-TB92	10 Ton	92	Mono-Box	STT-250-150-138	9.84" (250mm)	SMW1021-20	230 or 460 3 PH	4,066	\$32,977	\$35,791	\$35,052
SCK-10-WR-TB96	10 Ton	96	Mono-Box	STT-250-150-144	9.84" (250mm)	SMW1021-20	230 or 460 3 PH	4,119	\$33,104	\$36,016	\$35,186
SCK-10-WR-TB100	10 Ton	100	Mono-Box	STT-250-150-150	9.84" (250mm)	SMW1021-20	230 or 460 3 PH	4,172	\$33,325	\$36,337	\$35,415

HOISTS

CRANE COMPONENTS

ELECTRIFICATION & CONTROLS

CRANE KITS

SLINGS

SAFETY

HOISTS

# 10 Ton Crane Kits | Top-Running Double Girder

STW Wire Rope Hoist & Trolley  
30' Lift, 2 Speed Lift 20/4 FPM

CRANE COMPONENTS



### How to Order

Please designate letter for electrification options at the end of the SKU.

#### Examples:

SCK-10-TR-TB20-**A** (Festoon Only)

SCK-10-TR-TB36-**B** (Traveling Pendant)

SCK-10-TR-TB60-**C** (Radio Kit)

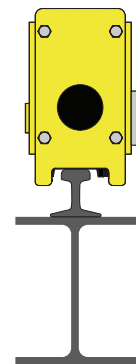

ELECTRIFICATION & CONTROLS

CRANE KITS

SLINGS

SAFETY

SKU	Cap	Max Bridge Span (ft)	Sugg. Bridge Beam	Endtruck Model	Trolley Gage	Hoist + Trolley Model	System Voltage	Net Weight (lbs)	List Price Options		
									A	B	C
									Festoon Only	Traveling Pendant	Radio Kit
SCK-10-TR-TB20	10 Ton	20	W 14x48	STT-250-150-120	60"	STW1020-30	230 or 460 3 PH	3,695	\$36,909	\$37,945	\$38,847
SCK-10-TR-TB24	10 Ton	24	W 14x61	STT-250-150-120	60"	STW1020-30	230 or 460 3 PH	3,699	\$36,985	\$38,120	\$38,931
SCK-10-TR-TB28	10 Ton	28	W 14x61	STT-250-150-120	60"	STW1020-30	230 or 460 3 PH	3,703	\$37,061	\$38,295	\$39,015
SCK-10-TR-TB32	10 Ton	32	W 16x67	STT-250-150-120	60"	STW1020-30	230 or 460 3 PH	3,707	\$37,137	\$38,469	\$39,098
SCK-10-TR-TB36	10 Ton	36	W 18x76	STT-250-150-120	60"	STW1020-30	230 or 460 3 PH	3,711	\$37,213	\$38,644	\$39,182
SCK-10-TR-TB40	10 Ton	40	W 18x76	STT-250-150-120	60"	STW1020-30	230 or 460 3 PH	3,715	\$37,289	\$38,819	\$39,265
SCK-10-TR-TB44	10 Ton	44	W 21x101	STT-250-150-120	60"	STW1020-30	230 or 460 3 PH	3,719	\$37,365	\$38,994	\$39,349
SCK-10-TR-TB48	10 Ton	48	W 21x101	STT-250-150-120	60"	STW1020-30	230 or 460 3 PH	3,723	\$37,441	\$39,169	\$39,433
SCK-10-TR-TB52	10 Ton	52	W 21x111	STT-250-150-120	60"	STW1020-30	230 or 460 3 PH	3,727	\$37,517	\$39,343	\$39,516
SCK-10-TR-TB56	10 Ton	56	W 24x131	STT-250-150-120	60"	STW1020-30	230 or 460 3 PH	3,731	\$37,593	\$39,518	\$39,600
SCK-10-TR-TB60	10 Ton	60	31" Box 135	STT-250-150-120	60"	STW1020-30	230 or 460 3 PH	3,735	\$37,669	\$39,693	\$39,683

# 15 Ton Crane Kits | Top-Running Double Girder

STW Wire Rope Hoist & Trolley

30' Lift, 2 Speed Lift 20/4 FPM



### How to Order

Please designate letter for electrification options at the end of the SKU.

#### Examples:

SCK-15-TR-TB20-**A** (Festoon Only)

SCK-15-TR-TB36-**B** (Traveling Pendant)

SCK-15-TR-TB60-**C** (Radio Kit)

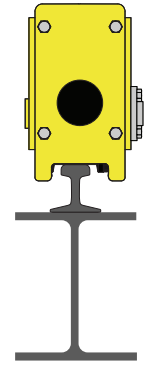

HOISTS

CRANE COMPONENTS

ELECTRIFICATION & CONTROLS

CRANE KITS

SLINGS

SAFETY

### List Price Options

SKU	Cap	Max Bridge Span (ft)	Sugg. Bridge Beam	Endtruck Model	Trolley Gage	Hoist + Trolley Model	System Voltage	Net Weight (lbs)	List Price Options		
									A	B	C
								Festoon Only	Traveling Pendant	Radio Kit	
SCK-15-TR-TB20	15 Ton	20	W 18x76	S TT-250-150-120	60"	STW1520-30	460 3 PH	4,616	\$49,046	\$50,081	\$50,984
SCK-15-TR-TB24	15 Ton	24	W 18x86	S TT-250-150-120	60"	STW1520-30	460 3 PH	4,620	\$49,122	\$50,256	\$51,067
SCK-15-TR-TB28	15 Ton	28	W 18x86	S TT-250-150-120	60"	STW1520-30	460 3 PH	4,624	\$49,198	\$50,431	\$51,151
SCK-15-TR-TB32	15 Ton	32	W 18x86	S TT-250-150-120	60"	STW1520-30	460 3 PH	4,628	\$49,274	\$50,606	\$51,234
SCK-15-TR-TB36	15 Ton	36	W 21x101	S TT-250-150-120	60"	STW1520-30	460 3 PH	4,632	\$49,350	\$50,780	\$51,318
SCK-15-TR-TB40	15 Ton	40	W 21x101	S TT-250-150-120	60"	STW1520-30	460 3 PH	4,636	\$49,426	\$50,955	\$51,402
SCK-15-TR-TB44	15 Ton	44	W 21x101	S TT-250-150-120	60"	STW1520-30	460 3 PH	4,640	\$49,502	\$51,130	\$51,485
SCK-15-TR-TB48	15 Ton	48	W 24x117	S TT-250-150-120	60"	STW1520-30	460 3 PH	4,644	\$49,578	\$51,305	\$51,569
SCK-15-TR-TB52	15 Ton	52	W 24x146	S TT-250-150-120	60"	STW1520-30	460 3 PH	4,648	\$49,654	\$51,480	\$51,652
SCK-15-TR-TB56	15 Ton	56	W 24x146	S TT-250-150-120	60"	STW1520-30	460 3 PH	4,652	\$49,730	\$51,654	\$51,736
SCK-15-TR-TB60	15 Ton	60	W 24x146	S TT-250-150-120	60"	STW1520-30	460 3 PH	4,656	\$49,806	\$51,829	\$51,820

# 15 Ton Crane Kits

SMW Wire Rope Hoist & Trolley  
20' Lift, 2 Speed Lift 21/4 FPM



### How to Order

Please designate letter for electrification options at the end of the SKU.

#### Examples:

SCK-15-WR-TB20-**A** (Festoon Only)

SCK-15-WR-TB36-**B** (Traveling Pendant)

SCK-15-WR-TB60-**C** (Radio Kit)

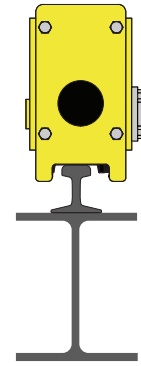

SKU	Cap	Max Bridge Span (ft)	Sugg. Bridge Beam	Endtruck Model	Endtruck Wheel Tread	Hoist + Trolley Model	System Voltage	Net Weight (lbs)	List Price Options		
									A	B	C
								Festoon Only	Traveling Pendant	Radio Kit	
SCK-15-WR-TB20	15 Ton	20	W 18x119	STT-300-200-60	11.81" (300mm)	SMW1521-20	230 or 460 3 PH	3,955	\$42,633	\$43,669	\$44,571
SCK-15-WR-TB24	15 Ton	24	W 27x146	STT-300-200-60	11.81" (300mm)	SMW1521-20	230 or 460 3 PH	3,959	\$42,709	\$43,843	\$44,655
SCK-15-WR-TB28	15 Ton	28	W 27x146	STT-300-200-60	11.81" (300mm)	SMW1521-20	230 or 460 3 PH	3,963	\$42,785	\$44,018	\$44,738
SCK-15-WR-TB32	15 Ton	32	W 27x161	STT-300-200-60	11.81" (300mm)	SMW1521-20	230 or 460 3 PH	3,967	\$42,861	\$44,193	\$44,822
SCK-15-WR-TB36	15 Ton	36	W 27x161	STT-300-200-60	11.81" (300mm)	SMW1521-20	230 or 460 3 PH	3,971	\$42,937	\$44,368	\$44,906
SCK-15-WR-TB40	15 Ton	40	W 27x161	STT-300-200-60	11.81" (300mm)	SMW1521-20	230 or 460 3 PH	3,975	\$43,013	\$44,543	\$44,989
SCK-15-WR-TB44	15 Ton	44	W 27x161	STT-300-200-66	11.81" (300mm)	SMW1521-20	230 or 460 3 PH	4,037	\$43,376	\$45,004	\$45,360
SCK-15-WR-TB48	15 Ton	48	Mono-Box	STT-300-200-78	11.81" (300mm)	SMW1521-20	230 or 460 3 PH	4,100	\$46,111	\$47,838	\$48,102
SCK-15-WR-TB52	15 Ton	52	Mono-Box	STT-300-200-78	11.81" (300mm)	SMW1521-20	230 or 460 3 PH	4,104	\$46,187	\$48,013	\$48,186
SCK-15-WR-TB56	15 Ton	56	Mono-Box	STT-300-200-78	11.81" (300mm)	SMW1521-20	230 or 460 3 PH	4,108	\$46,263	\$48,188	\$48,270
SCK-15-WR-TB60	15 Ton	60	Mono-Box	STT-300-200-90	11.81" (300mm)	SMW1521-20	230 or 460 3 PH	4,228	\$46,913	\$48,936	\$48,927
SCK-15-WR-TB64	15 Ton	64	Mono-Box	STT-300-200-96	11.81" (300mm)	SMW1521-20	230 or 460 3 PH	4,290	\$47,275	\$49,397	\$49,296
SCK-15-WR-TB68	15 Ton	68	Mono-Box	STT-300-200-102	11.81" (300mm)	SMW1521-20	230 or 460 3 PH	4,352	\$47,638	\$49,859	\$49,667
SCK-15-WR-TB72	15 Ton	72	Mono-Box	STT-300-200-108	11.81" (300mm)	SMW1521-20	230 or 460 3 PH	4,414	\$48,001	\$50,321	\$50,037
SCK-15-WR-TB76	15 Ton	76	Mono-Box	STT-300-200-114	11.81" (300mm)	SMW1521-20	230 or 460 3 PH	4,476	\$48,363	\$50,781	\$50,407
SCK-15-WR-TB80	15 Ton	80	Mono-Box	STT-300-200-120	11.81" (300mm)	SMW1521-20	230 or 460 3 PH	4,538	\$48,726	\$51,243	\$50,778

# 15 Ton Crane Kits (cont.)

## SMW Wire Rope Hoist & Trolley

### 20' Lift, 2 Speed Lift 21/4 FPM



#### How to Order

Please designate letter for electrification options at the end of the SKU.

#### Examples:

SCK-15-WR-TB20-**A** (Festoon Only)

SCK-15-WR-TB36-**B** (Traveling Pendant)

SCK-15-WR-TB60-**C** (Radio Kit)

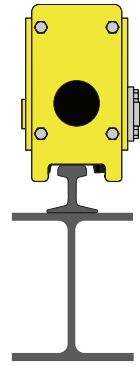

HOISTS

CRANE COMPONENTS

ELECTRIFICATION & CONTROLS

CRANE KITS

SLINGS

SAFETY

SKU	Cap	Max Bridge Span (ft)	Sugg. Bridge Beam	Endtruck Model	Endtruck Wheel Tread	Hoist + Trolley Model	System Voltage	Net Weight (lbs)	List Price Options		
									A	B	C
									Festoon Only	Traveling Pendant	Radio Kit
SCK-15-WR-TB84	15 Ton	84	Mono-Box	STT-300-200-126	11.81" (300mm)	SMW1521-20	230 or 460 3 PH	4,600	\$49,088	\$51,705	\$51,148
SCK-15-WR-TB88	15 Ton	88	Mono-Box	STT-300-200-132	11.81" (300mm)	SMW1521-20	230 or 460 3 PH	4,662	\$49,450	\$52,165	\$51,518
SCK-15-WR-TB92	15 Ton	92	Mono-Box	STT-300-200-138	11.81" (300mm)	SMW1521-20	230 or 460 3 PH	4,725	\$49,813	\$52,627	\$51,888
SCK-15-WR-TB96	15 Ton	96	Mono-Box	STT-300-200-144	11.81" (300mm)	SMW1521-20	230 or 460 3 PH	4,787	\$50,176	\$53,089	\$52,259
SCK-15-WR-TB100	15 Ton	100	Mono-Box	STT-300-200-150	11.81" (300mm)	SMW1521-20	230 or 460 3 PH	4,849	\$50,538	\$53,550	\$52,628
SCK-15-WR-TB104	15 Ton	104	Mono-Box	STT-300-200-156	11.81" (300mm)	SMW1521-20	230 or 460 3 PH	4,911	\$50,901	\$54,011	\$52,999
SCK-15-WR-TB108	15 Ton	108	Mono-Box	STT-300-200-162	11.81" (300mm)	SMW1521-20	230 or 460 3 PH	4,973	\$51,264	\$54,473	\$53,369
SCK-15-WR-TB112	15 Ton	112	Mono-Box	STT-300-200-168	11.81" (300mm)	SMW1521-20	230 or 460 3 PH	5,035	\$51,626	\$54,934	\$53,739
SCK-15-WR-TB116	15 Ton	116	Mono-Box	STT-300-200-174	11.81" (300mm)	SMW1521-20	230 or 460 3 PH	5,097	\$51,989	\$55,395	\$54,109
SCK-15-WR-TB120	15 Ton	120	Mono-Box	STT-300-200-180	11.81" (300mm)	SMW1521-20	230 or 460 3 PH	5,159	\$52,352	\$55,857	\$54,480
SCK-15-WR-TB124	15 Ton	124	Mono-Box	STT-300-200-186	11.81" (300mm)	SMW1521-20	230 or 460 3 PH	5,221	\$52,714	\$56,318	\$54,849
SCK-15-WR-TB128	15 Ton	128	Mono-Box	STT-300-200-192	11.81" (300mm)	SMW1521-20	230 or 460 3 PH	5,283	\$53,077	\$56,780	\$55,220

# 20 Ton Crane Kits | Top-Running Double Girder

STW Wire Rope Hoist & Trolley  
30' Lift, 2 Speed Lift 20/4 FPM



### How to Order

Please designate letter for electrification options at the end of the SKU.

#### Examples:

SCK-20-TR-TB20-**A** (Festoon Only)

SCK-20-TR-TB36-**B** (Traveling Pendant)

SCK-20-TR-TB60-**C** (Radio Kit)

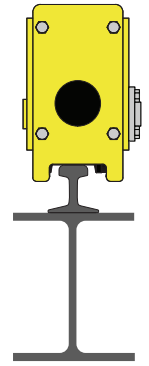

List Price Options

SKU	Cap	Max Bridge Span (ft)	Sugg. Bridge Beam	Endtruck Model	Trolley Gage	Hoist + Trolley Model	System Voltage	Net Weight (lbs)	List Price Options		
									A	B	C
								Festoon Only	Traveling Pendant	Radio Kit	
SCK-20-TR-TB20	20 Ton	20	W 18x86	STT-300-200-132	60"	STW2020-30	460 3 PH	5,192	\$56,606	\$57,641	\$58,544
SCK-20-TR-TB24	20 Ton	24	W 18x97	STT-300-200-132	60"	STW2020-30	460 3 PH	5,196	\$56,682	\$57,816	\$58,627
SCK-20-TR-TB28	20 Ton	28	W 18x97	STT-300-200-132	60"	STW2020-30	460 3 PH	5,200	\$56,758	\$57,991	\$58,711
SCK-20-TR-TB32	20 Ton	32	W 21x111	STT-300-200-132	60"	STW2020-30	460 3 PH	5,204	\$56,834	\$58,166	\$58,795
SCK-20-TR-TB36	20 Ton	36	W 21x111	STT-300-200-132	60"	STW2020-30	460 3 PH	5,208	\$56,910	\$58,340	\$58,878
SCK-20-TR-TB40	20 Ton	40	W 27x129	STT-300-200-132	60"	STW2020-30	460 3 PH	5,212	\$56,986	\$58,515	\$58,962
SCK-20-TR-TB44	20 Ton	44	W 27x129	STT-300-200-132	60"	STW2020-30	460 3 PH	5,216	\$57,062	\$58,690	\$59,045
SCK-20-TR-TB48	20 Ton	48	W 24x131	STT-300-200-132	60"	STW2020-30	460 3 PH	5,220	\$57,138	\$58,865	\$59,129
SCK-20-TR-TB52	20 Ton	52	W 24x146	STT-300-200-132	60"	STW2020-30	460 3 PH	5,224	\$57,214	\$59,040	\$59,213
SCK-20-TR-TB56	20 Ton	56	W 27x161	STT-300-200-132	60"	STW2020-30	460 3 PH	5,228	\$57,290	\$59,214	\$59,296
SCK-20-TR-TB60	20 Ton	60	32" Box 160	STT-300-200-144	60"	STW2020-30	460 3 PH	5,232	\$57,940	\$59,963	\$59,954



# TOP-RUNNER CRANE KITS

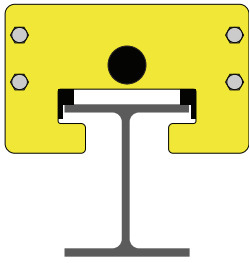

A complete crane kit that comes with the following components:

- (2) End Trucks (prime-painted gray)
- (2) Gearmotors with quick-plug adaptors
- (4) Rubber Bumpers for end trucks
- (1) VFD Bridge Control Panel with Mounting Bracket
- (1) Bridge Crane Power Feed & Endtruck Cable Kit with Quick Plug to Panel
- (2) Adjustable Bridge End Stop Kits for Hoist Travel
- (1) Short Motor Power & Control Cable
- (1) Long Motor Power & Control Cable
- (1) Runway Electrification Mount with 10' Panel Power Supply
- Zip Tie & Clamp Kit for Cable Management
- Capacity Decal Kit
- Power & Control Package Options A, B, or C



Optional Stationary Emergency Pendant Control with 17' Drop Cord & Quick-Plug to Control Panel (\$435 Add-On)

## KITS INCLUDE:

### Hoist Option



#### Electric Chain Hoists with Trolley

Standard 20' Lift. Other lift options are available.

### End Trucks

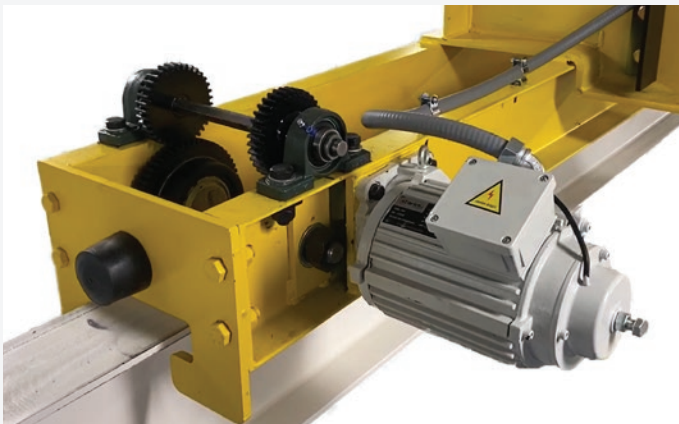

### Gear Motors

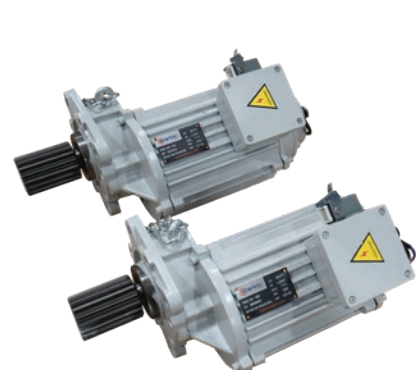

# Base Package for All Crane Kits

HOISTS

CRANE COMPONENTS

ELECTRIFICATION & CONTROLS

CRANE KITS

SLINGS

SAFETY

## VFD Control Panel with Amber Strobe Light



## Power Feed Cable



Control Panel Mounting Bracket



Quick Plug Connectors for All Cable Connections

## Motor Feed Cables



Cable Management Kit



Adjustable Bridge Crane End Stops



End Truck Bumpers

# Crane Package "A" Controls

Power & Controls Festoon Package  
(No Pendant or Radio Included)

## Festoon Package



## Power & Control Cables



## Crane Package "B" Controls

Power & Controls Festoon Package including Independent Traveling Pendant Station

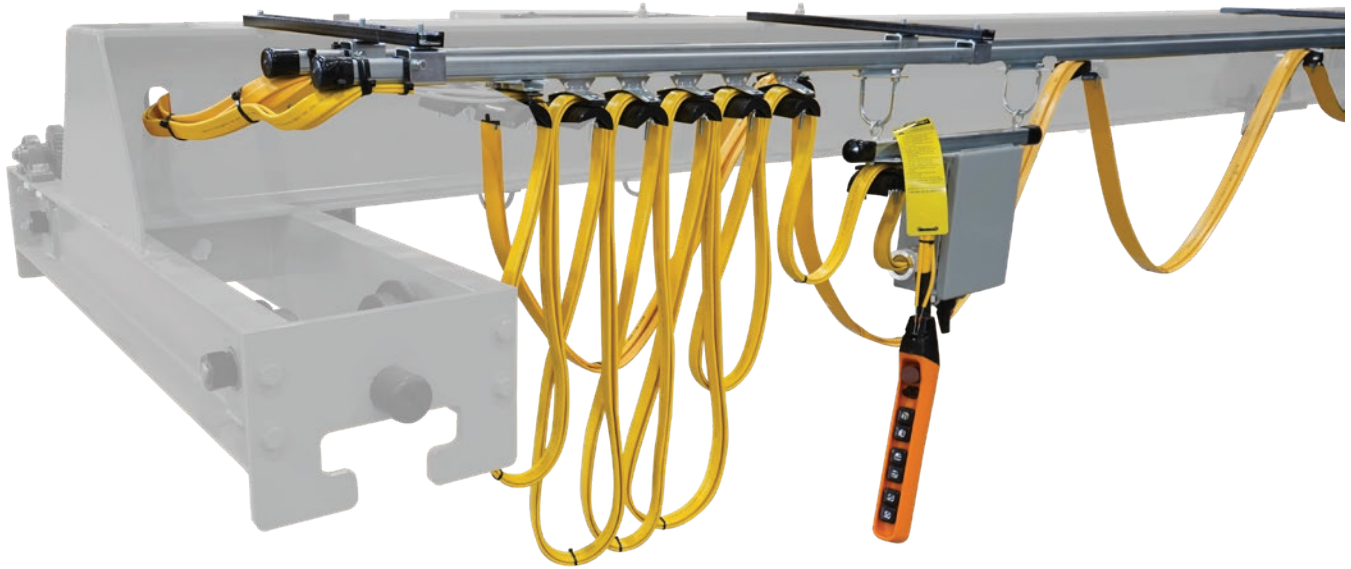

## Crane Package "C" Controls

Festoonless ElectroTrack Package + Starke Echo Series S802 Radio Control for Wireless Communication to Hoist, Trolley, and End Trucks (Includes 2 Transmitters)



# 1 Ton Crane Kits

STK Electric Chain Hoist + SMT Motorized Trolley  
20' Lift, Single Speed Lift 26 FPM & 2 Speed Trolley



### How to Order

Please designate letter for electrification options at the end of the SKU.

#### Examples:

- SCK-01-EC-TR20-**A** (Festoon Only)
- SCK-01-EC-TR36-**B** (Traveling Pendant)
- SCK-01-EC-TR60-**C** (Radio Kit)

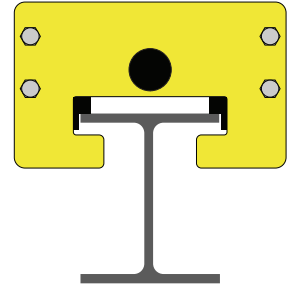

SKU	Cap	Max Bridge Span (ft)	Sugg. Bridge Beam	Endtruck Model	Endtruck Wheel Tread	Hoist + Trolley Model	System Voltage	Net Weight (lbs)	List Price Options		
									A	B	C
								Festoon Only	Traveling Pendant	Radio Kit	
SCK-01-EC-TR20	1 Ton	20	W 10x22	SCT-110-100-42	4.33" (110mm)	STK1026-20 + SMT10VSL	230 or 460 3 PH	907	\$16,410	\$17,446	\$18,348
SCK-01-EC-TR24	1 Ton	24	W 10x22	SCT-110-100-42	4.33" (110mm)	STK1026-20 + SMT10VSL	230 or 460 3 PH	911	\$16,486	\$17,621	\$18,432
SCK-01-EC-TR28	1 Ton	28	W 12x26	SCT-110-100-42	4.33" (110mm)	STK1026-20 + SMT10VSL	230 or 460 3 PH	915	\$16,562	\$17,795	\$18,516
SCK-01-EC-TR32	1 Ton	32	W 14x34	SCT-110-100-48	4.33" (110mm)	STK1026-20 + SMT10VSL	230 or 460 3 PH	936	\$16,678	\$18,010	\$18,639
SCK-01-EC-TR36	1 Ton	36	W 14x38	SCT-110-100-54	4.33" (110mm)	STK1026-20 + SMT10VSL	230 or 460 3 PH	958	\$16,794	\$18,225	\$18,763
SCK-01-EC-TR40	1 Ton	40	W 14x43	SCT-110-100-60	4.33" (110mm)	STK1026-20 + SMT10VSL	230 or 460 3 PH	979	\$16,910	\$18,440	\$18,886
SCK-01-EC-TR44	1 Ton	44	W 14x48	SCT-110-100-66	4.33" (110mm)	STK1026-20 + SMT10VSL	230 or 460 3 PH	1,002	\$17,026	\$18,654	\$19,010
SCK-01-EC-TR48	1 Ton	48	W 14x61	SCT-110-100-72	4.33" (110mm)	STK1026-20 + SMT10VSL	230 or 460 3 PH	1,074	\$17,353	\$19,080	\$19,344
SCK-01-EC-TR52	1 Ton	52	W 16x67	SCT-110-100-78	4.33" (110mm)	STK1026-20 + SMT10VSL	230 or 460 3 PH	1,099	\$17,469	\$19,295	\$19,467
SCK-01-EC-TR56	1 Ton	56	W 18x76	SCT-130-100-84	5.12" (130mm)	STK1026-20 + SMT10VSL	230 or 460 3 PH	1,124	\$19,010	\$20,934	\$21,016

## 2 Ton Crane Kits

STK Electric Chain Hoist + SMT Motorized Trolley  
20' Lift, Single Speed Lift 26 FPM & 2 Speed Trolley



### How to Order

Please designate letter for electrification options at the end of the SKU.

#### Examples:

SCK-02-EC-TR20-**A** (Festoon Only)

SCK-02-EC-TR36-**B** (Traveling Pendant)

SCK-02-EC-TR60-**C** (Radio Kit)

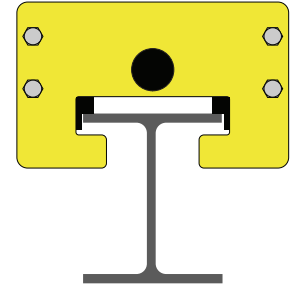

SKU	Cap	Max Bridge Span (ft)	Sugg. Bridge Beam	Endtruck Model	Endtruck Wheel Tread	Hoist + Trolley Model	System Voltage	Net Weight (lbs)	List Price Options		
									A	B	C
								Festoon Only	Traveling Pendant	Radio Kit	
SCK-02-EC-TR20	2 Ton	20	W 12x26	SCT-110-100-42	4.33" (110mm)	STK2026-20 + SMT20VSL	230 or 460 3 PH	1,046	\$17,891	\$18,927	\$19,829
SCK-02-EC-TR24	2 Ton	24	W 14x30	SCT-110-100-42	4.33" (110mm)	STK2026-20 + SMT20VSL	230 or 460 3 PH	1,050	\$17,967	\$19,102	\$19,913
SCK-02-EC-TR28	2 Ton	28	W 14x34	SCT-110-100-42	4.33" (110mm)	STK2026-20 + SMT20VSL	230 or 460 3 PH	1,054	\$18,043	\$19,276	\$19,997
SCK-02-EC-TR32	2 Ton	32	W 14x43	SCT-110-100-48	4.33" (110mm)	STK2026-20 + SMT20VSL	230 or 460 3 PH	1,075	\$18,159	\$19,491	\$20,120
SCK-02-EC-TR36	2 Ton	36	W 14x53	SCT-110-100-54	4.33" (110mm)	STK2026-20 + SMT20VSL	230 or 460 3 PH	1,097	\$18,275	\$19,706	\$20,244
SCK-02-EC-TR40	2 Ton	40	W 16x67	SCT-110-100-60	4.33" (110mm)	STK2026-20 + SMT20VSL	230 or 460 3 PH	1,118	\$18,636	\$20,166	\$20,612
SCK-02-EC-TR44	2 Ton	44	W 16x67	SCT-110-100-66	4.33" (110mm)	STK2026-20 + SMT20VSL	230 or 460 3 PH	1,141	\$18,752	\$20,380	\$20,736
SCK-02-EC-TR48	2 Ton	48	W 18x76	SCT-110-100-72	4.33" (110mm)	STK2026-20 + SMT20VSL	230 or 460 3 PH	1,213	\$18,868	\$20,595	\$20,859
SCK-02-EC-TR52	2 Ton	52	W 18x76	SCT-130-100-78	5.12" (130mm)	STK2026-20 + SMT20VSL	230 or 460 3 PH	1,443	\$20,403	\$22,229	\$22,402
SCK-02-EC-TR56	2 Ton	56	W 21x101	SCT-130-100-84	5.12" (130mm)	STK2026-20 + SMT20VSL	230 or 460 3 PH	1,476	\$20,583	\$22,508	\$22,589

### 3 Ton Crane Kits

STK Electric Chain Hoist + SMT Motorized Trolley  
20' Lift, Single Speed Lift 21 FPM & 2 Speed Trolley



**How to Order**

Please designate letter for electrification options at the end of the SKU.

Examples:

SCK-03-EC-TR20-**A** (Festoon Only)

SCK-03-EC-TR36-**B** (Traveling Pendant)

SCK-03-EC-TR60-**C** (Radio Kit)

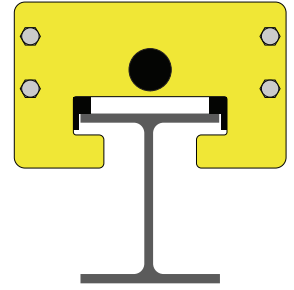

SKU	Cap	Max Bridge Span (ft)	Sugg. Bridge Beam	Endtruck Model	Endtruck Wheel Tread	Hoist + Trolley Model	System Voltage	Net Weight (lbs)	List Price Options		
									A	B	C
									Festoon Only	Traveling Pendant	Radio Kit
SCK-03-EC-TR20	3 Ton	20	W 12x40	SCT-130-100-48	5.12" (130mm)	STK3021-20 + SMT30VSL	230 or 460 3 PH	1,207	\$21,163	\$22,199	\$23,101
SCK-03-EC-TR24	3 Ton	24	W 12x40	SCT-130-100-48	5.12" (130mm)	STK3021-20 + SMT30VSL	230 or 460 3 PH	1,211	\$21,239	\$22,373	\$23,185
SCK-03-EC-TR28	3 Ton	28	W 14x43	SCT-130-100-48	5.12" (130mm)	STK3021-20 + SMT30VSL	230 or 460 3 PH	1,215	\$21,315	\$22,548	\$23,268
SCK-03-EC-TR32	3 Ton	32	W 14x61	SCT-130-100-48	5.12" (130mm)	STK3021-20 + SMT30VSL	230 or 460 3 PH	1,243	\$21,670	\$23,002	\$23,631
SCK-03-EC-TR36	3 Ton	36	W 16x67	SCT-130-100-54	5.12" (130mm)	STK3021-20 + SMT30VSL	230 or 460 3 PH	1,271	\$21,793	\$23,224	\$23,761
SCK-03-EC-TR40	3 Ton	40	W 16x67	SCT-130-100-60	5.12" (130mm)	STK3021-20 + SMT30VSL	230 or 460 3 PH	1,299	\$21,915	\$23,444	\$23,891
SCK-03-EC-TR44	3 Ton	44	W 18x76	SCT-130-100-66	5.12" (130mm)	STK3021-20 + SMT30VSL	230 or 460 3 PH	1,328	\$22,036	\$23,665	\$24,020
SCK-03-EC-TR48	3 Ton	48	W 18x86	SCT-130-100-72	5.12" (130mm)	STK3021-20 + SMT30VSL	230 or 460 3 PH	1,426	\$22,158	\$23,885	\$24,149
SCK-03-EC-TR52	3 Ton	52	W 21x101	SCT-130-100-78	5.12" (130mm)	STK3021-20 + SMT30VSL	230 or 460 3 PH	1,459	\$22,348	\$24,174	\$24,347
SCK-03-EC-TR56	3 Ton	56	W 21x101	SCT-130-100-84	5.12" (130mm)	STK3021-20 + SMT30VSL	230 or 460 3 PH	1,492	\$22,469	\$24,394	\$24,476

# Wide Flange Beam Chart

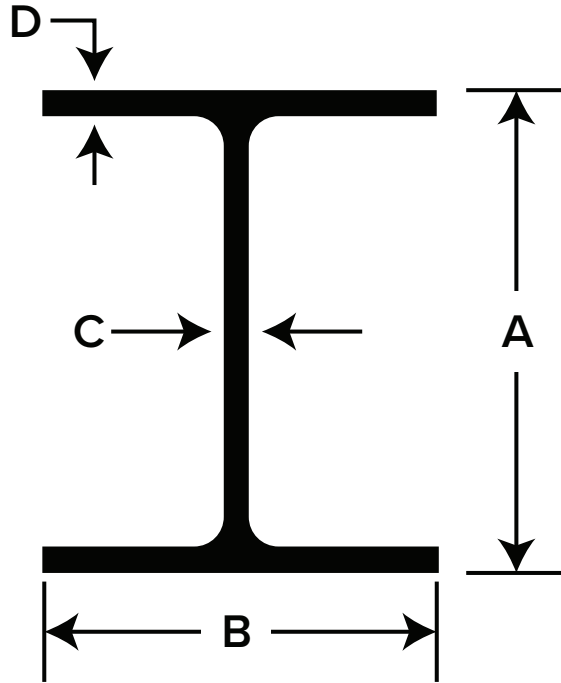

Designation	Weight (per ft)	Depth of Section (A)	Width of Flange (B)	Thickness of Web (C)	Flange Thickness (D)
W 10x22	22	10.17	5.75	0.36	0.24
W 12x26	26	12.22	6.49	0.38	0.23
W 12x40	40	11.94	8.01	0.52	0.30
W 14x30	30	13.84	6.73	0.39	0.27
W 14x34	34	13.98	6.75	0.46	0.29
W 14x38	38	14.10	6.77	0.52	0.31
W 14x43	43	13.66	8.00	0.53	0.31
W 14x48	48	13.79	8.03	0.60	0.34
W 14x53	53	13.92	8.06	0.66	0.37
W 14x61	61	13.89	10.00	0.65	0.38
W 16x67	67	16.33	10.24	0.67	0.40
W 16x77	77	16.52	10.30	0.76	0.46
W 16x89	89	16.75	10.37	0.88	0.53
W 18x76	76	18.21	11.04	0.68	0.43
W 18x86	86	18.39	11.09	0.77	0.48
W 18x97	97	18.59	11.15	0.87	0.54
W 18x119	119	18.97	11.27	1.06	1.06
W 21x101	101	21.36	12.29	0.80	0.50
W 21x111	111	21.51	12.34	0.88	0.55
W 24x131	131	24.48	12.86	0.96	0.61
W 27x146	146	27.38	13.97	0.98	0.61
W 27x161	161	27.59	14.02	1.08	0.66

# UNDER-RUNNING CRANE KITS

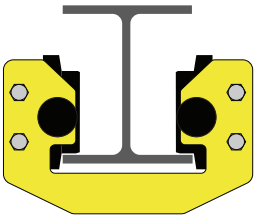

A complete crane kit that comes with the following components:

- (2) End Trucks with Girder Plates (prime-painted gray)
- (2) Gearmotors with quick-plug adaptors
- (4) Rubber Bumpers for end trucks
- (1) VFD Bridge Control Panel with Mounting Bracket
- (1) Bridge Crane Power Feed & Endtruck Cable Kit with Quick Plug to Panel
- (2) Adjustable Bridge End Stop Kits for Hoist Travel
- (1) Short Motor Power & Control Cable
- (1) Long Motor Power & Control Cable
- (1) Runway Electrification Mount with 10' Panel Power Supply
- Zip Tie & Clamp Kit for Cable Management
- Capacity Decal Kit
- Power & Control Package Options A, B, or C



Optional Stationary Emergency Pendant Control with 17' Drop Cord & Quick-Plug to Control Panel (\$435 Add-On)

## KITS INCLUDE:

### Hoist Options



#### Electric Chain Hoists with Trolley

Standard 20' Lift. Other lift options are available.

OR



#### Wire Rope Hoists

Standard 20' Lift. Other lift options are available.

### End Trucks



### Gear Motors

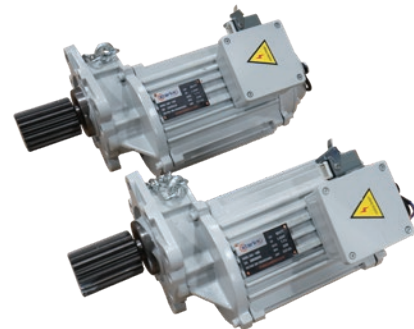

# Base Package for All Crane Kits

HOISTS  
CRANE COMPONENTS  
ELECTRIFICATION & CONTROLS  
CRANE KITS  
SLINGS  
SAFETY

### VFD Control Panel with Amber Strobe Light



### Power Feed Cable



### Control Panel Mounting Bracket



### Quick Plug Connectors for All Cable Connections

### Motor Feed Cables



### Cable Management Kit



### Adjustable Bridge Crane End Stops



### End Truck Bumpers

# Crane Package "A" Controls

Power & Controls Festoon Package  
(No Pendant or Radio Included)

## Festoon Package



## Power & Control Cables



## Crane Package "B" Controls

Power & Controls Festoon Package including Independent Traveling Pendant Station



## Crane Package "C" Controls

Festoonless ElectroTrack Package + Starke Echo Series S802 Radio Control for Wireless Communication to Hoist, Trolley, and End Trucks (Includes 2 Transmitters)



HOISTS

CRANE COMPONENTS

ELECTRIFICATION & CONTROLS

CRANE KITS

SLINGS

SAFETY

# 1 Ton Crane Kits

STK Electric Chain Hoist + SMT Motorized Trolley  
20' Lift, Single Speed Lift 26 FPM & 2 Speed Trolley

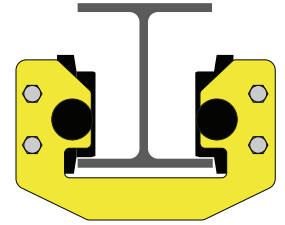

### How to Order

Please designate letter for electrification options at the end of the SKU.

#### Examples:

SCK-01-EC-UR20-**A** (Festoon Only)

SCK-01-EC-UR36-**B** (Traveling Pendant)

SCK-01-EC-UR60-**C** (Radio Kit)

SKU	Cap	Max Bridge Span (ft)	Sugg. Bridge Beam	Endtruck Model	Endtruck Wheel Tread	Hoist + Trolley Model	System Voltage	Net Weight (lbs)	List Price Options		
									A	B	C
									Festoon Only	Traveling Pendant	Radio Kit
SCK-01-EC-UR20	1 Ton	20	W 10x22	SCU-110-100-42	4.33" (110mm)	STK1026-20 + SMT10VSL	230 or 460 3 PH	907	\$16,650	\$17,685	\$18,588
SCK-01-EC-UR24	1 Ton	24	W 10x22	SCU-110-100-42	4.33" (110mm)	STK1026-20 + SMT10VSL	230 or 460 3 PH	911	\$16,726	\$17,860	\$18,671
SCK-01-EC-UR28	1 Ton	28	W 12x26	SCU-110-100-42	4.33" (110mm)	STK1026-20 + SMT10VSL	230 or 460 3 PH	915	\$16,802	\$18,035	\$18,755
SCK-01-EC-UR32	1 Ton	32	W 14x34	SCU-110-100-48	4.33" (110mm)	STK1026-20 + SMT10VSL	230 or 460 3 PH	919	\$16,918	\$18,250	\$18,878
SCK-01-EC-UR36	1 Ton	36	W 14x38	SCU-110-100-54	4.33" (110mm)	STK1026-20 + SMT10VSL	230 or 460 3 PH	940	\$17,034	\$18,464	\$19,002
SCK-01-EC-UR40	1 Ton	40	W 14x43	SCU-110-100-60	4.33" (110mm)	STK1026-20 + SMT10VSL	230 or 460 3 PH	962	\$17,149	\$18,679	\$19,125
SCK-01-EC-UR44	1 Ton	44	W 14x48	SCU-110-100-66	4.33" (110mm)	STK1026-20 + SMT10VSL	230 or 460 3 PH	983	\$17,265	\$18,894	\$19,249
SCK-01-EC-UR48	1 Ton	48	W 14x61	SCU-110-100-72	4.33" (110mm)	STK1026-20 + SMT10VSL	230 or 460 3 PH	1,006	\$17,592	\$19,319	\$19,583
SCK-01-EC-UR52	1 Ton	52	W 16x67	SCU-130-100-78	5.12" (130mm)	STK1026-20 + SMT10VSL	230 or 460 3 PH	1,078	\$18,808	\$20,634	\$20,807
SCK-01-EC-UR56	1 Ton	56	W 18x76	SCU-130-100-84	5.12" (130mm)	STK1026-20 + SMT10VSL	230 or 460 3 PH	1,103	\$18,960	\$20,885	\$20,967
SCK-01-EC-UR60	1 Ton	60	W 18x86	SCU-130-100-90	5.12" (130mm)	STK1026-20 + SMT10VSL	230 or 460 3 PH	1,128	\$19,074	\$21,098	\$21,088
SCK-01-EC-UR64	1 Ton	64	W 21x101	SCU-160-100-90	5.12" (130mm)	STK1026-20 + SMT10VSL	230 or 460 3 PH	1,153	\$20,859	\$22,981	\$22,880

## 2 Ton Crane Kits

STK Electric Chain Hoist + SMT Motorized Trolley  
20' Lift, Single Speed Lift 26 FPM & 2 Speed Trolley



### How to Order

Please designate letter for electrification options at the end of the SKU.

#### Examples:

SCK-02-EC-UR20-**A** (Festoon Only)

SCK-02-EC-UR36-**B** (Traveling Pendant)

SCK-02-EC-UR60-**C** (Radio Kit)

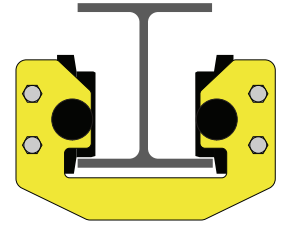

HOISTS

CRANE COMPONENTS

ELECTRIFICATION & CONTROLS

CRANE KITS

SLINGS

SAFETY

SKU	Cap	Max Bridge Span (ft)	Sugg. Bridge Beam	Endtruck Model	Endtruck Wheel Tread	Hoist + Trolley Model	System Voltage	Net Weight (lbs)	List Price Options		
									A	B	C
									Festoon Only	Traveling Pendant	Radio Kit
SCK-02-EC-UR20	2 Ton	20	W 12x26	SCU-110-100-42	4.33" (110mm)	STK2026-20 + SMT20VSL	230 or 460 3 PH	1,028	\$18,131	\$19,166	\$20,069
SCK-02-EC-UR24	2 Ton	24	W 14x30	SCU-110-100-42	4.33" (110mm)	STK2026-20 + SMT20VSL	230 or 460 3 PH	1,032	\$18,207	\$19,341	\$20,152
SCK-02-EC-UR28	2 Ton	28	W 14x34	SCU-110-100-42	4.33" (110mm)	STK2026-20 + SMT20VSL	230 or 460 3 PH	1,054	\$18,283	\$19,516	\$20,236
SCK-02-EC-UR32	2 Ton	32	W 14x43	SCU-110-100-48	4.33" (110mm)	STK2026-20 + SMT20VSL	230 or 460 3 PH	1,075	\$18,399	\$19,731	\$20,359
SCK-02-EC-UR36	2 Ton	36	W 14x53	SCU-110-100-54	4.33" (110mm)	STK2026-20 + SMT20VSL	230 or 460 3 PH	1,097	\$18,515	\$19,945	\$20,483
SCK-02-EC-UR40	2 Ton	40	W 16x67	SCU-110-100-60	4.33" (110mm)	STK2026-20 + SMT20VSL	230 or 460 3 PH	1,118	\$18,876	\$20,405	\$20,852
SCK-02-EC-UR44	2 Ton	44	W 16x67	SCU-110-100-66	4.33" (110mm)	STK2026-20 + SMT20VSL	230 or 460 3 PH	1,141	\$18,991	\$20,620	\$20,975
SCK-02-EC-UR48	2 Ton	48	W 18x76	SCU-110-100-72	4.33" (110mm)	STK2026-20 + SMT20VSL	230 or 460 3 PH	1,213	\$19,107	\$20,834	\$21,099
SCK-02-EC-UR52	2 Ton	52	W 18x76	SCU-130-100-78	5.12" (130mm)	STK2026-20 + SMT20VSL	230 or 460 3 PH	1,464	\$20,361	\$22,187	\$22,360
SCK-02-EC-UR56	2 Ton	56	W 21x101	SCU-130-100-84	5.12" (130mm)	STK2026-20 + SMT20VSL	230 or 460 3 PH	1,497	\$20,533	\$22,458	\$22,540
SCK-02-EC-UR60	2 Ton	60	W 21x101	SCU-160-100-90	6.29" (160mm)	STK2026-20 + SMT20VSL	230 or 460 3 PH	1,530	\$22,302	\$24,326	\$24,316
SCK-02-EC-UR64	2 Ton	64	W 21x111	SCU-160-100-96	6.29" (160mm)	STK2026-20 + SMT20VSL	230 or 460 3 PH	1,563	\$22,475	\$24,598	\$24,497

### 3 Ton Crane Kits

STK Electric Chain Hoist + SMT Motorized Trolley  
20' Lift, Single Speed Lift 21 FPM & 2 Speed Trolley

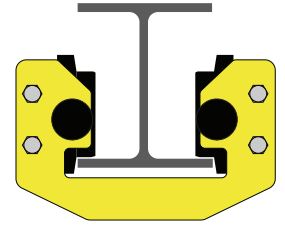

#### How to Order

Please designate letter for electrification options at the end of the SKU.

#### Examples:

SCK-03-EC-UR20-**A** (Festoon Only)

SCK-03-EC-UR36-**B** (Traveling Pendant)

SCK-03-EC-UR60-**C** (Radio Kit)

SKU	Cap	Max Bridge Span (ft)	Sugg. Bridge Beam	Endtruck Model	Endtruck Wheel Tread	Hoist + Trolley Model	System Voltage	Net Weight (lbs)	List Price Options		
									A	B	C
									Festoon Only	Traveling Pendant	Radio Kit
SCK-03-EC-UR20	3 Ton	20	W 12x40	SCU-130-100-48	5.12" (130mm)	STK3021-20 + SMT30VSL	230 or 460 3 PH	1,272	\$21,160	\$22,196	\$23,098
SCK-03-EC-UR24	3 Ton	24	W 12x40	SCU-130-100-48	5.12" (130mm)	STK3021-20 + SMT30VSL	230 or 460 3 PH	1,276	\$21,236	\$22,371	\$23,182
SCK-03-EC-UR28	3 Ton	28	W 14x43	SCU-130-100-48	5.12" (130mm)	STK3021-20 + SMT30VSL	230 or 460 3 PH	1,280	\$21,312	\$22,545	\$23,266
SCK-03-EC-UR32	3 Ton	32	W 14x61	SCU-130-100-48	5.12" (130mm)	STK3021-20 + SMT30VSL	230 or 460 3 PH	1,313	\$21,668	\$23,000	\$23,628
SCK-03-EC-UR36	3 Ton	36	W 16x67	SCU-130-100-54	5.12" (130mm)	STK3021-20 + SMT30VSL	230 or 460 3 PH	1,346	\$21,782	\$23,212	\$23,750
SCK-03-EC-UR40	3 Ton	40	W 16x67	SCU-130-100-60	5.12" (130mm)	STK3021-20 + SMT30VSL	230 or 460 3 PH	1,379	\$21,896	\$23,425	\$23,872
SCK-03-EC-UR44	3 Ton	44	W 18x76	SCU-130-100-66	5.12" (130mm)	STK3021-20 + SMT30VSL	230 or 460 3 PH	1,412	\$22,010	\$23,638	\$23,993
SCK-03-EC-UR48	3 Ton	48	W 18x86	SCU-130-100-72	5.12" (130mm)	STK3021-20 + SMT30VSL	230 or 460 3 PH	1,447	\$22,124	\$23,851	\$24,115
SCK-03-EC-UR52	3 Ton	52	W 21x101	SCU-130-100-78	5.12" (130mm)	STK3021-20 + SMT30VSL	230 or 460 3 PH	1,480	\$22,306	\$24,132	\$24,305
SCK-03-EC-UR56	3 Ton	56	W 21x101	SCU-130-100-84	5.12" (130mm)	STK3021-20 + SMT30VSL	230 or 460 3 PH	1,513	\$22,420	\$24,345	\$24,426
SCK-03-EC-UR60	3 Ton	60	W 21x111	SCU-130-100-90	5.12" (130mm)	STK3021-20 + SMT30VSL	230 or 460 3 PH	1,546	\$22,534	\$24,558	\$24,548
SCK-03-EC-UR64	3 Ton	64	W 24x131	SCU-160-100-96	6.29" (160mm)	STK3021-20 + SMT30VSL	230 or 460 3 PH	1,579	\$24,362	\$26,484	\$26,383

### 3 Ton Crane Kits

SMW Wire Rope Hoist & Trolley  
20' Lift, 2 Speed Lift 22/4 FPM & 2 Speed Trolley

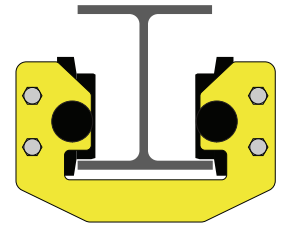

**How to Order**

Please designate letter for electrification options at the end of the SKU.

Examples:

- SCK-03-WR-UR20-**A** (Festoon Only)
- SCK-03-WR-UR36-**B** (Traveling Pendant)
- SCK-03-WR-UR60-**C** (Radio Kit)

HOISTS

CRANE COMPONENTS

ELECTRIFICATION & CONTROLS

CRANE KITS

SLINGS

SAFETY

SKU	Cap	Max Bridge Span (ft)	Sugg. Bridge Beam	Endtruck Model	Endtruck Wheel Tread	Hoist + Trolley Model	System Voltage	Net Weight (lbs)	List Price Options		
									A	B	C
SCK-03-WR-UR20	3 Ton	20	W 12x40	SCU-130-100-48	5.12" (130mm)	SMW0322-20	230 or 460 3 PH	1,652	\$20,441	\$21,477	\$22,379
SCK-03-WR-UR24	3 Ton	24	W 12x40	SCU-130-100-48	5.12" (130mm)	SMW0322-20	230 or 460 3 PH	1,656	\$20,517	\$21,651	\$22,463
SCK-03-WR-UR28	3 Ton	28	W 14x43	SCU-130-100-48	5.12" (130mm)	SMW0322-20	230 or 460 3 PH	1,660	\$20,593	\$21,826	\$22,546
SCK-03-WR-UR32	3 Ton	32	W 14x61	SCU-130-100-48	5.12" (130mm)	SMW0322-20	230 or 460 3 PH	1,693	\$20,669	\$22,001	\$22,630
SCK-03-WR-UR36	3 Ton	36	W 16x67	SCU-130-100-54	5.12" (130mm)	SMW0322-20	230 or 460 3 PH	1,726	\$20,783	\$22,214	\$22,752
SCK-03-WR-UR40	3 Ton	40	W 16x67	SCU-130-100-60	5.12" (130mm)	SMW0322-20	230 or 460 3 PH	1,759	\$20,897	\$22,427	\$22,873
SCK-03-WR-UR44	3 Ton	44	W 18x76	SCU-130-100-66	5.12" (130mm)	SMW0322-20	230 or 460 3 PH	1,792	\$21,011	\$22,639	\$22,995
SCK-03-WR-UR48	3 Ton	48	W 18x86	SCU-130-100-72	5.12" (130mm)	SMW0322-20	230 or 460 3 PH	1,827	\$21,125	\$22,852	\$23,116
SCK-03-WR-UR52	3 Ton	52	W 21x101	SCU-130-100-78	5.12" (130mm)	SMW0322-20	230 or 460 3 PH	1,860	\$21,239	\$23,065	\$23,238
SCK-03-WR-UR56	3 Ton	56	W 21x101	SCU-130-100-84	5.12" (130mm)	SMW0322-20	230 or 460 3 PH	1,893	\$21,353	\$23,278	\$23,360
SCK-03-WR-UR60	3 Ton	60	W 21x111	SCU-160-100-90	6.29" (160mm)	SMW0322-20	230 or 460 3 PH	1,926	\$23,122	\$25,146	\$25,136
SCK-03-WR-UR64	3 Ton	64	W 24x131	SCU-160-100-96	6.29" (160mm)	SMW0322-20	230 or 460 3 PH	1,959	\$23,295	\$25,417	\$25,317

## 5 Ton Crane Kits

STK Electric Chain Hoist + SMT Motorized Trolley  
20' Lift, Single Speed Lift 11 FPM & 2 Speed Trolley

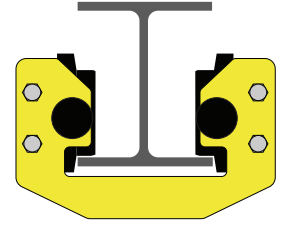

### How to Order

Please designate letter for electrification options at the end of the SKU.

#### Examples:

- SCK-05-EC-UR20-**A** (Festoon Only)
- SCK-05-EC-UR36-**B** (Traveling Pendant)
- SCK-05-EC-UR60-**C** (Radio Kit)

SKU	Cap	Max Bridge Span (ft)	Sugg. Bridge Beam	Endtruck Model	Endtruck Wheel Tread	Hoist + Trolley Model	System Voltage	Net Weight (lbs)	List Price Options		
									A	B	C
								Festoon Only	Traveling Pendant	Radio Kit	
SCK-05-EC-UR20	5 Ton	20	W 14x48	SCU-130-100-48	5.12" (130mm)	STK5011-20 + SMT50VSL	230 or 460 3 PH	1,394	\$22,384	\$23,419	\$24,322
SCK-05-EC-UR24	5 Ton	24	W 14x53	SCU-130-100-48	5.12" (130mm)	STK5011-20 + SMT50VSL	230 or 460 3 PH	1,398	\$22,460	\$23,594	\$24,406
SCK-05-EC-UR28	5 Ton	28	W 14x61	SCU-130-100-48	5.12" (130mm)	STK5011-20 + SMT50VSL	230 or 460 3 PH	1,402	\$22,536	\$23,769	\$24,489
SCK-05-EC-UR32	5 Ton	32	W 16x67	SCU-130-100-48	5.12" (130mm)	STK5011-20 + SMT50VSL	230 or 460 3 PH	1,435	\$22,612	\$23,944	\$24,573
SCK-05-EC-UR36	5 Ton	36	W 18x76	SCU-130-100-54	5.12" (130mm)	STK5011-20 + SMT50VSL	230 or 460 3 PH	1,468	\$22,726	\$24,157	\$24,694
SCK-05-EC-UR40	5 Ton	40	W 18x86	SCU-130-100-60	5.12" (130mm)	STK5011-20 + SMT50VSL	230 or 460 3 PH	1,501	\$23,171	\$24,700	\$25,147
SCK-05-EC-UR44	5 Ton	44	W 21x101	SCU-160-100-66	6.29" (160mm)	STK5011-20 + SMT50VSL	230 or 460 3 PH	2,004	\$24,782	\$26,410	\$26,765
SCK-05-EC-UR48	5 Ton	48	W 21x101	SCU-160-100-72	6.29" (160mm)	STK5011-20 + SMT50VSL	230 or 460 3 PH	2,108	\$24,955	\$26,682	\$26,946
SCK-05-EC-UR52	5 Ton	52	W 21x111	SCU-160-100-78	6.29" (160mm)	STK5011-20 + SMT50VSL	230 or 460 3 PH	2,212	\$25,127	\$26,953	\$27,126
SCK-05-EC-UR56	5 Ton	56	W 24x131	SCU-160-100-84	6.29" (160mm)	STK5011-20 + SMT50VSL	230 or 460 3 PH	2,316	\$25,299	\$27,223	\$27,305
SCK-05-EC-UR60	5 Ton	60	W 27x146	SCU-160-100-90	6.29" (160mm)	STK5011-20 + SMT50VSL	230 or 460 3 PH	2,420	\$25,471	\$27,494	\$27,485
SCK-05-EC-UR64	5 Ton	64	W 27x146	SCU-160-100-96	6.29" (160mm)	STK5011-20 + SMT50VSL	230 or 460 3 PH	2,524	\$25,644	\$27,766	\$27,665

# 5 Ton Crane Kits

SMW Wire Rope Hoist & Trolley  
20' Lift, 2 Speed Lift 24/4 FPM & 2 Speed Trolley



### How to Order

Please designate letter for electrification options at the end of the SKU.

#### Examples:

- SCK-05-WR-UR20-**A** (Festoon Only)
- SCK-05-WR-UR36-**B** (Traveling Pendant)
- SCK-05-WR-UR60-**C** (Radio Kit)

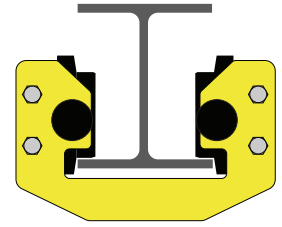

HOISTS

CRANE COMPONENTS

ELECTRIFICATION & CONTROLS

CRANE KITS

SLINGS

SAFETY

SKU	Cap	Max Bridge Span (ft)	Sugg. Bridge Beam	Endtruck Model	Endtruck Wheel Tread	Hoist + Trolley Model	System Voltage	Net Weight (lbs)	List Price Options		
									A	B	C
									Festoon Only	Traveling Pendant	Radio Kit
SCK-05-WR-UR20	5 Ton	20	W 14x48	SCU-130-100-48	5.12" (130mm)	SMW0524-20	230 or 460 3 PH	1,798	\$21,011	\$22,047	\$22,949
SCK-05-WR-UR24	5 Ton	24	W 14x53	SCU-130-100-48	5.12" (130mm)	SMW0524-20	230 or 460 3 PH	1,802	\$21,087	\$22,221	\$23,033
SCK-05-WR-UR28	5 Ton	28	W 14x61	SCU-130-100-48	5.12" (130mm)	SMW0524-20	230 or 460 3 PH	1,806	\$21,163	\$22,396	\$23,116
SCK-05-WR-UR32	5 Ton	32	W 16x67	SCU-130-100-48	5.12" (130mm)	SMW0524-20	230 or 460 3 PH	1,839	\$21,239	\$22,571	\$23,200
SCK-05-WR-UR36	5 Ton	36	W 18x76	SCU-130-100-54	5.12" (130mm)	SMW0524-20	230 or 460 3 PH	1,872	\$21,353	\$22,784	\$23,322
SCK-05-WR-UR40	5 Ton	40	W 18x86	SCU-130-100-60	5.12" (130mm)	SMW0524-20	230 or 460 3 PH	1,905	\$21,467	\$22,997	\$23,443
SCK-05-WR-UR44	5 Ton	44	W 21x101	SCU-160-100-66	6.29" (160mm)	SMW0524-20	230 or 460 3 PH	2,408	\$23,003	\$24,632	\$24,987
SCK-05-WR-UR48	5 Ton	48	W 21x101	SCU-160-100-72	6.29" (160mm)	SMW0524-20	230 or 460 3 PH	2,512	\$23,176	\$24,903	\$25,167
SCK-05-WR-UR52	5 Ton	52	W 21x111	SCU-160-100-78	6.29" (160mm)	SMW0524-20	230 or 460 3 PH	2,616	\$23,348	\$25,174	\$25,347
SCK-05-WR-UR56	5 Ton	56	W 24x131	SCU-160-100-84	6.29" (160mm)	SMW0524-20	230 or 460 3 PH	2,720	\$23,520	\$25,445	\$25,527
SCK-05-WR-UR60	5 Ton	60	W 27x146	SCU-160-100-90	6.29" (160mm)	SMW0524-20	230 or 460 3 PH	2,824	\$23,692	\$25,716	\$25,706
SCK-05-WR-UR64	5 Ton	64	W 27x146	SCU-160-100-96	6.29" (160mm)	SMW0524-20	230 or 460 3 PH	2,928	\$23,865	\$25,987	\$25,887

**7.5 Ton Crane Kits**  
 SMW Wire Rope Hoist & Trolley  
 20' Liftt, 2 Speed Lift 21/4 FPM & 2 Speed Trolley



**How to Order**

Please designate letter for electrification options at the end of the SKU.

Examples:

- SCK-07-WR-UR20-**A** (Festoon Only)
- SCK-07-WR-UR36-**B** (Traveling Pendant)
- SCK-07-WR-UR60-**C** (Radio Kit)

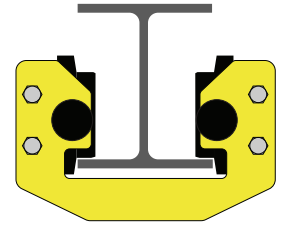

HOISTS

CRANE COMPONENTS

ELECTRIFICATION & CONTROLS

CRANE KITS

SLINGS

SAFETY

SKU	Cap	Max Bridge Span (ft)	Sugg. Bridge Beam	Endtruck Model	Endtruck Wheel Tread	Hoist + Trolley Model	System Voltage	Net Weight (lbs)	List Price Options		
									A	B	C
SCK-07-WR-UR20	7.5 Ton	20	W 16x77	SCU-160-100-54	6.29" (160mm)	SMW0721-20	230 or 460 3 PH	2,968	\$30,820	\$31,855	\$32,758
SCK-07-WR-UR24	7.5 Ton	24	W 16x77	SCU-160-100-54	6.29" (160mm)	SMW0721-20	230 or 460 3 PH	2,972	\$30,896	\$32,030	\$32,842
SCK-07-WR-UR28	7.5 Ton	28	W 18x86	SCU-160-100-54	6.29" (160mm)	SMW0721-20	230 or 460 3 PH	2,976	\$30,972	\$32,205	\$32,925
SCK-07-WR-UR32	7.5 Ton	32	W 21x101	SCU-160-100-54	6.29" (160mm)	SMW0721-20	230 or 460 3 PH	2,980	\$31,048	\$32,380	\$33,009
SCK-07-WR-UR36	7.5 Ton	36	W 21x101	SCU-160-100-54	6.29" (160mm)	SMW0721-20	230 or 460 3 PH	3,084	\$31,124	\$32,555	\$33,092
SCK-07-WR-UR40	7.5 Ton	40	W 21x111	SCU-160-100-60	6.29" (160mm)	SMW0721-20	230 or 460 3 PH	3,188	\$31,296	\$32,825	\$33,272
SCK-07-WR-UR44	7.5 Ton	44	W 21x111	SCU-160-100-66	6.29" (160mm)	SMW0721-20	230 or 460 3 PH	3,292	\$31,468	\$33,096	\$33,451
SCK-07-WR-UR48	7.5 Ton	48	W 24x131	SCU-160-100-72	6.29" (160mm)	SMW0721-20	230 or 460 3 PH	3,396	\$31,641	\$33,368	\$33,632
SCK-07-WR-UR52	7.5 Ton	52	W 24x131	SCU-160-100-78	6.29" (160mm)	SMW0721-20	230 or 460 3 PH	3,500	\$31,813	\$33,639	\$33,811
SCK-07-WR-UR56	7.5 Ton	56	W 24x131	SCU-160-100-84	6.29" (160mm)	SMW0721-20	230 or 460 3 PH	3,604	\$31,985	\$33,909	\$33,991
SCK-07-WR-UR60	7.5 Ton	60	W 27x146	SCU-190-100-90	7.48" (190mm)	SMW0721-20	230 or 460 3 PH	4,163	\$35,270	\$37,293	\$37,284
SCK-07-WR-UR64	7.5 Ton	64	Mono-Box	SCU-190-100-96	7.48" (190mm)	SMW0721-20	230 or 460 3 PH	4,237	\$35,536	\$37,658	\$37,557
SCK-07-WR-UR68	7.5 Ton	68	Mono-Box	SCU-190-100-102	7.48" (190mm)	SMW0721-20	230 or 460 3 PH	4,311	\$35,801	\$38,022	\$37,830
SCK-07-WR-UR72	7.5 Ton	72	Mono-Box	SCU-190-100-108	7.48" (190mm)	SMW0721-20	230 or 460 3 PH	4,385	\$36,067	\$38,387	\$38,104
SCK-07-WR-UR76	7.5 Ton	76	Mono-Box	SCU-190-100-114	7.48" (190mm)	SMW0721-20	230 or 460 3 PH	4,459	\$36,332	\$38,751	\$38,376
SCK-07-WR-UR80	7.5 Ton	80	Mono-Box	SCU-190-100-120	7.48" (190mm)	SMW0721-20	230 or 460 3 PH	4,533	\$36,598	\$39,115	\$38,650

# 10 Ton Crane Kits

SMW Wire Rope Hoist & Trolley  
20' Lift, 2 Speed Lift 2 1/4 FPM & 2 Speed Trolley

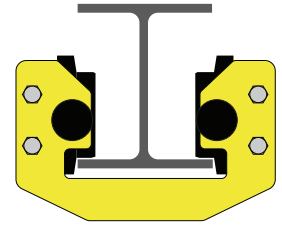

### How to Order

Please designate letter for electrification options at the end of the SKU.

#### Examples:

- SCK-10-WR-UR20-**A** (Festoon Only)
- SCK-10-WR-UR36-**B** (Traveling Pendant)
- SCK-10-WR-UR60-**C** (Radio Kit)

SKU	Cap	Max Bridge Span (ft)	Sugg. Bridge Beam	Endtruck Model	Endtruck Wheel Tread	Hoist + Trolley Model	System Voltage	Net Weight (lbs)	List Price Options		
									A	B	C
									Festoon Only	Traveling Pendant	Radio Kit
SCK-10-WR-UR20	10 Ton	20	W 16x89	SCU-160-100-54	6.29" (160mm)	SMW1021-20	230 or 460 3 PH	890	\$27,756	\$28,792	\$29,694
SCK-10-WR-UR24	10 Ton	24	W 18x97	SCU-160-100-54	6.29" (160mm)	SMW1021-20	230 or 460 3 PH	890	\$27,832	\$28,966	\$29,778
SCK-10-WR-UR28	10 Ton	28	W 24x131	SCU-160-100-54	6.29" (160mm)	SMW1021-20	230 or 460 3 PH	890	\$27,908	\$29,141	\$29,861
SCK-10-WR-UR32	10 Ton	32	W 24x131	SCU-160-100-54	6.29" (160mm)	SMW1021-20	230 or 460 3 PH	890	\$27,984	\$29,316	\$29,945
SCK-10-WR-UR36	10 Ton	36	W 24x131	SCU-160-100-54	6.29" (160mm)	SMW1021-20	230 or 460 3 PH	990	\$28,060	\$29,491	\$30,029
SCK-10-WR-UR40	10 Ton	40	W 24x131	SCU-190-100-60	7.48" (190mm)	SMW1021-20	230 or 460 3 PH	1,695	\$30,879	\$32,408	\$32,855
SCK-10-WR-UR44	10 Ton	44	W 27x146	SCU-190-100-66	7.48" (190mm)	SMW1021-20	230 or 460 3 PH	1,765	\$31,144	\$32,772	\$33,127
SCK-10-WR-UR48	10 Ton	48	W 27x146	SCU-190-100-72	7.48" (190mm)	SMW1021-20	230 or 460 3 PH	1,835	\$31,410	\$33,137	\$33,401
SCK-10-WR-UR52	10 Ton	52	W 27x161	SCU-190-100-78	7.48" (190mm)	SMW1021-20	230 or 460 3 PH	1,905	\$31,675	\$33,501	\$33,674
SCK-10-WR-UR56	10 Ton	56	Mono-Box	SCU-190-100-84	7.48" (190mm)	SMW1021-20	230 or 460 3 PH	1,975	\$31,941	\$33,866	\$33,947
SCK-10-WR-UR60	10 Ton	60	Mono-Box	SCU-190-100-90	7.48" (190mm)	SMW1021-20	230 or 460 3 PH	2,045	\$32,206	\$34,229	\$34,220
SCK-10-WR-UR64	10 Ton	64	Mono-Box	SCU-190-100-96	7.48" (190mm)	SMW1021-20	230 or 460 3 PH	2,115	\$32,472	\$34,594	\$34,494
SCK-10-WR-UR68	10 Ton	68	Mono-Box	SCU-190-100-102	7.48" (190mm)	SMW1021-20	230 or 460 3 PH	2,185	\$32,737	\$34,958	\$34,766
SCK-10-WR-UR72	10 Ton	72	Mono-Box	SCU-190-100-108	7.48" (190mm)	SMW1021-20	230 or 460 3 PH	2,255	\$33,003	\$35,323	\$35,040
SCK-10-WR-UR76	10 Ton	76	Mono-Box	SCU-190-100-114	7.48" (190mm)	SMW1021-20	230 or 460 3 PH	2,325	\$33,268	\$35,687	\$35,312
SCK-10-WR-UR80	10 Ton	80	Mono-Box	SCU-190-100-120	7.48" (190mm)	SMW1021-20	230 or 460 3 PH	2,395	\$33,534	\$36,052	\$35,586

HOISTS

CRANE COMPONENTS

ELECTRIFICATION & CONTROLS

CRANE KITS

SLINGS

SAFETY

# CHAIN SLING COMPONENTS

## 5/16" x Grade #80

SKU	Description	Working Load Limit	Weight	List
SCS-516LC	5/16 Grade #80 Chain	4,400 lbs	0.8 lbs / ft	\$3.82
SCS-58ML	5/8" Master Link (Used with 1 Leg)	6,930 lbs	1.5 lbs	\$11.61
SCS-34ML	3/4" Master Link (Used with 2 Legs)	9,350 lbs	2.1 lbs	\$15.94
SCS-10ASM	1" Master Link Assembly (Used with 3 & 4 Legs)	14,740 lbs	7 lbs	\$42.32
SCS-516HL	Hammer Lock Connector	4,400 lbs	0.4 lbs	\$8.74
SCS-516AH	Adjuster Grab Hook w/ Eye	4,400 lbs	0.7 lbs	\$7.11
SCS-516SH	Lower Sling Hook w/ Safety Latch	4,400 lbs	1.1 lbs	\$16.14
SCS-516GH	Lower Grab Hook	4,400 lbs	0.8 lbs	\$9.90
SCS-810CT	Chain ID Tag	N/A	0.2 lbs	\$5.28



## 3/8" x Grade #80

SKU	Description	Working Load Limit	Weight	List
SCS-38LC	3/8 Grade #80 Chain	6,930 lbs	1.4 lbs / ft	\$5.25
SCS-58ML	5/8" Master Link (Used with 1 Leg)	6,930 lbs	1.5 lbs	\$13.47
SCS-10ASM	1" Master Link Assembly (Used with 2 Legs)	14,740 lbs	7 lbs	\$42.32
SCS-13ASM	1 1/4" Master Link Assembly (Used with 3 & 4 Legs)	24,640 lbs	13.1 lbs	\$95.12
SCS-38HL	Hammer Lock Connector	6,930 lbs	0.7 lbs	\$9.62
SCS-38AH	Adjuster Grab Hook w/ Eye	6,930 lbs	1.6 lbs	\$14.20
SCS-38SH	Lower Sling Hook w/ Safety Latch	6,930 lbs	2.2 lbs	\$25.25
SCS-38GH	Lower Grab Hook	6,930 lbs	1.8 lbs	\$17.55
SCS-810CT	Chain ID Tag	N/A	0.2 lbs	\$5.28



w/o Adjuster Hook



Lower Sling Hook



w/Adjuster Hook



Lower Grab Hook



Chain Adjusted



ID Tag



**5/16" x Grade #100**



SKU	Description	Working Load Limit	Weight	List
SCS-516HLC	5/16 Grade #100 Chain	5,500 lbs	0.96 lbs / ft	\$5.08
SCS-58HML	5/8" Master Link (Used with 1 Leg)	7,700 lbs	1.8 lbs	\$12.95
SCS-34HML	3/4" Master Link (Used with 2 Legs)	11,000 lbs	3.3 lbs	\$21.28
SCS-10HASM	1" Master Link Assembly (Used with 3 & 4 Legs)	17,600 lbs	4.9 lbs	\$60.25
SCS-516HHL	Hammer Lock Connector	5,500 lbs	0.4 lbs	\$11.67
SCS516HAH	Adjuster Grab Hook w/ Eye	5,500 lbs	0.7 lbs	\$9.48
SCS-516HSH	Lower Sling Hook w/ Safety Latch	5,500 lbs	1.2 lbs	\$22.59
SCS-516HGH	Lower Grab Hook	5,500 lbs	0.7 lbs	\$16.20
SCS-810CT	Chain ID Tag	N/A	0.2 lbs	\$5.28

**3/8" x Grade #100**

SKU	Description	Working Load Limit	Weight	List
SCS-38HLC	3/8 Grade #100 Chain	8,800 lbs	1.53 lbs / ft	\$6.97
SCS-34HML	3/4" Master Link (Used with 1 Leg)	9,350 lbs	3.3 lbs	\$21.28
SCS-10HASM	1" Master Link Assembly (Used with 2 Legs)	17,600 lbs	4.9 lbs	\$60.25
SCS-13HASM	1 1/4" Master Link Assembly (Used with 3 & 4 Legs)	30,800 lbs	7.9 lbs	\$130.34
SCS-38HHL	Hammer Lock Connector	8,800 lbs	0.7 lbs	\$12.78
SCS38HAH	Adjuster Grab Hook w/ Eye	8,800 lbs	1.7 lbs	\$19.01
SCS-38HSH	Lower Sling Hook w/ Safety Latch	8,800 lbs	2.2 lbs	\$33.63
SCS-38HGH	Lower Grab Hook	8,800 lbs	1.8 lbs	\$23.40
SCS-810CT	Chain ID Tag	N/A	0.2 lbs	\$5.28

**ID Tag****Chain Adjusted****Lower Sling Hook****Lower Grab Hook**

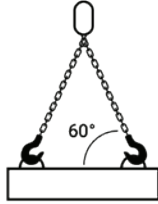
# CHAIN SLING RATING GUIDE

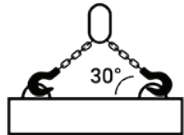
Grade #80 Capacity Chart					
Chain Size	Number of Legs	90° Angle	60° Angle	45° Angle	30° Angle
5/16"	1 Leg	4,500 lbs	N/A	N/A	N/A
	2 Leg	N/A	7,800 lbs	6,400 lbs	4,500 lbs
	3 Legs & 4 Legs	N/A	11,700 lbs	9,500 lbs	6,800 lbs
3/8"	1 Leg	7,100 lbs	N/A	N/A	N/A
	2 Leg	N/A	12,300 lbs	10,000 lbs	7,100 lbs
	3 Legs & 4 Legs	N/A	18,400 lbs	15,100 lbs	10,600 lbs

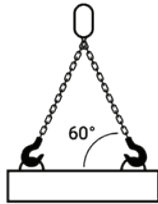
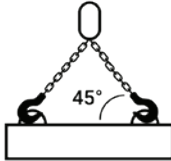
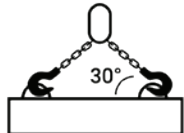
Grade #100 Capacity Chart					
Chain Size	Number of Legs	90° Angle	60° Angle	45° Angle	30° Angle
5/16"	1 Leg	5,700 lbs	N/A	N/A	N/A
	2 Leg	N/A	9,900 lbs	8,100 lbs	5,700 lbs
	3 Legs & 4 Legs	N/A	14,800 lbs	12,100 lbs	8,500 lbs
3/8"	1 Leg	8,800 lbs	N/A	N/A	N/A
	2 Leg	N/A	15,200 lbs	12,400 lbs	8,800 lbs
	3 Legs & 4 Legs	N/A	22,900 lbs	18,700 lbs	13,200 lbs

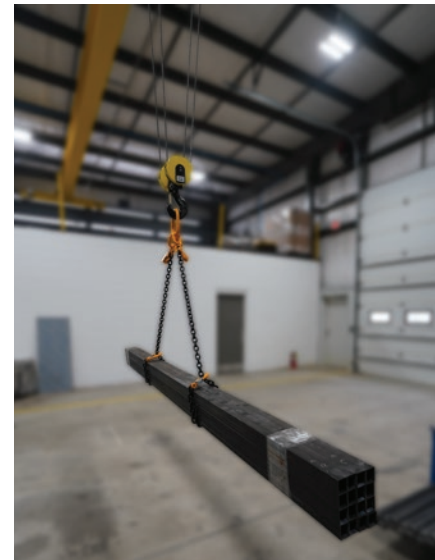
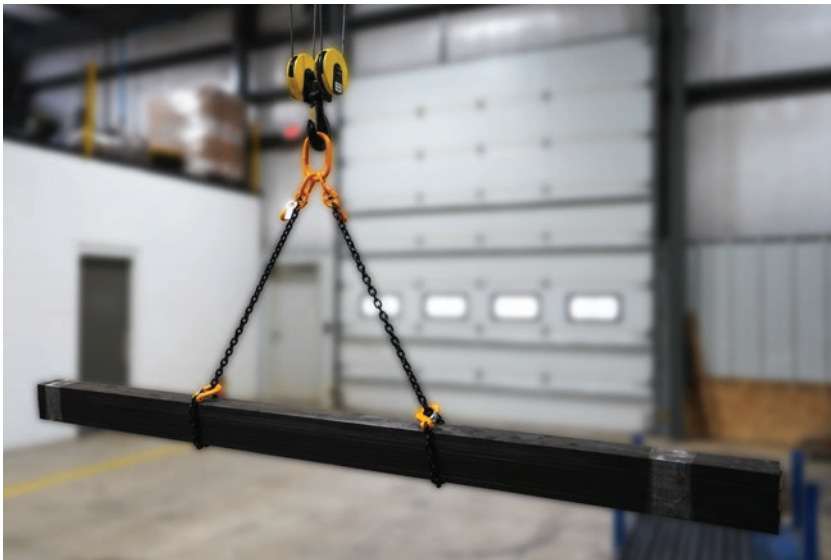

# WEB SLINGS

SKU	Length	Width	Capacity	List
SPS21E-03	3'	1"	3,100 lbs	\$17
SPS21E-04	4'	1"	3,100 lbs	\$19
SPS21E-06	6'	1"	3,100 lbs	\$22
SPS21E-08	8'	1"	3,100 lbs	\$25
SPS22E-04	4'	2"	6,200 lbs	\$27
SPS22E-06	6'	2"	6,200 lbs	\$32
SPS22E-08	8'	2"	6,200 lbs	\$37
SPS22E-10	10'	2"	6,200 lbs	\$45
SPS22E-12	12'	2"	6,200 lbs	\$49
SPS22E-16	16'	2"	6,200 lbs	\$61
SPS22E-20	20'	2"	6,200 lbs	\$73
SPS23E-08	8'	3"	8,800 lbs	\$51
SPS23E-12	12'	3"	8,800 lbs	\$70
SPS23E-16	16'	3"	8,800 lbs	\$80
SPS23E-20	20'	3"	8,800 lbs	\$106

- **Material: Polyester**
- **2 Ply**
- **Eye-to-Eye**

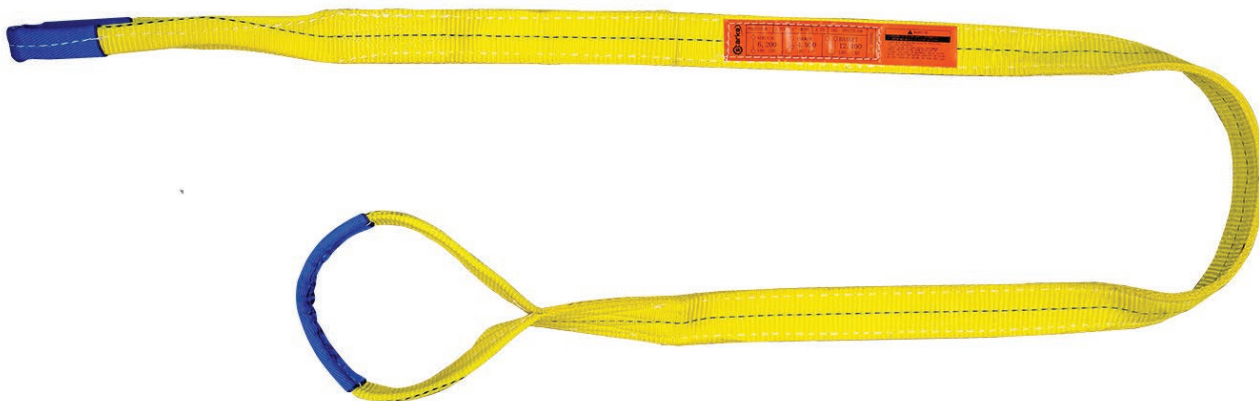
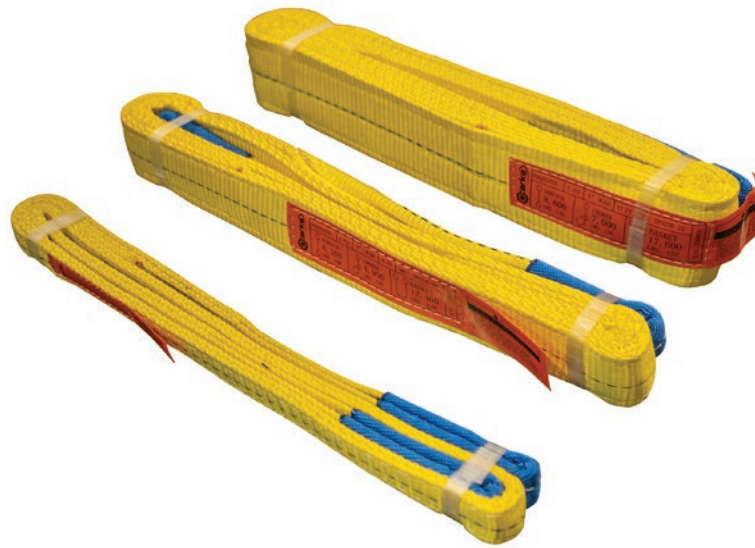
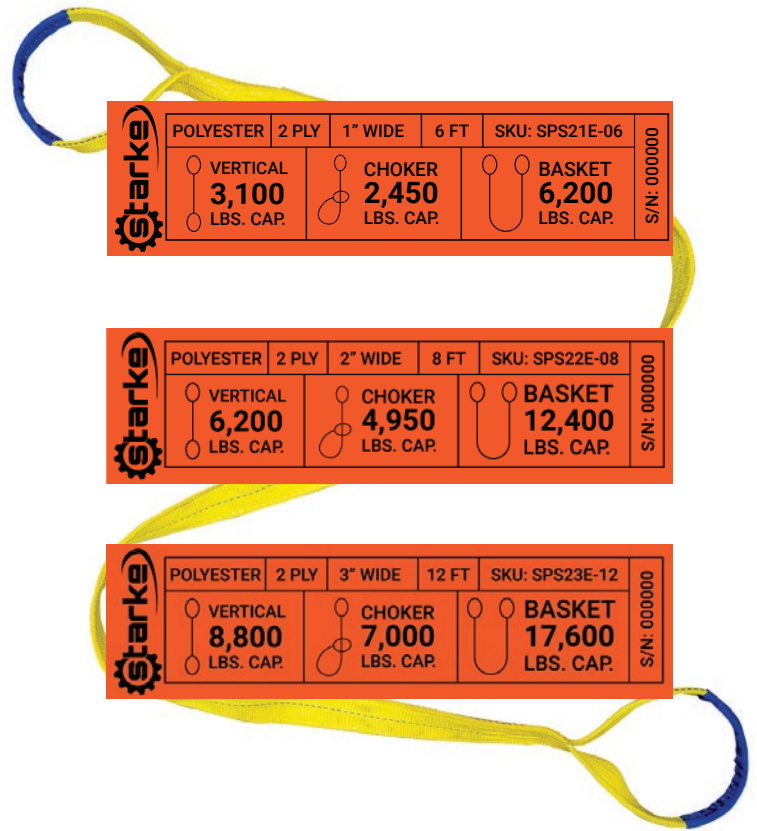

HOISTS

CRANE COMPONENTS

ELECTRIFICATION & CONTROLS

CRANE KITS

SLINGS

SAFETY

# SAFETY

## Basic Compliance Safety Harness

SKU	Size	Net Weight	List
SBC100-ML	Medium/Large	3 lbs	\$65

- Basic “one size fits all” safety harness to meet compliance for occasional use
- Includes back D-Ring and easy-to-use adjustable leg and chest straps
- Please use SDH series below for daily use or additional sizes
- Designed to meet compliance of ANSI & OSHA standards
- Weight capacity: 420 lbs



## Deluxe Safety Harness

SKU	Size	Net Weight	List
SDH200-SM	Small	3.5 lbs	\$98
SDH200-ML	Medium/Large	3.75 lbs	\$98
SDH200-XL	Extra Large	3.9 lbs	\$98
SDH200-2X	2XL	4.1 lbs	\$113
SDH200-3X	3XL	4.2 lbs	\$126

- The deluxe series harness is available in (5) sizes for a broad range of personnel
- Features Ultra-Comfort Full Shoulder & Back Padding for use the entire day
- Includes Back D-Ring and fully adjustable leg and chest straps for ultra-comfort
- Designed to meet compliance of ANSI & OSHA standards
- Weight capacity: 420 lbs





# Harness Sizing Chart

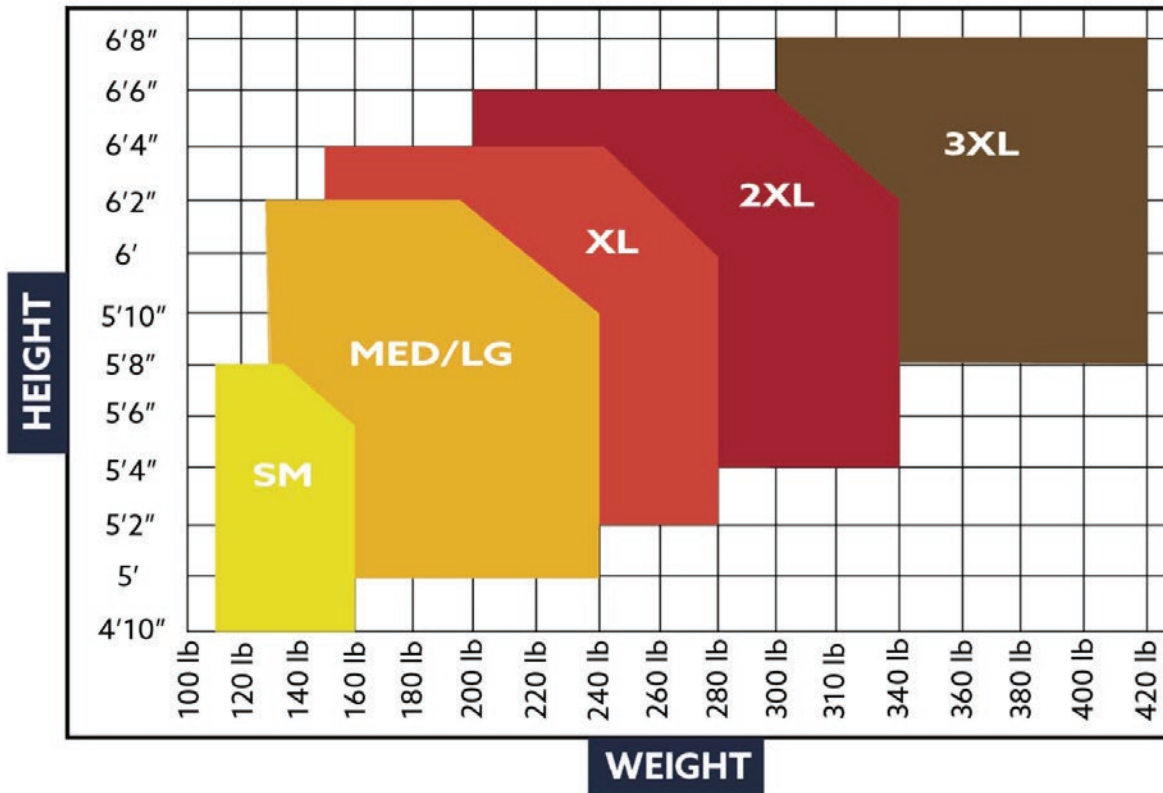

## Self-Retracting Lifelines - Steel Cable or Nylon Web Style

SKU	Length	Lower Hook	Lifeline	Net Weight	List
SRLWB-6	6'	Rebar	Poly Web	3.7 lbs	\$181
SRLWB-10	10'	Standard	Poly Web	4.8 lbs	\$192
SKU	Length	Lower Hook	Lifeline	Net Weight	List
SRLWR-20	20'	Standard	Wire Rope	9.6 lbs	\$357
SRLWR-30	30'	Standard	Wire Rope	15.5 lbs	\$533
SRLWR-50	50'	Standard	Wire Rope	20.5 lbs	\$654



## Shock-Absorbing Lanyards

SKU	Length	Absorber	Lower Hook	Net Weight	List
SALI-6	6'	Internal	LG 2" Opening	10 lbs	\$80
SALE-6	6'	External	LG 2" Opening	10 lbs	\$76



**Fall Arrest Trolley (SFT)**  
Shown on page 39



## Fall Arrest Beam Trolleys

SKU	Capacity	Description	Flange	Net Weight	List
SFT100	420 lb	Powder-Coated Light-Aluminum Construction with Nylon Wheels	3 1/2" - 8 5/8"	11 lbs	\$499
SFT200	420 lb	Zinc-Plated Carbon Steel Construction	3 1/2" - 8 5/8"	22 lbs	\$399
S300-SFT	420 lb	Fits 300 Series Track	N/A	4 lbs	\$329
S400-SFT	420 lb	Fits 400 Series Track	N/A	7 lbs	\$479

- More information about S300-SFT & S400-SFT found on page 67

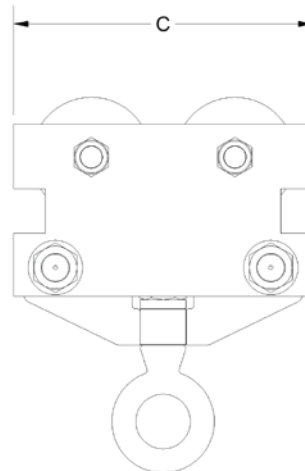
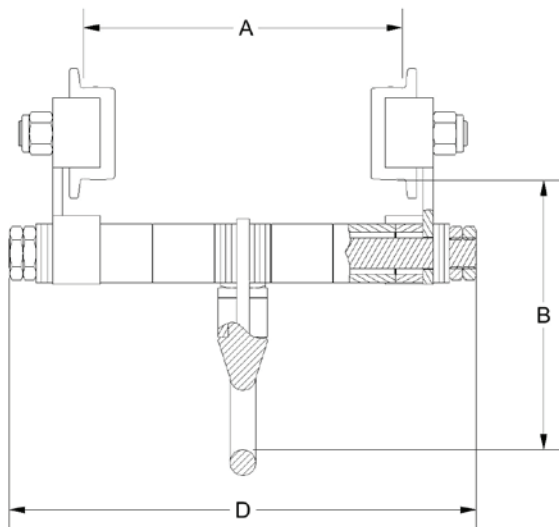

Fall Arrest Beam Trolley Dimensions				
	A	B	C	D
SFT100	3 1/2" MIN 8 5/8" MAX	6 3/4"	6 3/16"	11 7/8"
SFT200	3 1/2" MIN 8 5/8" MAX	6 3/4"	6 3/16"	11 7/8"

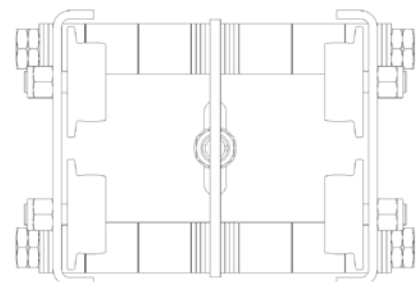

## Secondary Brake Device

SKU	Maximum Capacity	Wire Rope Specs	Net Weight	List
S2KLAS-20	2,204 lb	10.2 mm x 20'	12 lbs	\$2,469
S3KLAS-20	3,527 lb	11.5 mm x 20'	16 lbs	\$3,465

- Comes with 20' Wire Rope Kit (shown on page 131).
- Brake is applied at 100 FPM

## Secondary Brake Device with Brake Activation Sensor

SKU	Description	Maximum Capacity	Wire Rope Specs	Net Weight	List
S2KLAS-BAS-20	Brake Device with Activation Sensor, 66" Cable Assembly, and Male & Female Plug	2,204 lb	10.2 mm x 20'	13 lbs	\$2,634
S3KLAS-BAS-20	Brake Device with Activation Sensor, 66" Cable Assembly, and Male & Female Plug	3,527 lb	11.5 mm x 20'	17 lbs	\$3,630



## Brake Device Options

SKU	Description	Net Weight	List
SBD-23CW	Floor-Mounted - Wire Rope Anchor (S2 & S3 Models)	5 lbs	\$43
SBD-13CW	Counterweight Style - Wire Rope Anchor (S2 Model)	13.5 lbs	\$159
SBD-10WR	Additional 10.2mm Wire Rope	0.28 lbs / ft	\$4.19 / ft
SBD-11WR	Additional 11.5mm Wire Rope	0.34 lbs / ft	\$4.67 / ft
SBD-23BAS	Brake Activation Sensor KIT ONLY with 66" Cable Assembly and Male & Female Plug	1 lb	\$165
ST90064	Replacement Unlock Handle for S2 or S3	1 lbs	\$29



Brake Sensor Switch & Cable Assembly (BAS-20)

Male & Female Plug



S2KLAS



S3KLAS



10.2mm  
Wire Rope

20' Wire Rope  
Kit Included

**S2KLAS**



**S3KLAS**

11.5mm  
Wire Rope



Lower  
Configuration  
Options



Floor-Mounted  
Anchor

Counterweight  
Anchor

## **Starke Products Warranty 1 Year (12 Month) Parts & Labor Warranty**

Starke guarantees that our products are free from material defects in design and workmanship under normal use and proper maintenance.

This warranty is strictly limited to 12 months from the date of purchase.

Within ten days after a defect is found, warrantee must deliver a written notice to [starkeamerica.com](http://starkeamerica.com) providing defect information. All information requested by Starke warranty department must be received promptly by a Starke Master Distributor in no more than 5 business days.

Customer is responsible for all shipping charges on returned/warrantable items. Starke will cover the repair (parts and labor) at no charge or provide a replacement item at Starke's discretion.

This warranty does not cover defects or damage caused by acts of God, unusual wear and tear, improper use, or improper maintenance by the user. No responsibility for consequential damage is expressed or implied, and the responsibility under this warranty is limited to the repair or replacement of the defective materials. Repair or replacement of the item is fully at the discretion of Starke.

ALL OTHER REPRESENTATIONS, EXPRESS OR IMPLIED, WARRANTY, OR LIABILITY RELATING TO THE CONDITION OR USE OF THE PRODUCT ARE SPECIFICALLY DISAVOWED, AND IN NO EVENT SHALL STARKE BE LIABLE TO BUYER, OR ANY THIRD PARTY, FOR ANY DIRECT OR INDIRECT CONSEQUENTIAL OR INCIDENTAL DAMAGES

STARKE

[Starkeamerica.com/contact-us/](http://Starkeamerica.com/contact-us/)

## **Starke Products Service & Repair**

Should your Starke product need repair or parts replacement please direct all inquiries to [starkeamerica.com/contact-us/](http://starkeamerica.com/contact-us/) to find a distributor near you who can help with the necessary repairs or parts required.

## **Starke Product Owner Manuals**

Starke Owner's Manuals can be found online at [starkeamerica.com](http://starkeamerica.com)













**STARKEAMERICA.COM**

**DISTRIBUTOR**

A large, empty rectangular box with a thin orange border, intended for a distributor's name or contact information.